



**Installation and Operation Manual**

**GTC190 Gas Turbine Control  
for Generator Applications**

**8262-1006**

**Manual 26302**

## IMPORTANT



This is the safety alert symbol. It is used to alert you to potential personal injury hazards. Obey all safety messages that follow this symbol to avoid possible injury or death.

## DEFINITIONS

- **DANGER**—Indicates a hazardous situation which, if not avoided, will result in death or serious injury.
- **WARNING**—Indicates a hazardous situation which, if not avoided, could result in death or serious injury.
- **CAUTION**—Indicates a hazardous situation which, if not avoided, could result in minor or moderate injury.
- **NOTICE**—Indicates a hazard that could result in property damage only (including damage to the control).
- **IMPORTANT**—Designates an operating tip or maintenance suggestion.

## WARNING

The engine, turbine, or other type of prime mover should be equipped with an overspeed shutdown device to protect against runaway or damage to the prime mover with possible personal injury, loss of life, or property damage.

The overspeed shutdown device must be totally independent of the prime mover control system. An overtemperature or overpressure shutdown device may also be needed for safety, as appropriate.



Read this entire manual and all other publications pertaining to the work to be performed before installing, operating, or servicing this equipment. Practice all plant and safety instructions and precautions. Failure to follow instructions can cause personal injury and/or property damage.



This publication may have been revised or updated since this copy was produced. To verify that you have the latest revision, be sure to check the Woodward website:

[www.woodward.com/pubs/current.pdf](http://www.woodward.com/pubs/current.pdf)

The revision level is shown at the bottom of the front cover after the publication number. The latest version of most publications is available at:

[www.woodward.com/publications](http://www.woodward.com/publications)

If your publication is not there, please contact your customer service representative to get the latest copy.



Any unauthorized modifications to or use of this equipment outside its specified mechanical, electrical, or other operating limits may cause personal injury and/or property damage, including damage to the equipment. Any such unauthorized modifications: (i) constitute "misuse" and/or "negligence" within the meaning of the product warranty thereby excluding warranty coverage for any resulting damage, and (ii) invalidate product certifications or listings.

## NOTICE

To prevent damage to a control system that uses an alternator or battery-charging device, make sure the charging device is turned off before disconnecting the battery from the system.

## NOTICE

To prevent damage to electronic components caused by improper handling, read and observe the precautions in Woodward manual 82715, *Guide for Handling and Protection of Electronic Controls, Printed Circuit Boards, and Modules*.

# Contents

<b>ELECTROSTATIC DISCHARGE AWARENESS .....</b>	<b>IV</b>
<b>CHAPTER 1. GENERAL INFORMATION.....</b>	<b>1</b>
Introduction .....	1
General Description .....	2
Hardware .....	2
Software Application Program .....	5
<b>CHAPTER 2. DESCRIPTION OF OPERATION .....</b>	<b>6</b>
Introduction .....	6
Scope.....	6
Start Sequence Options .....	6
Control Loop Functions .....	8
Synchronization Logic .....	13
Load Control Options.....	13
Generator Protection .....	15
Distributed I/O Programming .....	16
Interfacing to MultiProg.....	17
Special Features of the GTC .....	17
<b>CHAPTER 3. INSTALLATION AND WIRING GUIDELINES.....</b>	<b>19</b>
Introduction .....	19
Electrical Connections .....	19
Grounding for Protection Against Electrical Shock .....	20
Input Power .....	23
<b>CHAPTER 4. POWERSENSE SIGNAL WIRING.....</b>	<b>26</b>
PowerSense Board Wiring Pinout .....	26
Potential Transformer (PT) Inputs .....	26
Current Transformer (CT) Inputs.....	34
Single Phase Monitoring.....	37
Speed Bias Output .....	37
Voltage Bias Output.....	37
LON Communication Port.....	38
<b>CHAPTER 5. CONTROL SIGNAL WIRING .....</b>	<b>41</b>
Introduction .....	41
Fuel Control Input/Output Signals .....	41
MPU (Speed) Inputs .....	41
Analog Inputs.....	43
Discrete Inputs.....	47
Discrete Outputs .....	48
Analog Outputs.....	51
Communication Ports .....	53
Software Interface Tools Setup .....	56
Configure Menu Descriptions .....	61
<b>CHAPTER 6. CONTROL FUNCTIONALITY SETUP PROCEDURES .....</b>	<b>63</b>
Introduction .....	63
Start Modes .....	63
Auto Start/Stop Sequence.....	64
Event Annunciation (Alarms/Shutdowns).....	68
Alarm Sequence .....	68
Soft Shutdown Sequence.....	69
Hard Shutdown Sequence.....	69
Setup of PT Speed Control.....	69
Setup of the Accel Control–PID or Limiter Curve .....	70

# Contents

Setup of the Decel Curve Setup .....	71
Setup of EGT Temperature Control.....	71
Setup of EGT Temp Derivative Control.....	71
Setup of Generator Settings .....	72
Setup of Load Sharing.....	72
Synchronizer.....	72
Load Control .....	73
Process Control .....	74
VAR/PF Control .....	75
Power and Energy Metering .....	75
Protective Relaying.....	75
Tunable Upload/Download Function .....	76
<b>CHAPTER 7. GENERATOR PROTECTION FUNCTIONS.....</b>	<b>77</b>
Protective Relay Descriptions.....	77
Over and Under Voltage.....	77
Over and Under Frequency .....	78
Directional Power.....	79
Negative Phase Sequence Over Voltage.....	80
Negative Phase Sequence Over Current.....	81
Phase Over Current.....	81
Directional VAR .....	82
Phase Current Imbalance.....	82
Sync Check.....	84
Voltage (VAR/PF) Bias Limit Reached .....	84
Speed / Frequency Mismatch.....	84
Inverse Time Curve .....	84
<b>CHAPTER 8. TROUBLESHOOTING .....</b>	<b>87</b>
Dynamic Response Problems .....	87
Accel/Decel Curves Setup.....	89
Poor Valve Response.....	92
Common SIO Port Configurations.....	92
Serial Null Modem Cable Reference .....	92
<b>CHAPTER 9. SERVICE OPTIONS.....</b>	<b>94</b>
Product Service Options.....	94
Woodward Factory Servicing Options .....	95
Returning Equipment for Repair.....	96
Replacement Parts .....	96
Engineering Services.....	97
How to Contact Woodward.....	97
Technical Assistance.....	98
<b>APPENDIX A. SYSTEM INPUT/OUTPUT SIGNAL LAYOUT.....</b>	<b>99</b>
<b>APPENDIX B. MODBUS LIST .....</b>	<b>116</b>
<b>APPENDIX C. ALARM/SHUTDOWN EVENT LIST .....</b>	<b>132</b>
<b>APPENDIX D. CONFIGURATION AND SERVICE TUNABLES WORKSHEET .....</b>	<b>139</b>
Configure Sheets.....	139
Service Sheets.....	142
<b>APPENDIX E. PRE-INSTALLATION CONTROL INFORMATION CHECKLIST .....</b>	<b>166</b>
<b>APPENDIX F. INTERFACING TO DISTRIBUTED IO AND MULTIPROG.....</b>	<b>167</b>

## Illustrations and Tables

Figure 2-1. GTC190 Start Sequence Logic Flow Diagram.....	7
Figure 2-2. GTC190 Functional Block Diagram .....	8
Figure 3-1. Fixed Ring Terminals .....	20
Figure 3-2. Recommended Single Point Grounding Scheme .....	21
Figure 3-3. I/O Isolation .....	22
Figure 3-4. Atlas Terminal Strip Location View .....	23
Figure 3-5. Input Power Wiring Diagram .....	24
Figure 4-1. PT Wiring—3Ø Wye, L-N, without Transformer.....	28
Figure 4-2. PT Wiring—3Ø, Wye, L-N, with Transformer.....	29
Figure 4-3. PT Wiring—3Ø Wye, L-L, with Transformers .....	30
Figure 4-4. PT Wiring—3Ø Wye, & 1Ø Wye, L-L, with Transformers.....	31
Figure 4-5. PT Wiring—3Ø Delta, L-L, with Transformers .....	32
Figure 4-6. PT Wiring—3Ø Delta, L-L, without Transformers .....	33
Figure 4-7. CT Wiring—3Ø Wye .....	35
Figure 4-8. CT Wiring—3Ø Delta .....	36
Figure 4-9. Voltage Bias Wiring Diagram, 4–20 mA Output.....	38
Figure 4-10. Voltage Bias Wiring Diagram, Bi-polar Voltage Output .....	38
Figure 4-11. LON Connections.....	39
Figure 4-12. Direct Wired LON Network.....	39
Figure 4-13. Stub Wired LON Network.....	40
Figure 5-1. MPU Wiring Diagram .....	42
Figure 5-2. Analog Input Wiring Diagram, 1–5 V.....	43
Figure 5-3. Analog Input Wiring Diagram; 4–20 mA .....	44
Figure 5-4. Discrete Output Wiring Diagram .....	49
Figure 5-5. Actuator Output Wiring Diagram .....	51
Figure 5-6. Analog Output Wiring Diagram .....	52
Figure 5-7 Serial 1 Wiring Diagrams, RS-422 .....	54
Figure 5-8 Serial 1 Wiring Diagrams, RS-485 .....	54
Figure 5-9 Serial 1 Wiring Diagrams, RS-232 .....	55
Figure 5-10. Serial 3 Wiring Diagram, RS-232.....	56
Figure 5-11. Basic Configuration Procedures .....	59
Figure 5-12. Setup ServLink Communication.....	60
Figure 5-13. Reading Control Information .....	60
Figure 5-14. Watch Window Menu and Explorer .....	61
Figure 6-1. Auto Start/Stop Sequence .....	65
Figure 7-1. Over Voltage/Under Voltage Alarm.....	78
Figure 7-2. Over Power/Reverse Power .....	79
Figure 7-3. Over Power/Reverse Power Time Delay .....	80
Figure 7-4. Phase Current Imbalance .....	83
Figure 7-5. Phase-Balance Current, Inverse Time Delay .....	83
Figure 7-6. Inverse Curve Time Delay, Level Shift .....	86
Figure 7-7. Inverse Curve Time Delay, Linear Graph .....	86
Figure 8-1. Ratio Decay Cycle .....	88
Figure 8-2. Proportional Gain Settings.....	89
Figure 8-3. Linearized Flow Schedule.....	91
Table 1-1. AtlasPC Input/Output List.....	4
Table 1-2. Distributed Input/Output List.....	4
Table 8-1. Valve Test Data.....	91
Table 8-2. Valve Test Data.....	92

## Electrostatic Discharge Awareness

All electronic equipment is static-sensitive, some components more than others. To protect these components from static damage, you must take special precautions to minimize or eliminate electrostatic discharges.

Follow these precautions when working with or near the control.

1. Before doing maintenance on the electronic control, discharge the static electricity on your body to ground by touching and holding a grounded metal object (pipes, cabinets, equipment, etc.).
2. Avoid the build-up of static electricity on your body by not wearing clothing made of synthetic materials. Wear cotton or cotton-blend materials as much as possible because these do not store static electric charges as much as synthetics.
3. Keep plastic, vinyl, and Styrofoam materials (such as plastic or Styrofoam cups, cup holders, cigarette packages, cellophane wrappers, vinyl books or folders, plastic bottles, and plastic ash trays) away from the control, the modules, and the work area as much as possible.
4. Do not remove the printed circuit board (PCB) from the control cabinet unless absolutely necessary. If you must remove the PCB from the control cabinet, follow these precautions:
  - Do not touch any part of the PCB except the edges.
  - Do not touch the electrical conductors, the connectors, or the components with conductive devices or with your hands.
  - When replacing a PCB, keep the new PCB in the plastic antistatic protective bag it comes in until you are ready to install it. Immediately after removing the old PCB from the control cabinet, place it in the antistatic protective bag.

### **NOTICE**

To prevent damage to electronic components caused by improper handling, read and observe the precautions in Woodward manual 82715, *Guide for Handling and Protection of Electronic Controls, Printed Circuit Boards, and Modules*.

# Chapter 1.

## General Information

### Introduction

This manual describes the GTC190 Digital Control System designed to control single-shaft gas turbines for generator applications. It is pre-programmed to perform fuel metering control, a minimal start/stop sequencing routine and communications to a package OI (Operator Interface) or plant DCS (Distributed Control System). The control has a runtime license for the ProConOS operating systems and the application has been designed to integrate with a user created MultiProg (MP) program. The application also has been pre-programmed to access a large amount of Distributed I/O that can be used to handle all of the ancillary equipment and plant signals that are needed to control the entire turbine/generator package. This manual should be used along with the standard AtlasPC™ hardware manual (85586 Vol 1 & 2), and therefore the scope of this document is only to describe details of the GTC190 application software functionality and assist the customer in configuration and start-up of the control. Refer to manuals 85586 for information on hardware specifications, mounting information, and wiring details.

- The **GTC190** performs the functions described above. It is intended for applications on single-shaft turbines applied on power generation packages.

### Scope of Supply

Item #	Description
8262-1006	GTC190 AtlasPC w/ PSENS, Profibus and DeviceNet (Single Shaft Gas Turbine Fuel Control)
BCD85216	CD—GTC190 System Documentation & Software Tools

### Optional Add-ons

Item #	Description
1784-505	Moore Industries AD590 Ambient Temperature Signal Converter
8900-067	Ambient Air Temperature Sensor (AD590)
5441-699	Relay Interface (12) FTM
5417-747	Relay FTM Interface Cable
8200-224	Servo Position Controller (SPC) – up to Quantity of 4
Inquire	GS Valves
Inquire	Distributed I/O Kit

## General Description

The Woodward GTC190 AtlasPC Digital Control System is a configurable control system for industrial gas turbines that produces a fuel demand output to control speed, load, pressure, and temperature. It contains optional start/stop sequence control and Modbus® \* communication links (Local & Remote) to an optional HMI or a user defined operator interface. The GTC190 also includes an I/O module that interfaces to Generator and Utility bus PT's and CT's performing functions such as synchronization, power metering, breaker commands and load sharing. In addition to this, the control has a runtime license to allow the customer to create their own program using MultiProg. With this tool they can customize the use of this control for a specific site. For a given GTC model, the maximum I/O available is fixed (both AtlasPC direct and distributed I/O) and has been pre-programmed into the unit. If additional I/O is required, the customer should inquire about other models of the GTC family.

\*—Modbus is a trademark of Schneider Automation Inc.

## Hardware

The GTC190 AtlasPC Digital Control is designed to be bulkhead mounted in a control panel. The complete unit contains a 'SmartCore' module, a Pentium CPU module, a Power Supply board, a PowerSense module, 2 Analog Combo modules, a DeviceNet interface port (for fuel valves & SPC drivers) and a Profibus interface port for distributed I/O. In addition, the system can also include an optional relay Field Termination Module (FTM). These components are designed for DIN rail mounting in the control cabinet.

The CPU module controls the system. The I/O modules interface the CPU module to the outside world, permitting it to sense digital and analog inputs and to issue analog and discrete outputs.

### Power Requirements

The AtlasPC Digital Control System requires an 18-32 Vdc input supply voltage.

### Physical Description

For further details on the physical hardware, signal accuracy or environmental specifications, refer to the AtlasPC product manual 85586 (Vol 1 & 2).

## Central Processor Unit (CPU) Module

The Pentium CPU runs under a VxWorks® \* real time operating system and follows the instructions of the application program, which controls all of the Input and Output circuits of the GTC190 AtlasPC Control.

\*—VxWorks is a trademark of Wind River Systems, Inc.

The CPU module has the following Communications Ports:

### Ethernet 100BT—

10/100 Base-TX Ethernet port used for Modbus communication and service tools.

### OS Service Port—

This port is a dedicated operating system debug port and should not be used.



**Profibus–**

This is the port connection that links to the Distributed I/O.

**DeviceNet–**

This is the port connection that links to the Fuel Valves and Servo Position Controllers.

**SmartCore Module**

The SmartCore module has the following Communications Ports:

**Serial COM 1**

The COM 1 Serial Port is configured for use as a Modbus interface on this control.

**Serial COM 2**

The COM 2 Serial Port is configured for use as a Modbus interface on this control.

**Serial COM 3**

This port is RS232 only and is a dedicated as a ServLink Port that interfaces to the Woodward software interface tools.

**I/O Modules**

Each module has a FAULT LED that is controlled by the CPU. During every initialization of the system, the CPU turns these LEDs on. The CPU then individually tests each I/O module. If an I/O module fails any test, the FAULT LED remains on. The FAULT LED remaining on after the diagnostics have run may mean that the module has failed a test.

If the FAULT LED's come on at any other time one of 3 things has occurred:

1. The module has faulted
2. The CPU / Operating System has detected a fault and shutdown the module
3. The unit has been placed in IO Lock by the Watch Window service tool (which happens when the unit is placed in Configure mode).

For further details on the specific hardware modules installed in this system refer to the AtlasPC product manual 85586.

**GTC190 CORE AtlasPC I/O** - The direct local I/O (input/output) is:

Type of Input	# of Inputs	Options/Details
<b>DC Power Input</b>		
Low Voltage dc input	1	18–32 Vdc, protected from reverse polarity
<b>Analog Inputs</b>		
Function Configurable Inputs	16	Current 4-20 mA dc or Voltage 0-5 Vdc
Thermocouple Inputs	20	T/C type configurable
MPU Speed Sensor	6	100–20 000 Hz
Bus PT Input	1	3-phase ac input
Generator PT Input	1	3-phase ac input
Bus CT Input	1	3-phase ac input
Generator CT Input	1	3-phase ac input
<b>Analog Outputs</b>		
Configurable Analog (Speed Bias)	1	±3 Vdc, 1–5 Vdc, 500 Hz, PWM, 4–20 mA
Voltage Bias	1	±1 Vdc, ±3 Vdc, ±9 Vdc, 4–20 mA
Function Configurable outputs	10	Current (4-20 mA)
Proportional Actuator outputs	2	Current 0-20 mA or 0-200mA range
<b>Discrete Inputs</b>		
Configurable Switch or Contact inputs	24	Switch to + to activate, Isolated from input power
<b>Discrete Outputs</b>		
Relay Driver Outputs	12	Low side drivers
<b>Communication Ports</b>		
DeviceNet Port	6	<b>Fuel Driver Interfaces (GS's &amp; SPC's)</b>
Serial Ports	3	(1)—RS-232, (2)—RS-232/422/485

Table 1-1. AtlasPC Input/Output List

**GTC190 Distributed I/O** - The pre-programmed AB Flex (1794- series) I/O is:

Type of Input	# of Inputs	Options/Details
<b>Profibus Communication Head</b>	<b>4</b>	DISTRIBUTED I/O -PROFIBUS ADAPTER – Either 1794-PDP OR ProSoft 3170-PDP ( <b>NOTE: These require different Applicom configuration files to the I/O modules</b> ) - Equip Head #1 = 5 DI - Equip Head #2 = 6 T/C, 2 RTD - Equip Head #3 = 5 AI, 2 AO - Equip Head #4 = 4 DO
<b>Analog Inputs</b>		
Analog Current Inputs	40	MODULE-ANALOG INPUT, ALLEN-BRADLEY (1794-IE8/B)
Thermocouple Inputs	48	MODULE -TC INPUT, ALLEN-BRADLEY (1794-IT8)
RTD Inputs	16	RTD INPUT, ALLEN-BRADLEY (1794-IR8)
<b>Analog Outputs</b>		
Analog Current Outputs	8	MODULE-ANALOG OUTPUT, ALLEN-BRADLEY (1794-OE4/B)
<b>Discrete Inputs</b>		
Contact inputs	160	MODULE-DISCRETE INPUT, ALLEN-BRADLEY (1794-IB32)
<b>Discrete Outputs</b>		
Relay Driver Outputs	128	DISCRETE OUTPUT, ALLEN-BRADLEY (1794-OB32P)

Table 1-2. Distributed Input/Output List

## Software Application Program

The application program is designed by using the Woodward GAP™ Graphical Application Program. The GAP program, which runs on a standard PC (personal computer), builds and compiles the application program file. This application code is then processed through a coder/compiler, which generates the application program code. This executable code is then loaded into memory on the CPU module circuit board. The GTC190 application is designed as a fuel control for a single-shaft gas turbine and is intended to provide proper fuel demand control from the initial 'Fuel On' signal to 'Fuel Off'. The GTC190 control, as delivered from Woodward, also contains software options to provide turbine start/stop sequencing logic. It contains configurable start permissives and can control the turbine motor starter, ignitors, and positive fuel shutoff valves (block valves) in addition to the fuel-metering valve for both Gas and Liquid fuels. The GTC190 takes PT and CT inputs directly into the PowerSense module, which allows the application to include functionality of monitoring of the generator and Bus power, synchronization, breaker closure, reactive load control and load sharing. The application also allows the user to take some of the GTC programmed I/O signals and reallocate them for a site specific use for some off-turbine package sub-system indication, or plant process requirements. Specifics on the options available for customer signals are in the fuel control Input / Output signal section. All of the pre-programmed distributed I/O is intended to be available for customer programming via the Multiprog IEC61131-3 compliant software programming tool.

In summary the GTC190 can be configured to provide complete automated control of a gas turbine from start to light off, to rated speed, synchronization, breaker closure and ramp up to full load setpoint. The user also has the capability to add any specific programming by use of the Multiprog tool.



**A separate and independent overspeed trip device is always required to be installed to prevent possible serious injury from an overspeeding prime mover.**

# Chapter 2.

## Description of Operation

### Introduction

This chapter describes the operation and features included in the GTC190 system for control of a gas turbine driving a generator. The purpose of the chapter is to provide a clear understanding of the functions and features that are available in this Woodward GTC product.

### Scope

The control has been divided into major functions for this description. Many of these functions have sub-functions, and all of these may not be utilized in your specific unit. The major functions of this AtlasPC™ Digital Control System include:

- Start Sequence Options
- Control Loop Functions
- Synchronization Logic
- Load Control Options
- Generator Protection
- Distributed I/O Programming
- Interfacing to MultiProg

### Start Sequence Options

The sections below will provide insight as to the options programmed into the GTC for starting the gas turbine. The functional block diagram Figure 2.1 will provide an overview of the startup sequence, the specific details of setting up the start options for each sequence step is found in Chapter 6.

- Configurable Start/Stop Sequencing Logic
- Turbine Lite-Off and Flameout Detection
- Start Ramp and Start Control Logic
- Optional EGT start temp limiter

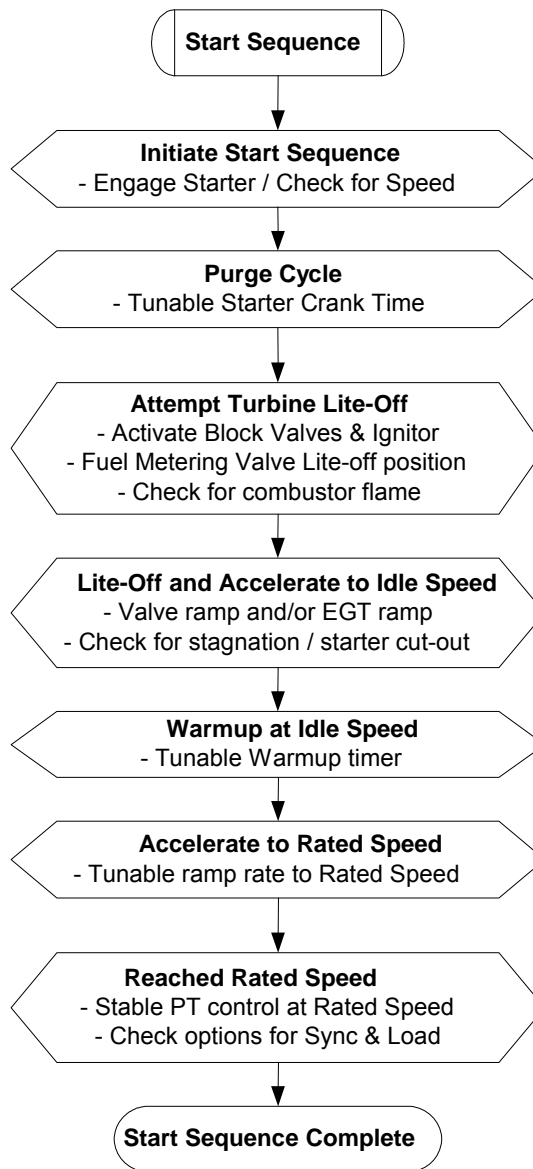

Figure 2-1. GTC190 Start Sequence Logic Flow Diagram

### Start Sequence Logic

The control contains options for Starting the unit up to rated speed, closing the breaker and auto-loading the unit. Details of this logic can be found in Chapter 6.

## Control Loop Functions

The sections below will provide insight as to how the control application software implements the functions shown in the functional block diagram of Figure 2.2.

- Ambient Temperature Sensing
- Single Shaft Speed Sensing (w/ Redundant probes, up to 4)
- Turbine Inlet Temperature Sensing
- Compressor Discharge Pressure (CDP or PCD) Sensing
- Exhaust Gas Temperature (EGT) Sensing (1-18 T/C inputs)
- Shaft Speed Reference Logic
- Remote Speed Reference Logic
- Speed Control of Power Turbine Shaft (PT)
- Speed Derivative (Acceleration) Control
- Load Control of Power Turbine
- EGT Limiting Control
- EGT Derivative Control
- Megawatt Limiting Control
- Process Control
- Fuel Actuator Demand and Fuel Transfer Logic

## Functional Block Diagram

The following diagram shows a general outline of the functionality of the GTC190 control.

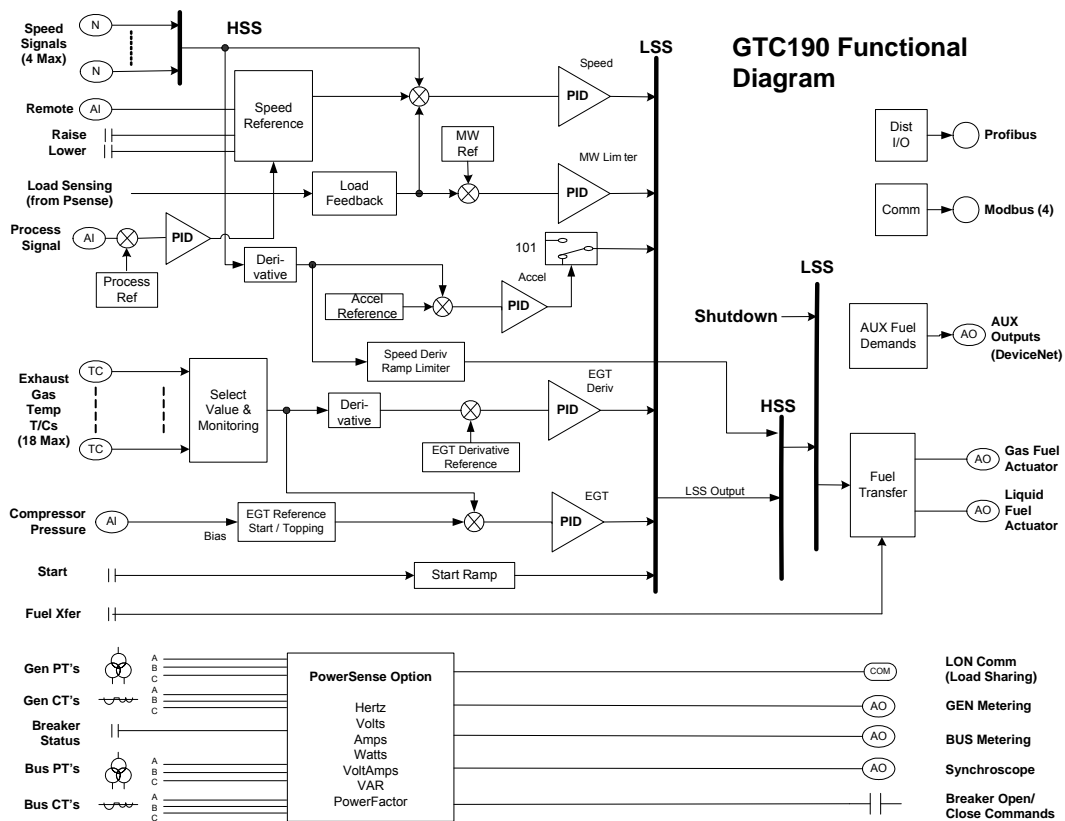

Figure 2-2. GTC190 Functional Block Diagram

## Speed Control of the Turbine Shaft (SPD) PID

The intent of this controller is to maintain desired speed and load of the turbine shaft. Under normal operating conditions, the unit will be loaded while in this mode and maintain speed control from zero load to maximum load. The Speed control PID compares the actual speed signal with the speed reference and calculates an appropriate output response. The Speed control PID has three inputs:

- Actual speed input from the speed probes
- Speed reference input
- Feedback input from the LSS

The speed reference setpoint can also be driven by a generic Process Control PID that is cascaded into the speed reference logic. A user can utilize this feature to have the speed reference (turbine load) determined by the closed loop control of some plant specific process input.

The GTC190 CORE application also contains some handles to allow the user to perform overspeed tests (if that is a requirement). It will allow the user to temporarily bias the overpseed trip level that is programmed in Configure mode and permit the speed reference to be raised above its normal maximum value. The intent is to allow the testing of any external trip device that is set outside of the GTC190 trip level.

## Speed Derivative / ACCEL Control (SPD\_DERIV) PID or Curve

The speed derivative PID controls the maximum amount of fuel delivered based on the shaft acceleration speed. The setpoint is a limiting speed rate of change (rpm/sec) and the process variable monitored is the derivative of the speed shaft.

The acceleration curve schedule method determines the maximum amount of fuel allowed, during acceleration. This demand is driven by a configurable curve based on CDP. The CDP versus Fuel Demand accel limit curve will determine the maximum amount of fuel allowed for the current CDP.

This fuel demand limiter feeds into the LSS bus. If this value is the lowest on the LSS, then its schedule controls the LSS output. The configuration of one of these functions is required to protect the turbine from over fueling.

## Exhaust Gas Temperature Limiting Control (EGT) PID

The intent of this controller is to limit the maximum Exhaust Gas Temperature of the turbine. The EGT PID block compares the actual EGT signal with the reference EGT signal and generates an appropriate output response signal. The EGT control PID is typically used as a limiter on the high end of the load curve of the turbine. It is also used in the GTC as an option on startup to limit the fuel flow until closed loop speed control can be reached. It will limit the fuel demand to the turbine once the EGT temperature reaches the EGT reference setpoint. The EGT Control PID has three inputs:

- Analog Input signal of EGT
- EGT temperature reference setpoint
- Feedback from the LSS

## Temperature Rate of Change Limiting Control (EGT\_DERIV) PID

The intent of this controller is to limit the maximum rate of change of the Exhaust Gas Temperature of the turbine. The EGT\_DERIV PID block compares the derivative of the EGT signal with the allowable setpoint limit of the EGT rate of change signal and generates an appropriate output response signal. The EGT\_DERIV control PID is typically used as a limiter on the startup of the turbine. It is used on startup to limit the fuel flow until closed loop speed control can be reached. The EGT\_DERIV Control PID has three inputs:

- Derivative of the EGT value (the calculated average of all T/C's)
- EGT\_DERIV temperature reference setpoint
- Feedback from the LSS

## Megawatt Limiting Control (MW\_LIM) PID

The intent of this optional controller is to limit the maximum MW output of the turbine/generator. The MW PID block compares the actual MW signal (calculated from the PT's & CT's) with the reference MW signal and generates an appropriate output response signal. The MW control PID is typically used as a limiter on the high end of the load curve of the turbine. It will limit the fuel demand to the turbine once the MW output reaches the MW reference setpoint. The MW Control PID has three inputs:

- Actual or calculated MW load input
- MW limiter reference setpoint
- Feedback from the LSS

## Auxiliary Control #1 (AUXPID\_1) PID

The intent of this controller is to provide an additional handle for the user to program additional limits into the fuel demand limiting LSS bus. The process signal, process setpoint and dynamic setting input fields will be available to the user to access via MP.

## Auxiliary Control #2 (AUXPID\_2) PID

The intent of this controller is to provide an additional handle for the user to program additional limits into the fuel demand limiting LSS bus. The process signal, process setpoint and dynamic setting input fields will be available to the user to access via MP.

## LSS Bus

The low signal select (LSS) bus selects the lowest of the PT PID, EGT PID, EGT\_DERIV PID, MW\_LIM PID, Start Ramp, Accel Limiter (PID or curve schedule), AUX\_1 PID and AUX\_2 PID signals and passes it to the HSS bus. Whichever signal is calling for the lowest fuel is the one used for LSS bus output.



## DECEL Control (Curve Schedule)

The deceleration schedule determines the minimum amount of fuel allowed during deceleration. The configuration of this function will protect the turbine from lean-blowout (loss of flame) during load transients. The demand input (forcing function) for the curve is selectable from CDP, Speed, or a MultiProg determined variable.

The decel limit curve will determine the minimum amount of fuel allowed based on the value of the input signal that was selected. The correct setup of the Decel control curve will result in the turbine recovering to synchronous speed after a load drop (as in a breaker open event). Without decel control the speed control will typically pull the fuel demand back to zero percent when the speed rises at the beginning of the load drop event, which can result in a flameout Shutdown of the turbine.

This fuel demand limiter feeds into the HSS bus. If the value is the highest on the HSS, then its schedule controls the HSS.



**Improper setup of the Decel Control options can result in this control loop opening (or limiting closure of) the fuel valve while all other control loops are requesting minimum fuel demand.**

## MultiProg Demand #1 (AUXPID\_HSS)

The intent of this block is to provide a handle for the user to program an additional limit into the fuel demand limiting HSS bus. This block will be connected to an input that will be controlled by the MultiProg program.

## HSS Bus

The HSS bus receives the output of the LSS bus, the MP demand and the decel schedule as inputs. Whichever of these inputs is higher will be the signal sent to the output of the HSS bus. This output is responsible for setting the turbine fuel valve position to maintain the requested turbine parameter.

## LSS Bus (LSS\_2)

A second low signal select (LSS) bus exists downstream of the HSS. This is where the Shutdown command is invoked to chop fuel flow to the turbine.

## Fuel Demand

This block is the true 0–100% fuel demand being commanded from the fuel control. All signals of the PIDs up to the LSS\_2 logic are 0 to 100%. This value is sent through a curve block for each fuel type (to balance BTU outputs during on-line transfers) and is then output to the Actuator driver blocks and the DeviceNet output demands for the GS series valves or the SPC module.

## Actuator Driver

The actuator driver output converts the 0-to-100% software control signal into a proportional actuator drive current signal. This can be configured for a 4–20 mA or 0–200 mA drive signal. An input from the shutdown input can override the control signal and cause the actuator to go to minimum-fuel position or shutdown. The shutdown circuit also has short and open coil fault detection. The actuator translates the signal from the electronic control into mechanical force to position the fuel valve. There are separate actuator drive outputs for gas and liquid fuel.

## DeviceNet Drivers

The GTC has a communication link dedicated for interfacing with the fuel-metering valves. It can connect directly to the GS6 or GS16 valves or connect to Servo Position Controller (SPC) driver boxes which can be configured to interface to most all other types of valves that are typically found on industrial gas turbines. Interface to 4 SPCs and 2 GS valves is provided.

## Fuel Transfer Logic

The control has the capability to run on gas or liquid fuel and the ability to make on-line fuel transfers between the two fuels. It is important to note that the packager/user will need to gather the necessary fuel property and valve flow schedule information to correctly configure the unit to make smooth on-line fuel transfers.

## Flameout Detection Logic

The Flameout section of this control includes the following options:

- EGT Temperature Monitoring (Option 1)
- Flame Detectors (discrete inputs) Sensing (Option 2)
- Flame Detectors (analog inputs) to indicate flame (Option 3)

### EGT Temperature Monitoring

The control uses EGT temperature logic to monitor for a 'Lite-off' detection in the combustor. This setpoint for this software switch is set at 400 °F (204 °C). If during any valid turbine running sequence the EGT temperature drops below this level, the control will consider this a lost flame condition and initiate a shutdown.

### Flame Detector (Discrete Input) Sensors

If a Ultra-Violet (UV) or other type of flame detector is used, the control will monitor these discrete input signals to confirm that ignition exists in the combustor. Flame is recognized by the control by a True signal on the discrete input contacts. One to four signals are supported.

### Flame Detector (Analog Input) Sensors

If analog type of flame detectors are used, the control will monitor these input signals to confirm that ignition exists in the combustor. Flame is recognized by the control by a specified (tunable) level of flame health seen by the fire-eye signals. One to four signals are supported.

## Synchronization Logic

The GTC190 control uses digital signal processing techniques to derive both true RMS voltages and relative phase of the fundamental frequencies of the bus and generator voltage wave forms. Digital signal processing techniques offer significantly improved measurement accuracy in the presence of waveform distortions, particularly since the phase measurement does not depend on zero crossings of the waveforms.

Either **phase matching** or **slip frequency** synchronizing may be selected. Phase matching method controls the turbine speed to give zero speed error and minimal phase error between the generator and bus; this provides rapid synchronizing for critical standby power applications. Slip frequency synchronizing guarantees a fixed speed difference between generator and bus. This insures the generator to be faster than the bus and initial power flow is out of the machine for larger generators. For both synchronizing methods, the GTC190 control uses actual slip frequency and breaker delay values to anticipate a minimum phase difference between bus and generator at actual breaker closure.

The synchronizer can sense a dead local bus and close the generator circuit breaker automatically when safe to do so. The built in LON network communication port on the PowerSense module allows the GTC190 to communicate power management information between controls and assures that multiple generators cannot close simultaneously onto a dead bus.

There are four synchronizer modes of operation: Off, Check, Permissive and Run. The mode can be selected through Watch Window or Modbus. The last mode selected by any of these interface methods will be the mode of operation.

OFF	(1) Disables the function of the Synchronizer block
CHECK	(2) Actively tries to match frequency & phase but does NOT close breaker
PERMISSIVE	(3) Acts as a sync check relay, outputs not active, but breaker closure command is issued if frequency and phase are within window
RUN/AUTO	(4) Normal mode with active synchronizing and breaker control

Additional synchronizer features include: voltage matching, time delayed automatic multi-shot reclosing, and a synchronizer timeout alarm. Raise and lower inputs can be used to manually adjust speed for manual synchronizing. Voltage raise and lower inputs can be used to manually adjust voltage for manual voltage matching. Each of these features may be enabled or disabled during setup.

## Load Control Options

The GTC190 control includes several different load control options:

- Simple load droop operation provides safe operation in parallel bus applications in the event of a circuit breaker aux contact failure.
- Process Control (against utility)
- VAR/Power Factor Control (against utility)
- Isochronous operation when the bus is isolated
- Isochronous Load Sharing with other units connected to the bus

When the generator circuit breaker is closed, the GTC190 can be in simple droop mode or in Isochronous Load Share mode. In the system configuration menu the user can determine the initial mode the unit will go into based upon the Generator breaker closure. The unit can go to a minimum load setpoint (manual loading) or go to a 'Base' Load setpoint programmed by the user (auto loading). Both of these are Droop mode load control loops. The user may also select that the unit stay in Isochronous mode which will allow it to immediately load share with any other units on the local bus. It will do this via the LON communication port, which interfaces to the other units. If this unit is the only one on the bus it will pick up all of the load.

Load and unload ramps provide smooth transition between autoloading, manual loading, Isochronous Load sharing and process control any time the operating mode is changed.

## Process Control

A cascade process controller is provided for controlling load based on a customer input signal. A typical example of this is to use the process control for import/export control of generated power. An adjustable bandwidth input filter, flexible controller adjustments, an adjustable deadband, and direct or indirect control action, allow the process control to be used in a wide variety of applications.

A 4–20 mA (or 1–5 Vdc) process transmitter provides the process signal to the GTC190 control. The control includes an internal digital process reference setpoint controlled by raise and lower switch contacts or by a Modbus or ServLink communication interface. The output of the process control provides the cascade load reference to the Load control.

Adjustable ramps allow smooth entry to or exit from the process control mode. When the process control mode is selected, an adjustable ramp moves the load reference in a direction to reduce the process control error. When the error is minimized, or the reference first reaches either the specified high or low load pick-up limits, the process controller is activated. When unloading from the process control, an adjustable unload ramp provides time controlled unloading to the unload trip level. When load reaches the unload trip level, the GTC190 control automatically issues a breaker open command to remove the generator set from the system. The ramp pause switch input allows holding of the load ramp for cool-down or warm-up purposes.

When multiple gensets and GTC190 controls are connected to a bus in process control mode one unit is automatically assigned as the "Process Master". Its process control loop then dictates through the LON network the load levels of other gensets on the bus.

## VAR/PF Control

The VAR/PF functions control the reactive power component of the generator in parallel systems. The reactive load mode can be configured for VAR or Power Factor control. The controller compares the reactive load on the generator with an adjustable internal reference and makes corrections to the setpoint of the Automatic Voltage Regulator (AVR) until the desired reactive power is obtained. The reactive power level can be maintained while also controlling real load through the generator breaker. The analog voltage bias output can be directly connected to compatible voltage regulators. The control also has raise and lower contact outputs to activate a voltage regulator MOP when an analog input is not provided on the AVR. The GTC190 control has a selectable voltage range alarm that is activated if the analog output to the voltage regulator reaches high or low saturation. The GTC190 control also has selectable and adjustable high and low voltage limit switches and alarm outputs.

The GTC190 control provides switch inputs to allow raising or lowering the generator voltage reference. The control also provides a 4–20 mA (or 1–5 Vdc) analog input for kVAR/PF setpoint control, if desired. The kVAR/PF reference can also be set through a Modbus or ServLink DDE communication interface.

While the GTC190 is controlling unit load to accomplish real load (MW) sharing, the voltage of the generators in parallel will be controlled to accomplish equal Power Factor levels of each generator.

## Generator Protection

The GTC190 control includes the following features as selection options for the user.

### Power and Energy Metering

The digital signal processing techniques are used to provide significantly improved accuracy and speed of response over conventional analog measurement techniques. Accuracy is improved using rapid sampling of the voltage and current signal waveforms and developing a true RMS measurement. Measuring true RMS power allows optimal accuracy, even in the presence of power line distortions.

The PowerSense board receives the PT and CT inputs for both the generator and bus for calculation of parameters for the GTC190 to use in system control. The algorithms used are based on IEEE 1459-2000. For the generator and bus the following parameters are provided: Hz, Vac, Amps, W, VA, VAR, PF, Phase, Voltage harmonics, Current harmonics, Negative Phase Sequence Voltage, Negative Phase Sequence Current.

Available for selection at the 4-20 mA analog outputs: Synchroscope, Generator metering, Mains metering

## Protective Relaying

Alarms and Trips can be configured for generator protective relay functions. Time delays for the alarm and trip thresholds can be set. The GTC190 contains programming logic to annunciate the following generator events:

- Over and Under Voltage
- Over and Under Current
- Over and Under Frequency
- Over and Under VARs
- Negative Phase Current and Voltage
- Phase Over Current
- Phase Differential Current
- Reverse Power and Over Power protection

Each of the events has an initial Warning level and an Alarm level condition that can trigger the desired action (Alarm, Open Breaker Trip, Shutdown unit Trip). Current based protections are implemented using the ANSI/IEEE C37.112 Very Inverse curve.

## Distributed I/O Programming

The GTC190 control includes a dedicated Profibus interface port to interface to a pre-defined network of distributed I/O modules. At initial release this network has been designed using Allen-Bradley Flex I/O modules and Prosoft Communication heads. The control wiring in this manual illustrates the module layout including quantities and part numbers of the components. This can be purchased directly by the user or from Woodward as a complete kit.

The GTC190 GAP application contains all of the programming logic to handle the specific communications to these modules and the associated algorithms to decode the information for each channel from the Profibus protocol. The GTC190 CORE Fuel control does not utilize any of this I/O for its functionality and therefore all of this I/O has been programmed in a generic form to create an error-free interface to these signals. The intent is that the user will program the logic associated with these I/O signals in their MultiProg program.

All of the module and channel information needed to interface to this IO has been done in a separate GAP program (part number 5418-2415.GAP). Most of the key information has been placed in B\_LIST or A\_LIST blocks. These blocks provide an organized way to find the required input or output fields to interface to the IO. They do nothing but pass the value from the input field to the output field of this block. The IO module layout and the software block name location of each of these signals in the GTC190 application can be found in the 5418-2415.GAP file.

To connect the GTC190 application software to this hardware a file must be created (applicom.ply) and placed on the control in the same folder as the GAP application. This file must be generated from the Applicom CD that is supplied with the system (install Service Pack 3 from the Woodward website after installation). If the DIO hardware is supplied by Woodward, the user can use the file delivered on the control. If the user creates this file it must contain the correct DeviceNet configuration in the same file as the Profibus configuration. Only the full layout shown in the control wiring is supported in the GTC190, although some subsets of the layout shown can be used.

## Interfacing to MultiProg

The GTC190 hardware includes a software run-time license of the ProConOS (Operating System), which supports the execution of a MultiProg (MP) application in concert with the GAP application running on the VxWorks OS. The GAP application contains a block that permits the interfacing to this external program. In addition to this a number of blocks have been added to the application in specific categories to allow MP to access some generic GAP function blocks. Ideas like placing all user accessible tunables in GAP rather than MP should help simplify the finalized site application. It is also recommended that an archived version of the MP program be placed on the Atlas hard-drive in order to better support the site in the future.

The system documentation CD contains the source codes of the Master GAP file (or sometimes called the Second-ring file) and the Fuel Control CORE file. Customers incorporating additional programming into the Atlas control will need to utilize these files. The programmer should have a good working knowledge of GAP programming and the use of the GAP editor tool, including a clear understanding of the meaning of terms template and coder versions. In most cases the GTC190 GAP file will be used as a reference in finding the software 'handles' (both input & output) of the control signals and also the tunable fields that have been programmed as being available to the MultiProg programming environment. Input fields that are available for MP control are identified with a boxed mp designation. The programmer can pass any GAP block output field to MultiProg for use in programming. The GTC190 does not include the application tool required to write the program that is intended to reside on the GTC.

Additional programming help can be found in the GAP help file that will assist the programmer in interfacing the 2 programs together.

## Special Features of the GTC

The GTC190 also contains a few special features that the user may be interested in using. These tools may require the user to have a deeper level of understanding of the Woodward control and software products than is required to just configure and run the unit. However, anyone capable of commissioning a unit should be able to utilize these features, and instruct others on how & when to use them.

**Debug Tunables**—There are additional tunables in the control application that are not available in the service and configure headers. These are intended to be used only if needed by experienced personnel. There are also numerous tunable blocks that have been setup just to be available to the MP application.

**Non-Volatile Memory**—The application has logic that will keep an incremental count of the following:

- Number of Starts Attempted
- Number of Fired Starts (Start & Temp seen)
- Number of Shutdowns (Hard shutdowns only)
- Total Turbine Run Hours (Fuel On & Temperature seen)
- 16 additional values to come from MP

The control will save these values periodically to a non-volatile memory location so that these values will not be lost upon a power cycle to the control. These accumulated values are sent to the Modbus list. There are tunable handles in the application to preset these accumulators to any desired value when the control is being initially installed or when the control is replaced.

**Data logging**—The GTC has a high-speed datalog block included in the application that allows the control to trend a pre-programmed number of parameters at a rate of 10 ms increments. These values are stored in an accumulation buffer that will retain approximately 20-100 seconds of run time, depending on how many parameters are programmed. This block is setup to automatically start once the turbine has achieved a successful start and will automatically stop the log anytime a shutdown event occurs. At this point the control will create an archive file of this data and place this file on the Atlas hard drive. On the next start the control will initiate a new datalog file and repeat the process. The files will be incremented as DATALOG\_1, DATALOG\_2 and DATALOG\_3 and after 3 files have been created it will over-write the oldest file.

This file can be downloaded and viewed with the Control Assistant tool. This file can be very valuable in troubleshooting dynamic control issues or intermittent shutdowns.



# Chapter 3.

## Installation and Wiring Guidelines

### Introduction

For general information on unpacking the unit, mounting the unit, shielding and grounding signals refer to the AtlasPC digital control manual (85586). This chapter is intended to guide the user in specific control wiring of the I/O signals used in the GTC190 application.

### Electrical Connections

For noise suppression, it is recommend that all low-current wires be separated from all high-current wire.

Most inputs and outputs to the GTC190 are made through “CageClamp” terminal blocks. The GTC190 is shipped with mating connectors for all terminals. Most of the GTC190 control’s terminal blocks are designed for removal by hand. After GTC190 input power is disconnected, the pluggable terminal blocks can be removed one at a time by pulling them straight out. Be careful not to pull the plug out at an angle, as this can fracture the end terminal.

Each Terminal block has a label (PS, PSEN, ANA1, ANA2, SCM or MAIN) to indicate which board it is used with, and terminal numbering to indicate which terminal block on that board to plug into. The board assemblies also are marked with a label to match with terminal block labels.

The pluggable terminal blocks are screwless CageClamp-style blocks. The spring clamp can be opened with a standard 2.5 mm (3/32 inch) flat bladed screwdriver (see Figure 2-2). The GTC190 pluggable terminal blocks accept wire 28 to 18 AWG (0.08 to 0.8 mm<sup>2</sup>). One 18 AWG (0.8 mm<sup>2</sup>) wire, or two 20 AWG (0.5 mm<sup>2</sup>) wires, or three 22 AWG (0.3 mm<sup>2</sup>) wires can be easily installed in each terminal. Wires for the pluggable I/O terminals should be stripped 8 mm (0.3 inch).

The GTC190 fixed terminal blocks used for the power supply input accept wires from 28 to 18 AWG (0.08 to 0.8 mm<sup>2</sup>). One 18 AWG (0.8 mm<sup>2</sup>) wire, or two 20 AWG (0.5 mm<sup>2</sup>) wires, or three 22 AWG (0.3 mm<sup>2</sup>) wires can be easily installed in each terminal. Wires for the fixed mounted power terminals should be stripped 5 mm (0.2 inch).

#### **IMPORTANT**

**Do not tin (solder) the wires that terminate at the GTC190 terminal blocks. The spring-loaded CageClamp terminal blocks are designed to flatten stranded wire, and if those strands are tinned together, the connection loses surface area and is degraded.**

All ac wiring for voltages and currents is done with fixed screw barrier blocks rather than pluggable terminal blocks. The fixed screw barrier blocks accept wires terminated into terminal lugs for #6 screws.

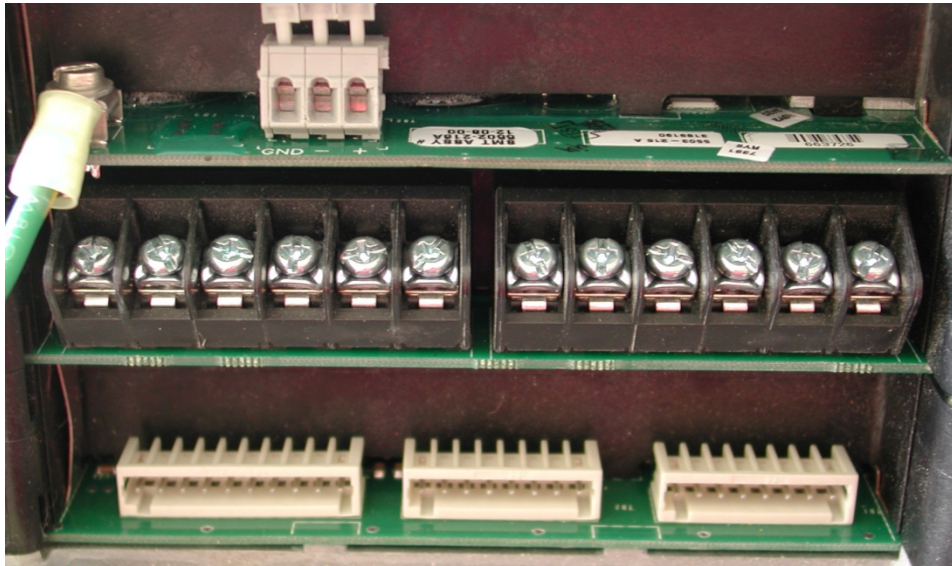
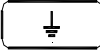

Figure 3-1. Fixed Ring Terminals

## Grounding for Protection Against Electrical Shock

Protective Earth (PE) must be connected to the termination point on the backside

of the unit next to the label with the symbol  (or 1 of 3 other like termination points without label) to reduce the risk of electric shock. This connection will be made using a thread-forming screw (M4 x 6 mm). The conductor providing the connection must have a properly sized ring lug and wire larger than or equal to 3.3 mm<sup>2</sup> (12 AWG).

## Recommended Grounding Practices

Providing the proper ground for the GTC190 is important. Improper connection of the GTC190 chassis to the ground plane may lead to stray currents between the reference point for the ac signal sources (current and voltage transformers), and the reference point for the sensing inputs on the GTC190. Differences in potential between these two points results in equalizing current flow which then produces unacceptably high common mode voltages. Common mode voltages may result in improper readings for the sensed ac inputs, or even damage to the GTC190 in extreme cases. To minimize this problem, it is necessary to provide a low resistance path between the ac signal reference point, and the chassis of the GTC190. Typically this point is the designated ground for the generator set and related instrument transformers.

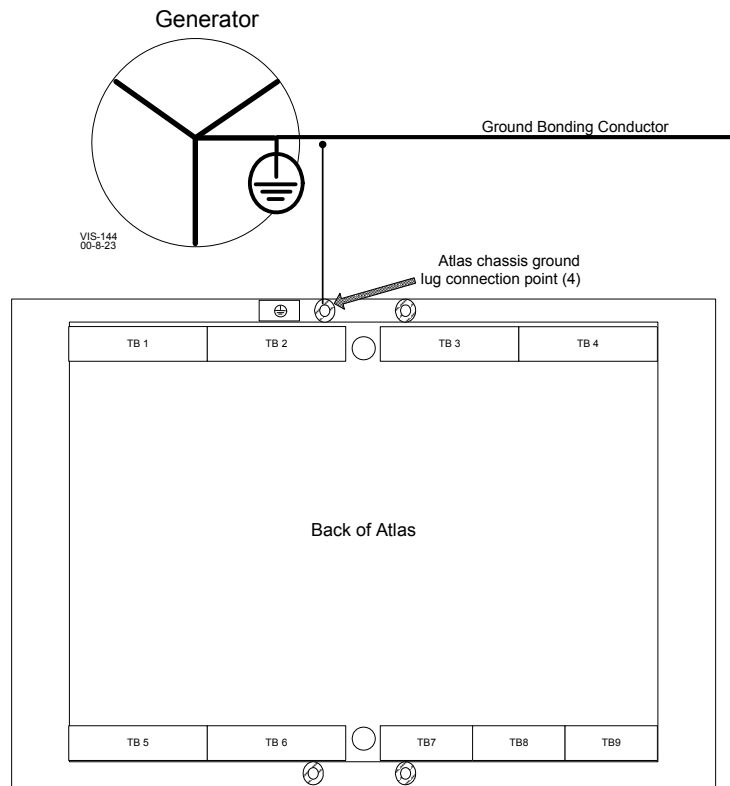

Figure 3-2. Recommended Single Point Grounding Scheme

## Isolation

Figure 3-3 shows how the I/O is isolated with regard the main system power supply and other I/O types. Each input wiring diagram also shows how an input type is isolated in more detail.

Figure 3-3 uses numerals to indicate isolation grouping. Power and Ground isolation groups are indicated with a P# and G#. Every instance of the same P# and G# indicates that the item is part of the same group and not isolated from the other members of the same group. For example, all analog inputs, analog outputs, and CPUs use P9 for power and G9 for ground.

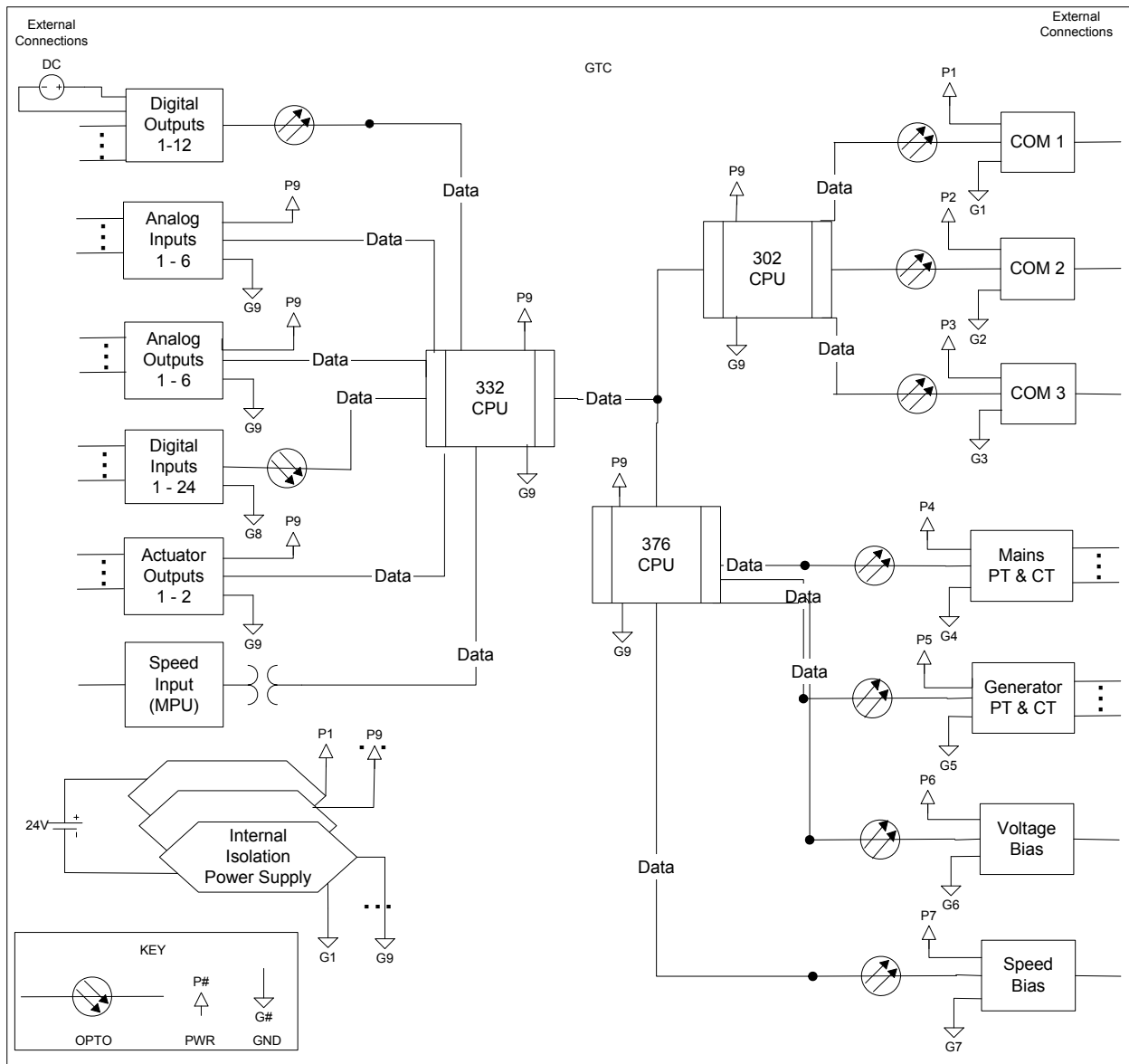
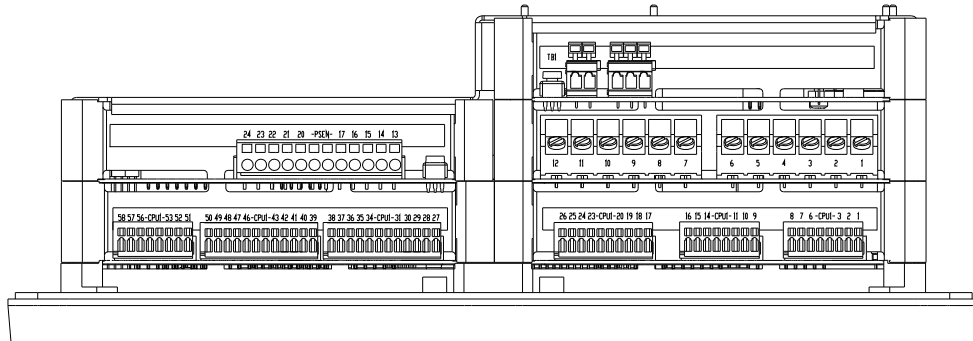

Figure 3-3. I/O Isolation

## Terminal Locations

All terminals are located on the top and bottom of the GTC190. All but the PT and CT use either a cage clamp or a pluggable terminal strip for ease of connection. Figure 3-4 shows top and bottom views of the GTC190 to help orient each of the three board positions within the control. Each board's Wiring Diagram is shown immediately following the top and bottom terminal views.



(Top View)

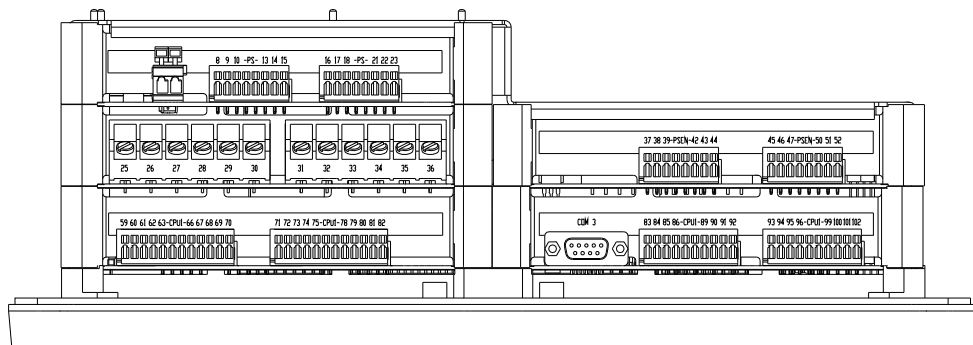

(Bottom View)

Figure 3-4. Atlas Terminal Strip Location View

## Input Power

### **! WARNING**

The GTC190 power supply board must have the input power removed before installing or removing any connectors or wiring.

This equipment is suitable for use in Class 1, Division 2, Groups A, B, C, and D, or non-hazardous locations only.

The GTC190 is suitable for use in European Zone 2, Group IIC environments per DEMKO certification.

Wiring must be in accordance with Class I, Division 2 wiring methods and in accordance with the authority having jurisdiction.

Do not connect more than one main power supply to any one fuse or circuit breaker.

The power supply and ground connections are located on the top of the GTC190 on the power supply board. The input to the Power supply must be of a low impedance type for proper operation of the control. DO NOT power a control from a high voltage source containing dropping resistors and zener diodes. If batteries are used for operating power, an alternator or other battery-charging device is necessary to maintain a stable supply voltage.

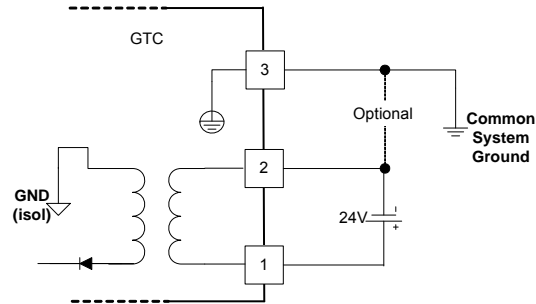

Figure 3-5. Input Power Wiring Diagram

## Input Power Ratings

Voltage Range	18–32 Vdc
Maximum Voltage	40 Vdc
Minimum Voltage	9 Vdc (engine cranking only)
Input Current	0.9 A @ 24 Vdc 1.1 A @ 18 Vdc
Maximum Input Power	22 W
Typical Input Power	20 W @ 24 Vdc
Interrupt Time Holdup	8 ms @ $\geq 24$ Vdc input voltage
Efficiency	70% minimum over operating input voltage range
Reverse Polarity Protection	100 Vdc
Input Wiring Constraints	The GTC190 must be wired such that no other device receives power from the wiring between the unit and the power supply source.
Input Wire Size	12 AWG (2.5 mm <sup>2</sup> )
Input Fuse Rating	3 A (time delay with melting I <sup>2</sup> t $\square$ 100A <sup>2</sup> sec)

Significant inrush currents are possible when current is applied to the GTC190 control. The magnitude of the inrush current depends on the power source impedance, so Woodward cannot specify the maximum inrush current. Time-delay fuses or circuit breakers must be used to avoid nuisance trips.

## Power Supply Monitoring Circuit

Maximum voltage measured	35 Vdc
Resolution in volts	0.15 Vdc
Maximum error due to temperature change	1.0 Vdc
Maximum error due to load change	1.0 Vdc
Total maximum error at 25 °C	1.2 Vdc

## Input Power Wiring

Protective earth ground (PE) must be connected to the chassis at the  labeled termination point on the back of the display. The power supply grounding terminals should also be connected to earth to ensure grounding of the power supply printed circuit boards. The grounding conductor must be the same size as the main supply conductors or the PT wires, whichever is larger.

Note that the control's power supplies are not equipped with input power switches. For this reason, some means of disconnecting input power to each main power supply must be provided for installation and servicing.

It is expected that the installation of this equipment will include overcurrent protection between the power source and the GTC190. This overcurrent protection may be accomplished by series connection of properly rated fuses or circuit breakers. Branch circuit protection of no more than 250% of the maximum GTC190 power supply input current rating must be provided. Maximum fuse rating must meet the 250% UL listing requirements. The use of properly sized UL class CC, J, T, G, RK1, or RK5 fuses meet the requirements for branch circuit protection. Do not connect more than one GTC190 to any one fuse. Use only the wire size specified above, or equivalent, that meets local code requirements. Time delay fuses should be used to prevent nuisance trips.

The power supply holdup time specification is the time the supply will continue to operate within specification after its input power is interrupted. This information may be useful in specifying uninterruptible power supply (UPS) systems.

### **IMPORTANT**

**2.5 mm<sup>2</sup> (12 AWG) is the largest wire gauge size that can be connected to the control power input terminal blocks.**

**The minimum continuous input voltage allowed is 18 V at the power input of the control. The length, size of wire, and load current will determine the minimum supply output voltage. The minimum supply voltage measured at the source should always be greater than 18 V. Example: two (source and return) 20 foot (6 m) lengths of 14 AWG (2.5 mm<sup>2</sup>) wire carrying 1.2 A (maximum rated current) will result in a voltage drop from source output to control power input of approx. 0.16 volts. The resulting supply voltage from the example must be greater than 18.16 volts.**

**The GTC190 will remain in operation when an electrical starter is engaged, if input power drops to no less than 9.0 V.**

# Chapter 4.

## PowerSense Signal Wiring

### PowerSense Board Wiring Pinout

The PowerSense board (**PSEN**) is mounted between the Power Supply and the SmartCore board. The PowerSense Board inputs are the Mains and Generator power monitoring. Each PowerSense board contains the circuitry for two sets of three phase ac voltage (PT) and ac current (CT) inputs, as well as a speed bias output, a voltage bias output, and a LON communications port.

#### Features

- On-board processor for automatic calibration of the I/O channels
- PT and CT inputs provide fundamental as well as harmonic information
- PT and CT inputs are updated after 3 cycles, which is 50 ms at 60 Hz
- PT and CT inputs and bias outputs have 12 bit resolution
- PT inputs are software configurable for 70 V, 120 V, or 240 V ranges
- Each set of PT and CT inputs is isolated from the rest of the board and chassis
- Speed bias output is software configurable for 4–20 mA, 0–5 V, PWM, or  $\pm 3$  V output
- Voltage Bias output is software configurable for 4–20 mA,  $\pm 1$  V,  $\pm 3$  V, and  $\pm 9$  V
- Speed Bias and Voltage bias outputs are isolated from the rest of the board
- LON communication port

### Potential Transformer (PT) Inputs

The Generator and Mains ac voltage inputs can accept voltages up to 300 Vac RMS maximum between the positive and negative terminals of each input. The inputs may be connected line-to-line or line-to-neutral. For example, if the inputs are connected line-to-neutral, each input A-N, B-N, and C-N may have up to 300 Vac. Therefore, a 480 Vac generator may be wired to the GTC190 using line-to-neutral connections resulting in 277 Vac at the inputs.

Input Voltage Range Selections	70, 120, 240 Vac RMS
Max. Input Voltage	300 Vac
Input Current	3 mA maximum
Input Frequency	40–70 Hz
Common Mode Rejection Voltage	$\pm 450$ Vdc minimum
Common Mode Rejection Ratio	-63 dB minimum

The GTC190 must be configured for a voltage range relative to the input (Potential Transformer secondary) provided. For example, if a phase (+) to phase (–) input to the GTC190 is to be a nominal of 70 Vac, set the range to the 70 volt range. No change in wiring is necessary. This configuration setting maximizes the accuracy for the voltage level being sensed. There is also a voltage floor below which a voltage cannot be detected so setting the correct range is important for more than just accuracy. See the table below for the voltage floor at each range.



Voltage Range	Dead bus Voltage Detected	Maximum Voltage Detected
70	27 Vac	100 Vac
120	40 Vac	150 Vac
240	80 Vac	300 Vac

If potential transformers are used, be careful to select an accurate transformer. The largest source of inaccuracy in the system will be the transformer, since even the most accurate transformer is less accurate than the ac voltage inputs to the GTC190. The calibration menu contains turns ratio compensation factors for each PT input. Follow the calibration procedure to negate much of the transformer error.

When the PT input to the control is conditioned with a transformer the generator and mains transformer ratio is entered into the GTC190. This is described in the Configuration section of the Operation Manual. The GTC190 will use the PT ratio and the entered configured Range to calculate the actual system voltage(s).

**EXAMPLE:**

Hwd range = 120

PT ratio = 4

Measured PT secondary (input at terminals) = 112.5 Vac

The GTC190 will display 450 Vac for this input voltage.

## Hazardous Live

The following circuits are classified as Hazardous Live because they carry potential shock hazardous voltages during normal operation or under single fault conditions:

- Potential transformer (PT) inputs
- Current transformer (CT) inputs
- Voltage bias outputs



**WARNING**

**HIGH VOLTAGE—Do not touch or make contact with the above inputs and outputs during system operation when such circuits are live. Possible serious personal injury or death could result.**

These inputs and outputs are provided with 500 V of dielectric isolation from chassis ground. In addition, these inputs/outputs are isolated from safety extra-low voltage (SELV) circuits (such as serial communication, PC/104 circuits) by optoisolators or transformers provided with double insulation and 3 000 Vac of dielectric isolation.

## PT—3Ø Wye, L-N, No Transformers

No transformers are necessary if the voltage input to the GTC190 is less than 300 Vac at a given phase input. This diagram shows a system where both the generator and bus are less than 300 Vac measured line-to-neutral. Each is connected to the GTC190 in a L-N mode without transformers (PT Ratio = 1:1). It is not required that both the mains and the generator inputs be connected in the same manner. One could be L-L and the other L-N if preferred. Also, one could use transformers and the other not. The diagram shown is simply an example of a typical system.

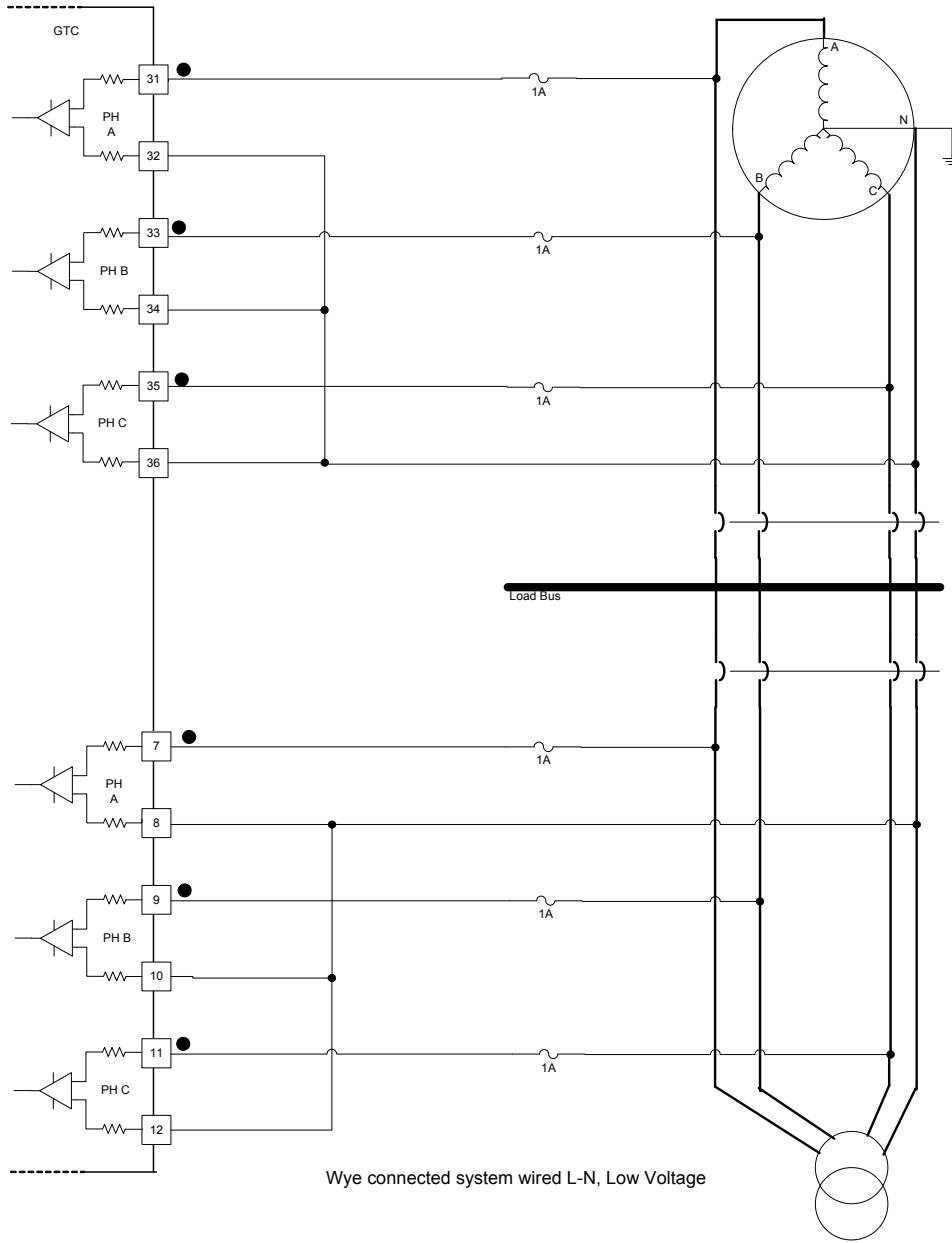

Wye connected system wired L-N, Low Voltage

Figure 4-1. PT Wiring—3Ø Wye, L-N, without Transformer

**PT—3Ø Wye, L-N, with Transformers**

Transformers are necessary if the voltage input to the GTC190 is greater than 300 Vac at a given phase input or a customer preference. This diagram shows a system where both the generator and bus utilize potential transformers. Each is connected to the GTC190 in a L-N mode. It is not required that both the mains and the generator inputs be connected in the same manner. One could be L-L and the other L-N if preferred. Also, one could use transformers and the other not. The diagram shown is simply an example of a typical system.

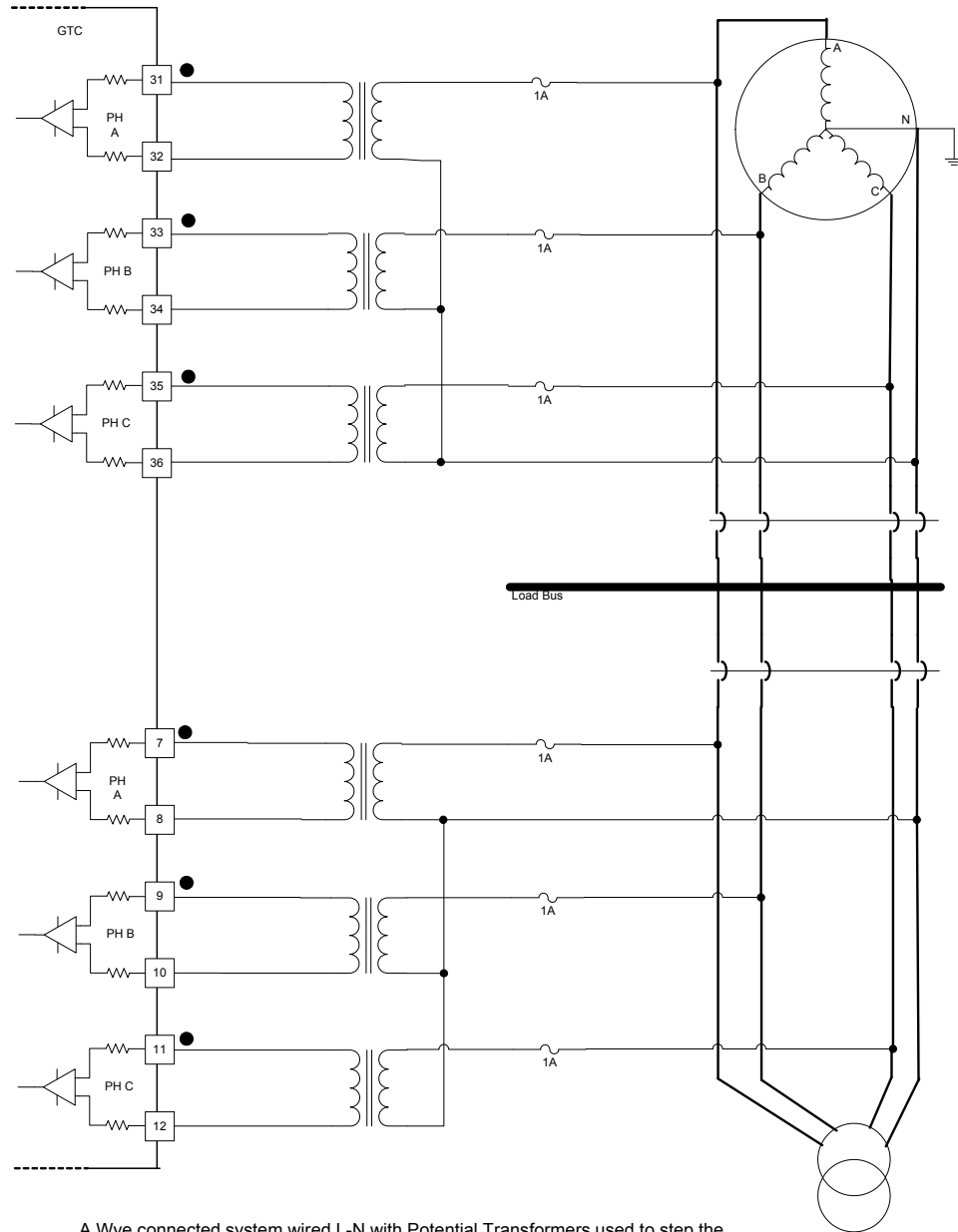

A Wye connected system wired L-N with Potential Transformers used to step the voltage down.

Figure 4-2. PT Wiring—3Ø, Wye, L-N, with Transformer

**PT—3Ø Wye, L-L, with Transformers**

Transformers are necessary if the voltage input to the GTC190 is greater than 300 Vac at a given phase input or a customer preference. This diagram shows a system where both the generator and bus utilize potential transformers. Each is connected to the GTC190 in a L-L mode utilizing open delta wired transformers. It is not required that both the mains and the generator inputs be connected in the same manner. One could be L-L and the other L-N if preferred. Also, one could use transformers and the other not. The diagram shown is simply an example of a typical system. Notice for this configuration that the generator is a Wye, but the potential transformers are connected in a L-L fashion, so the GTC190 should be configured as a Delta L-L.

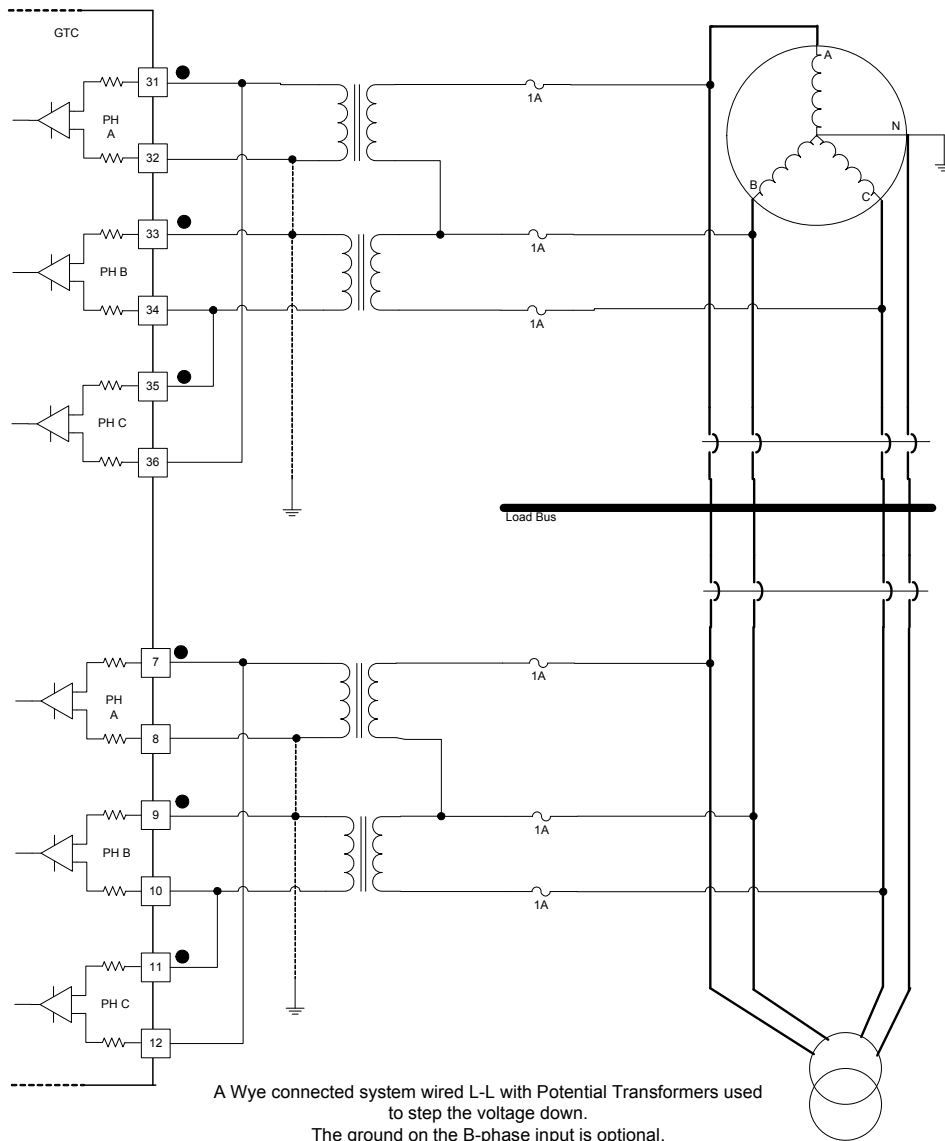

Figure 4-3. PT Wiring—3Ø Wye, L-L, with Transformers

### PT—3Ø & 1Ø Inputs, Wye, L-L with Transformers

Transformers are necessary if the voltage input to the GTC190 is greater than 300 Vac at a given phase input or a customer preference. A single phase monitoring system may be wired either L-L or L-N. The B and C phase inputs will be ignored and do not need to be wired. Single phase mode must then be selected in the software configuration.

The generator and mains do not have to be configured identically. One can use single phase and the other can use three phase if preferred. The below wiring diagram example shows the generator wired 3Ø with open delta transformers from a Wye system. It also shows the mains wired 1Ø with a step down transformer wired L-L.

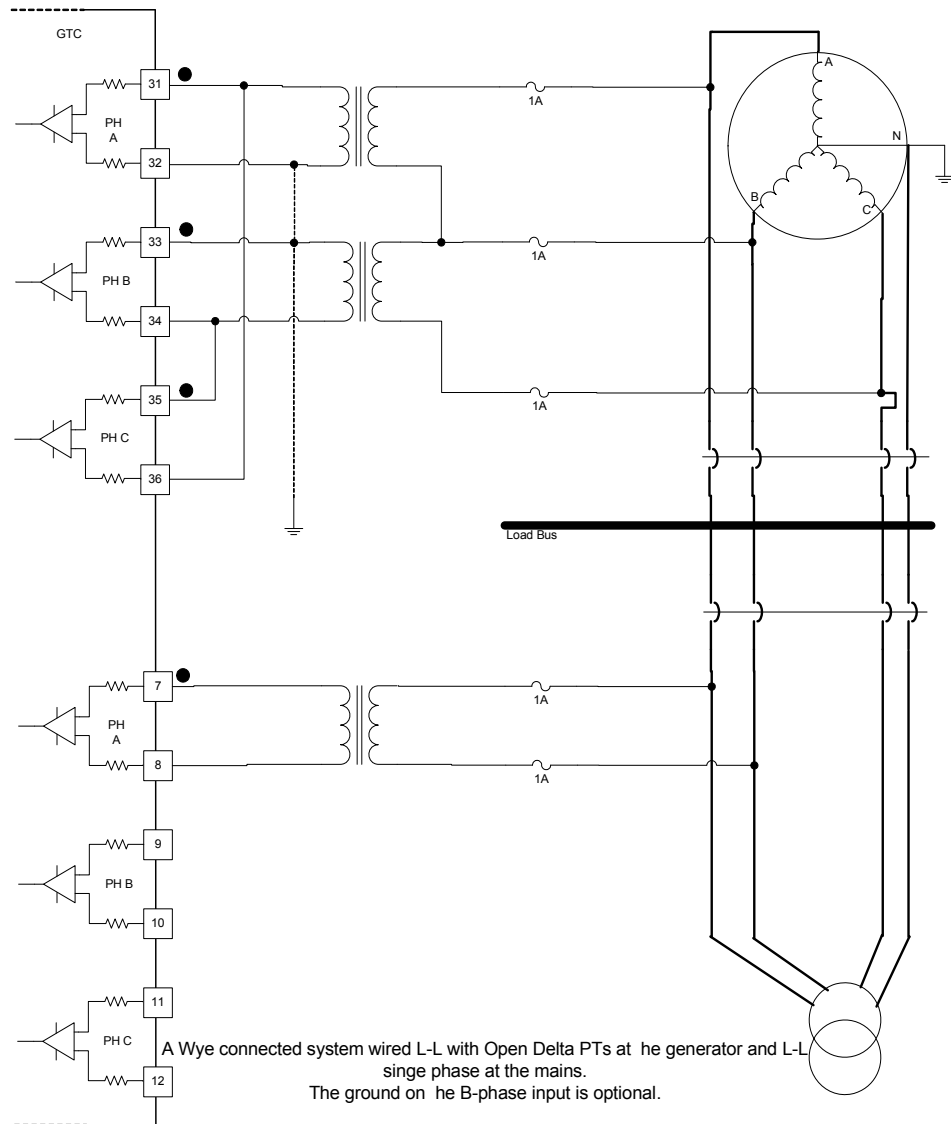

Figure 4-4. PT Wiring—3Ø Wye, & 1Ø Wye, L-L, with Transformers

**PT—3Ø Input, Delta, L-L Connection with Transformers**

Transformers are necessary if the voltage input to the GTC190 is greater than 300 Vac at a given phase input or transformers may be used per customer preference. This diagram shows a system where both the generator and bus utilize potential transformers. Each is connected to the GTC190 in a L-L mode utilizing open delta wired transformers. It is not required that both the mains and the generator inputs be connected in the same manner. One could use transformers and the other not. The diagram shown is simply an example of a typical system.

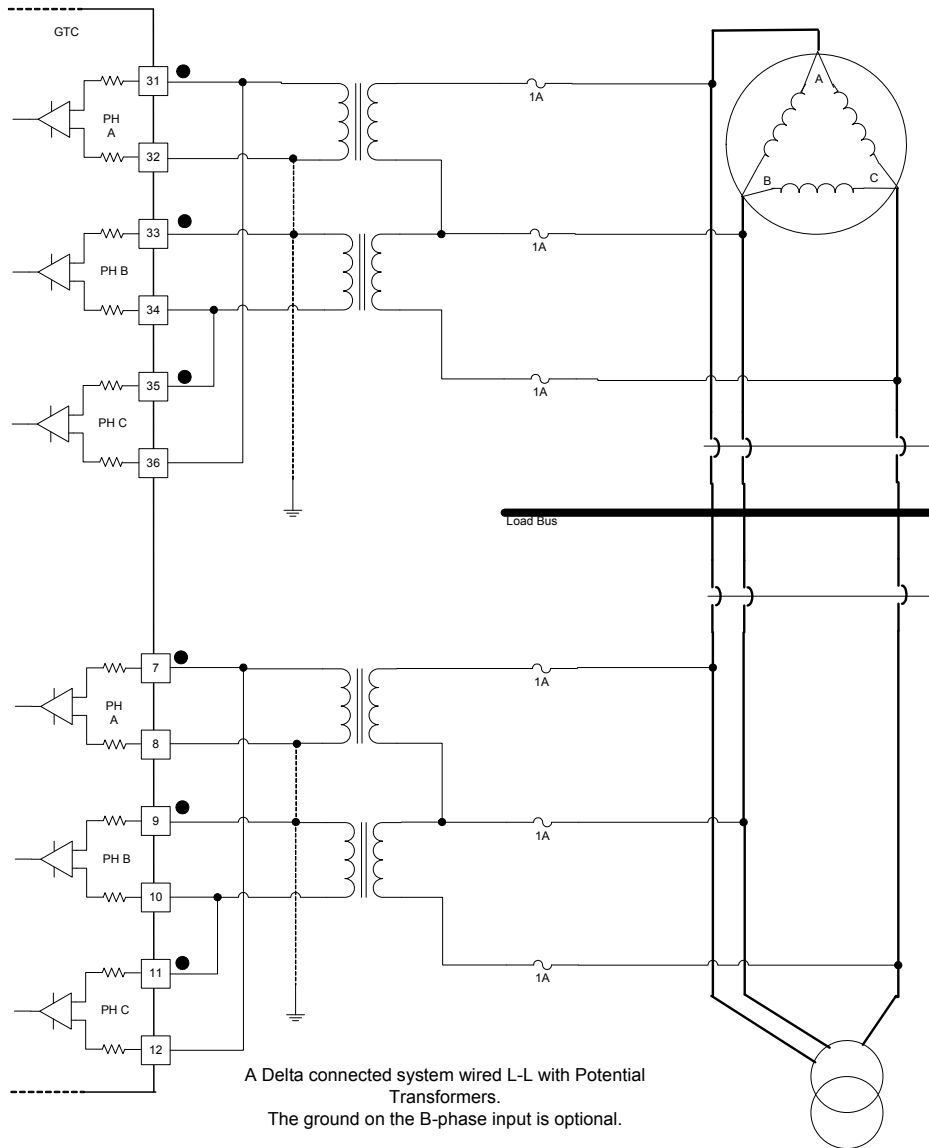

Figure 4-5. PT Wiring—3Ø Delta, L-L, with Transformers

### PT—3Ø Input, Delta, L-L Connection without Transformers

Transformers are necessary if the voltage input to the GTC190 is greater than 300 Vac at a given phase input or a customer preference. This diagram shows a system where the generator and the bus do not utilize potential transformers. Each is connected to the GTC190 in a L-L mode. It is not required that both the mains and the generator inputs be connected in the same manner. One could use transformers and the other not. The diagram shown is simply an example of a typical system.

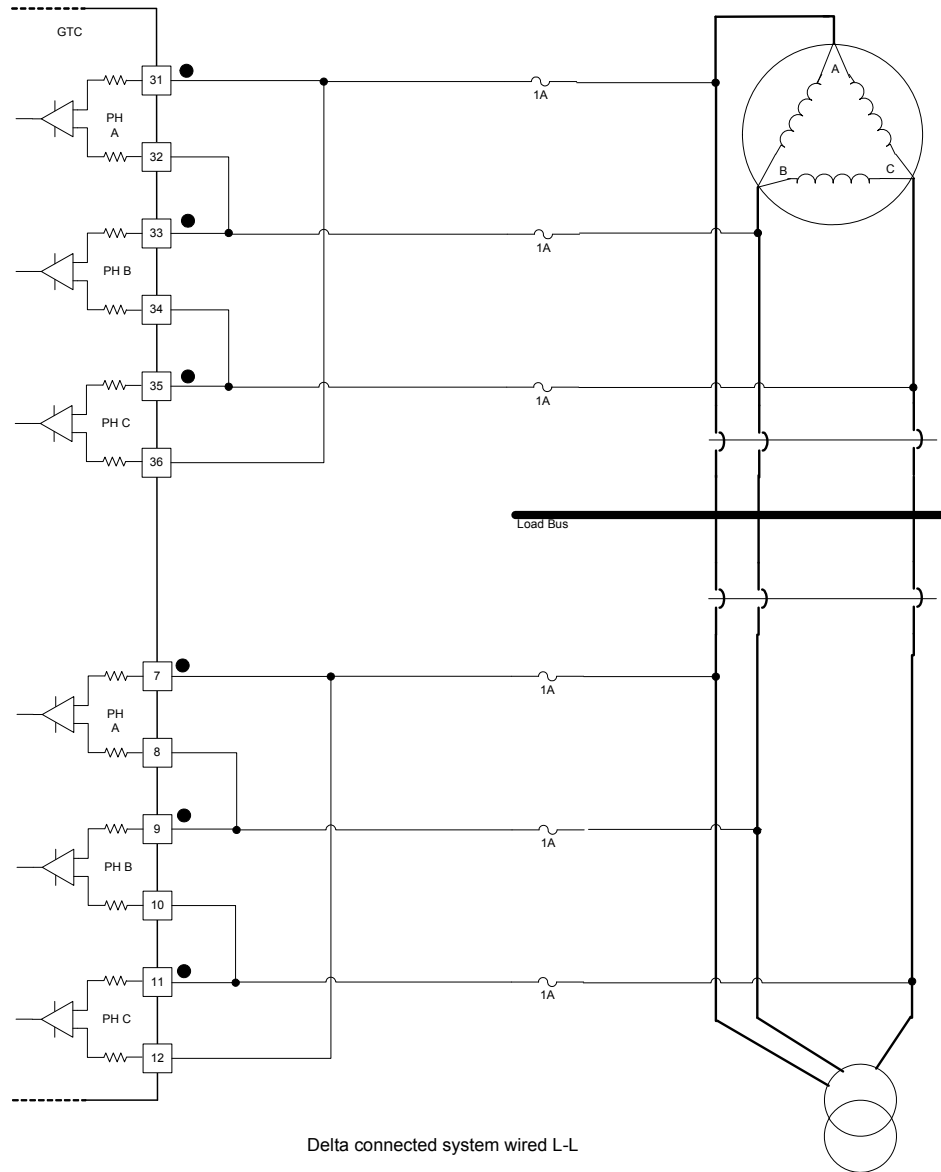

Figure 4-6. PT Wiring—3Ø Delta, L-L, without Transformers

## Current Transformer (CT) Inputs

The Generator and Mains ac current inputs can accept currents up to 7 A ac RMS maximum between the positive and negative terminals of each input. The CT inputs are rated at 5 A ac RMS nominal and function down to 50 mA. For optimum accuracy in the usable range, it is recommended to use 5 A secondary CTs (Do not use 1 A secondary CTs).

Input Current	5 A RMS full scale
Max. Transient Input Current	7.07 A RMS
Input Frequency	40–70 Hz
Common Mode Voltage	±250 Vdc minimum
Common Mode Rejection Ratio	–63 dB minimum

Be careful to select an accurate current transformer. The largest source of inaccuracy in the system will be the transformer since even the most accurate transformer is less accurate than the AC current inputs to the GTC190. The calibration menu contains turns ratio compensation factors for each CT input. Follow the calibration procedure to negate much of the transformer linear error.

The GTC190 does not require three phases for current calculations. The user can configure the GTC190 for single phase, and all functionality will be modified accordingly. The phase input that must be provided is the A phase.

The generator and mains Current Transformer ratio is entered into the GTC190. This is described in the Configuration section of the Operators Manual (26137). The GTC190 will use the CT ratio to calculate the actual system current(s).

### EXAMPLE:

CT ratio = 500

Measured CT secondary (input at terminals) = 3.9 A

The GTC190 will display 1950 A ac for this input current.

For a full wiring connection, combine the Current Transformer (CT) wiring below with the Potential Transformer (PT) section above.

### CT—3Ø Wye

This diagram shows the generator and mains in a wye configuration. The current transformers are placed on the leads connecting to the load. The diagram shown is simply an example of a typical system.



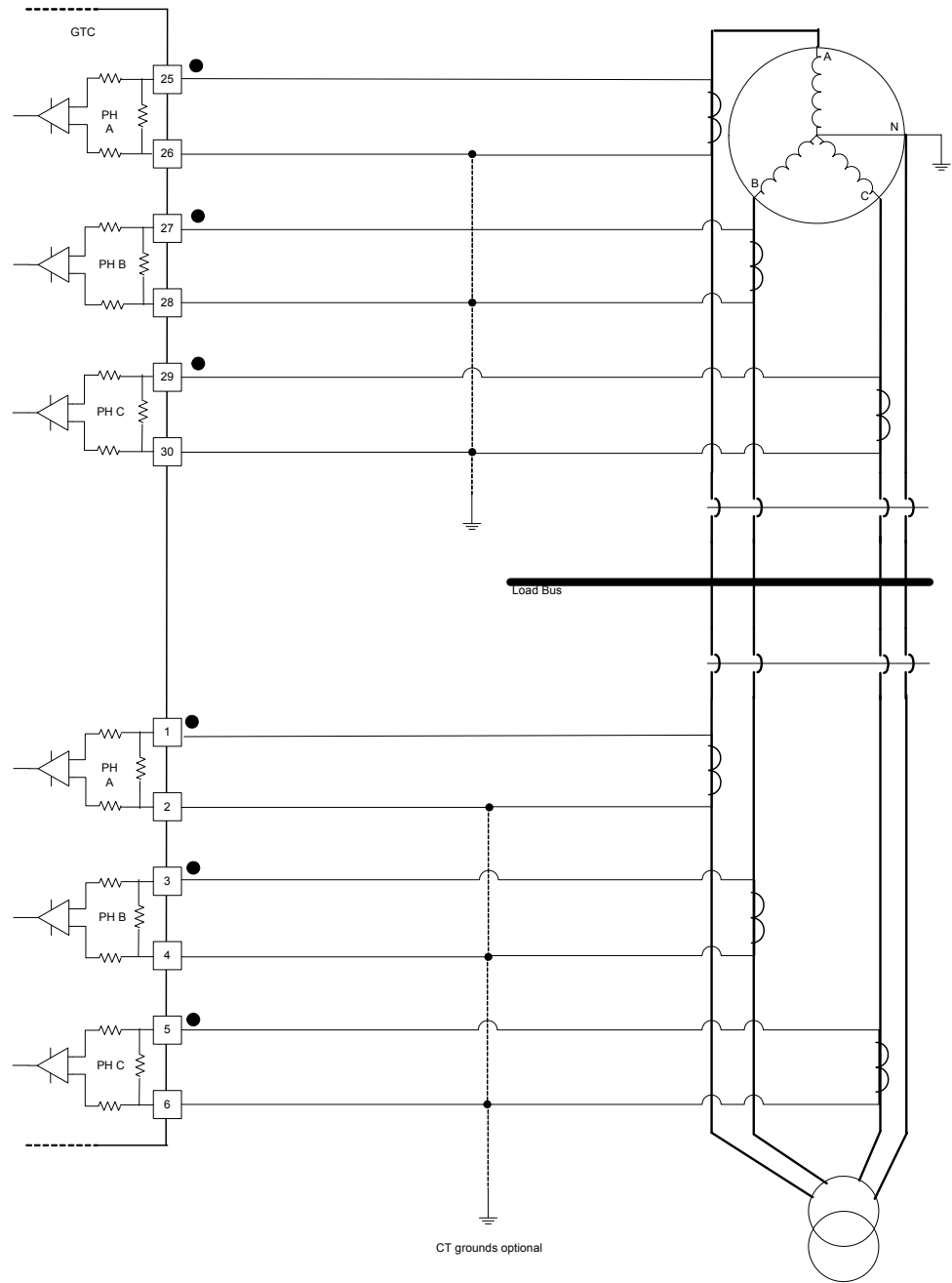

Figure 4-7. CT Wiring—3Ø Wye

**CT—3Ø Delta**

This diagram shows the generator and mains in a delta configuration. The current transformers are placed on the leads connecting to the load. The diagram shown is simply an example of a typical system.

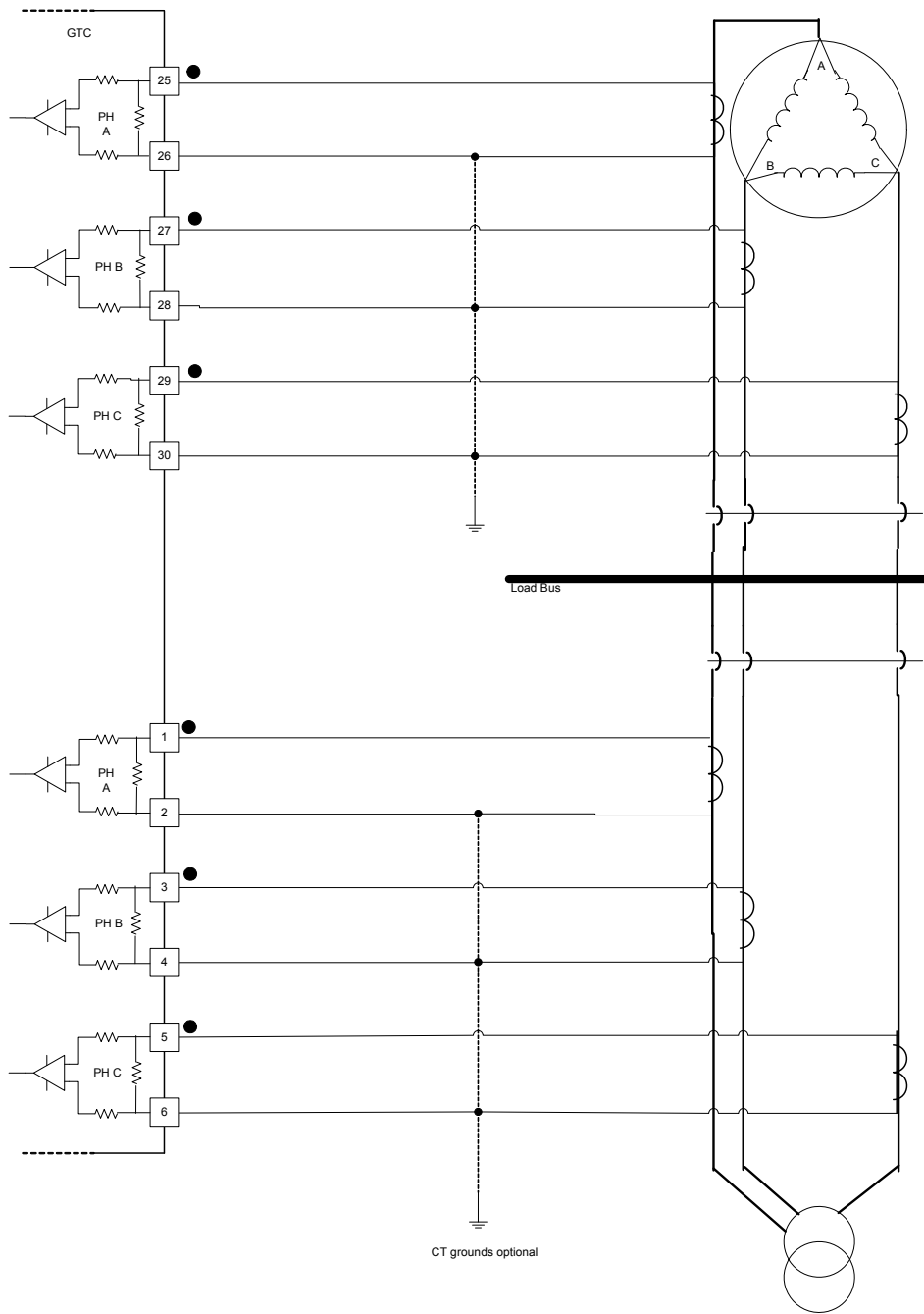

Figure 4-8. CT Wiring—3Ø Delta

## Single Phase Monitoring

In a single phase monitoring system, the GTC190 will only use the A phase CT input. Anything connected to the B and C phase inputs will be ignored. The current transformer is placed on the A phase leads connecting to the load. See the appropriate diagram above and ignore the B and C phase inputs. For a single phase input, the PT and CT must be monitoring the same phase. During control Configuration the software must be selected to use Single Phase. The single phase monitoring is applied to 3 phase machines, it is not intended for single phase machines.

### IMPORTANT

The GTC190 power calculations are based on a per-phase calculation. When a single phase input is used the displayed values will be 1/3 of the total device levels. Therefore the entered CT ratio or the total power level(s) for the mains or generator will have to be adjusted to display actual 3Ø device power levels.

## Speed Bias Output

The Speed Bias output is not used on the GTC190 and a variable configuration analog output signals that can be used by the customer.

## Voltage Bias Output

The Voltage Bias allows the GTC190 to vary the generator voltage level to control the reactive load on the generator. The Voltage Bias can be configured one of four types of outputs: 4–20 mA,  $\pm 1$  V,  $\pm 3$  V,  $\pm 9$  V. The output mode selected should be determined based on the voltage regulator specifications. Minimum to maximum voltage bias output change from the GTC190 should be approximately  $\pm 10\%$  change in rated generator voltage. Both the configuration and the wiring must be changed to switch between current and voltage outputs. Only the configuration must be changed to switch between the differing voltage outputs.

<b>PWM frequency</b>	3 kHz for current and voltage outputs
<b>Current output</b>	4–20 mA selected by software switch and wiring
<b>Voltage output</b>	$\pm 1$ , $\pm 3$ , $\pm 9$ Vdc selectable by software switch and wiring
<b>Max current output</b>	
4–20 mA output	25 mA $\pm 5\%$
<b>Max voltage output</b>	
$\pm 1$ , $\pm 3$ , $\pm 9$ Vdc	$\pm 9$ V limit $\pm 5\%$
Isolation	See HAZARDOUS LIVE isolation requirement
<b>Max load resistance</b>	
4–20 mA	300 $\Omega$ at 24 mA
$\pm 1$ , $\pm 3$ , $\pm 9$ Vdc	No maximum
<b>Min load resistance</b>	
4–20 mA	0 $\Omega$
$\pm 1$ , $\pm 3$ , $\pm 9$ Vdc output	7 k $\Omega$
<b>Resolution</b>	
4–20 mA	12 bits
$\pm 1$ V output	>7 bits
$\pm 3$ V output	>9 bits
$\pm 9$ V output	12 bits
<b>Accuracy</b>	Better than $\pm 0.1\%$ of full scale @ 25 °C
4–20 mA	$\pm 0.025$ mA
$\pm 1$ V, $\pm 3$ V, $\pm 9$ V output	$\pm 0.018$ V

**Temperature Drift**

Voltage outputs 330 ppm/°C, maximum  
 4–20 mA output 140 ppm/°C, maximum

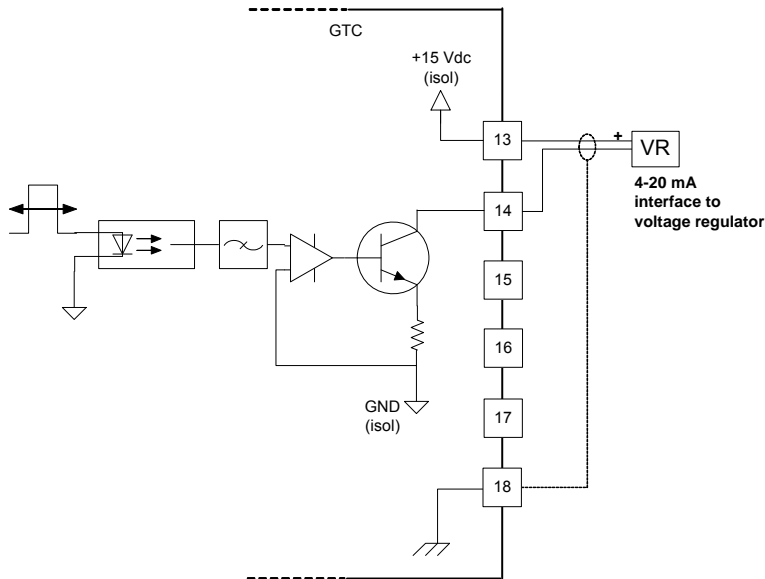

Figure 4-9. Voltage Bias Wiring Diagram, 4–20 mA Output

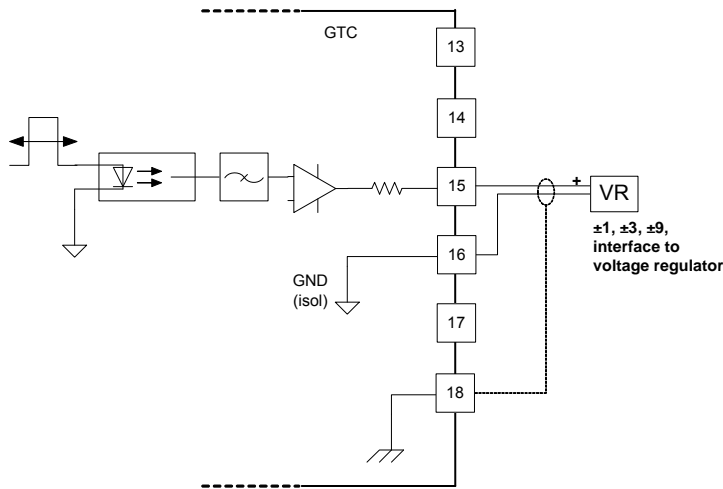

Figure 4-10. Voltage Bias Wiring Diagram, Bi-polar Voltage Output

**LON Communication Port**

The LON port is used to communicate with up to 16 other GTC190 devices. The LON allows controls to share breaker status and load share information between generator sets. The LON communication is also compatible with Digital Synchronizer and Load Control (DSL/C) devices. When an GTC190 is the last device of the LON string, the termination jumper at 48 and 49 should be installed

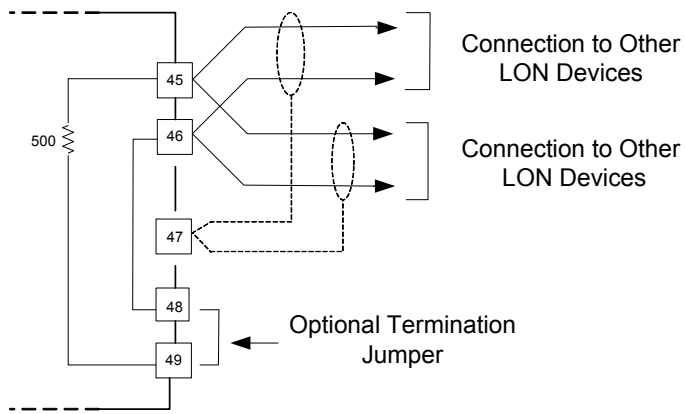

Figure 4-11. LON Connections

Use only recommended shielded cabling for LON network. Correct cable is available from Woodward, Belden, or other suppliers providing an equivalent cable.

Woodward part number 2008-349

Belden  
 PO Box 1980  
 Richmond IN 47375  
 Telephone (317) 983-5200

**Belden Part**

Number	Description
9207	PVC 20 AWG shielded. NEC Type CL2, CSA Cert. PCC FT 1.
89207	Teflon 20 AWG shielded, Plenum version. NEC Type CMP, CSA Cert. FT 4.
YR28867	PVC 22 AWG shielded.
YQ28863	Plenum 22 AWG shielded.

**Recommended cable length and stub length of LON network wiring.**

System Ambient Temperature Range:	0 to 55 °C	-20 to +55 °C	-40 to +55 °C
Maximum Network Cable Length	150 m	150 m	50 m
Maximum Stub Length	300 mm	300 mm	300 mm

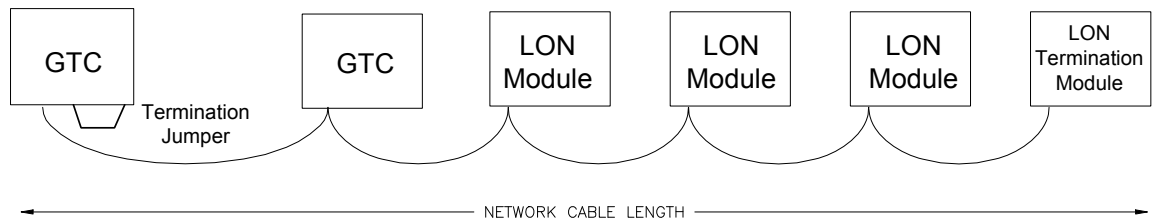

Figure 4-12. Direct Wired LON Network

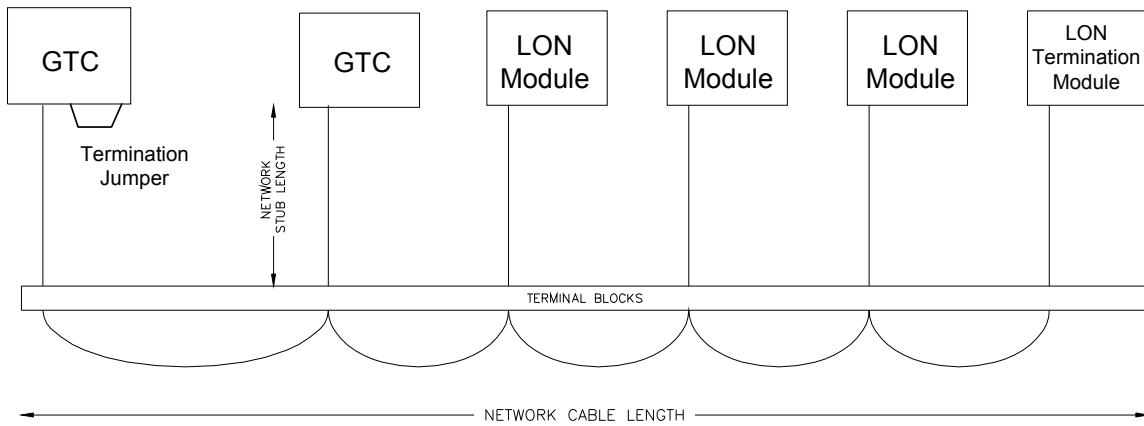

Figure 4-13. Stub Wired LON Network

It should be noted that in some installations there may be a combination of systems that may or may not be able to communicate via the Woodward product LON network. In those cases the user can opt to use a Woodward Load Sharing Interface Module (**LSIM – p/n 8239-082**). This device provides an analog to LON communication gateway which allows analog load sharing units to join a LON type of load sharing network. This device is self-configuring and self-binding but does have some limitations in that it only supports load sharing between the units. It does not support VAR/PF control through the LON.

# Chapter 5.

## Control Signal Wiring

### Introduction

A detailed list of the AtlasPC™ I/O signal layout including channel allocation, wiring terminations, descriptions, and range information is found in Appendix A. This chapter describes details of the signals that the GTC190 is programmed to handle. The control wiring diagrams in Appendix A also identify which signals are required and which are optional. The details below show the '**Programmed Default**' functions of the GTC190 input/output channels. This section should be used in conjunction with Appendix E which lists the information that the user will see on the Service and Configure screens when using Watch Window to configure the control. Appendix E will guide the user in the specific detailed configuration options of the control for each turbine. Most of the I/O channels in the GTC190 have been programmed with 3 options:

- GTC Used - as per default allocation below and in Appendix A
- Customer Use – custom signals for pre-programmed options
- Not Used

### Fuel Control Input/Output Signals

#### SmartCore Board Wiring Pinout

The SmartCore board (**SCM or MAIN**) contains circuitry for the two speed sensor inputs, six analog inputs, six analog outputs, 3 serial ports, and 24 discrete inputs. The speed sensor input is from a magnetic pick-up, each Analog input may be 4–20 mA or 0–5 V, and two of the serial ports, may be RS-232, RS-422, or RS-485. The other serial port is a dedicated RS-232 port.

#### Features

- On-board processor for automatic calibration of the I/O channels
- Analog inputs have 14-bit resolution
- Analog outputs have 12-bit resolution
- Actuator outputs have 12-bit resolution
- Serial Ports are configurable

### MPU (Speed) Inputs

The GTC190 accepts passive magnetic pickup (MPU) inputs for speed sensing. It is not recommended that gears mounted on an auxiliary shaft be used to sense speed. Auxiliary shafts tend to turn more slowly than the rotor or crankshaft (reducing speed sensing resolution) and have coupling gear backlash, resulting in less than optimum speed detection. For safety purposes, it is also not recommended that the speed sensing device sense speed from a gear coupled to a generator or mechanical drive side of a system.

Input frequency	100–24 950 Hz
Input amplitude	1–25 Vrms
Input impedance	2 k $\Omega$
Isolation voltage	500 Vac minimum, each channel is isolated from all other channels
Resolution	Dependent on frequency, 13 bit minimum at maximum speed
Accuracy	Better than $\pm 0.08\%$ full scale from $-40$ to $+85$ °C internal temperature

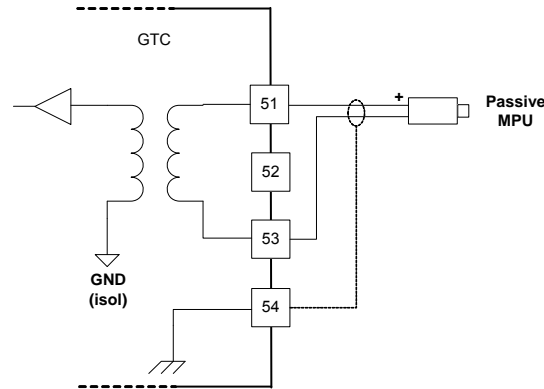

Figure 5-1. MPU Wiring Diagram

## Speed Sensing (DSS\_01 through DSS\_06)

The function of speed sensing is to monitor turbine speed. The sub-functions are:

- Speed Sensors
- Speed Derivative
- Sensor Fault Detection
- Speed Switches

### Speed Sensors

There are up to 4 speed sensors in this system for sensing the PT shaft speed. One to four can be used. There are 2 additional speed input channels that are available for the customer to use. The digital speed sensor I/O board receives input from the speed sensors on the turbine and converts this speed signal to a usable form for the control. The two speed signals are high signal selected with only the one indicating the higher speed being sent to the control PID.

### Speed Derivative

The speed sensor input blocks also generate a derivative of the speed, which gives the control a high frequency calculation of the rate of change in speed over time. This signal is high signal selected, and this value is used to control acceleration and deceleration of the turbine.

### Sensor Fault Detection

Sensor fault detection is done in the application software. On detection of a sensor fault, a signal is generated for activation of associated indicators and alarms. Failure of both PT signals will cause a shutdown. An alarm also exists for annunciating a speed difference between redundant sensors.



### Speed Switches

In the software there are three speed switches for PT. These speed switches are configurable for any speed and can be used to drive relay outputs. These outputs can be used by other systems. There is also an overspeed switch for PT which will trigger a Shutdown. Each of these switches can be configured to activate at any speed.

## Analog Inputs

The Analog Inputs may be current or voltage type. If a current input is used, a jumper is installed at the terminal block, and the software must be selected for current. This allows the GTC190 to use the applicable hardware calibration values. If a voltage input is needed, the jumper must be removed, and the software must be selected for voltage.

When the GTC190 inputs are configured (see Operator Manual), the engineering unit values are entered for the sensor at minimum (1 v or 4 mA) and at maximum (5 V or 20 mA).

The Analog Inputs may be used with a two-wire ungrounded (loop powered) transducer or isolated (self-powered) transducer. See transducer wiring below for typical wiring. If interfacing to a non-isolated device that may have the potential of reaching over 10 Vdc with respect to the control's common, the use of a loop isolator is recommended to break any return current paths, which could produce erroneous readings. Loop power must be provided from an external source.

Input type	4–20 mA or 1–5 V
Max. Input current	25 mA $\pm 5\%$ if configured for 4–20 mA
Max. Input voltage	5.0 V $\pm 5\%$ if configured for 1–5 V
Common mode rejection	80 dB minimum
Input common mode range	$\pm 11$ V minimum
Safe input common mode volt	$\pm 40$ V minimum
Input impedance	200 $\Omega$ ( $\pm 1\%$ ) if configured for 4–20 mA >260 k $\Omega$ if configured for 1–5 V
Anti-aliasing filter	2 poles at 10 ms
Resolution	14 bits
Accuracy @ 25 °C	Better than $\pm 0.1\%$ of full scale, 0.025 mA
Temp Drift	171 ppm/ $^{\circ}$ C, maximum (1.1% of full scale, 0.275 mA) 30 ppm/ $^{\circ}$ C, typical (0.20% of full scale, 0.05 mA)

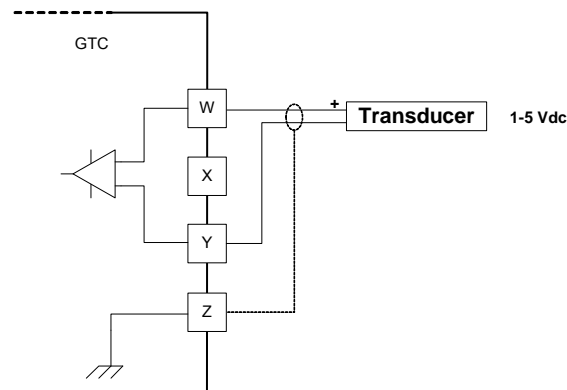

Figure 5-2. Analog Input Wiring Diagram, 1–5 V

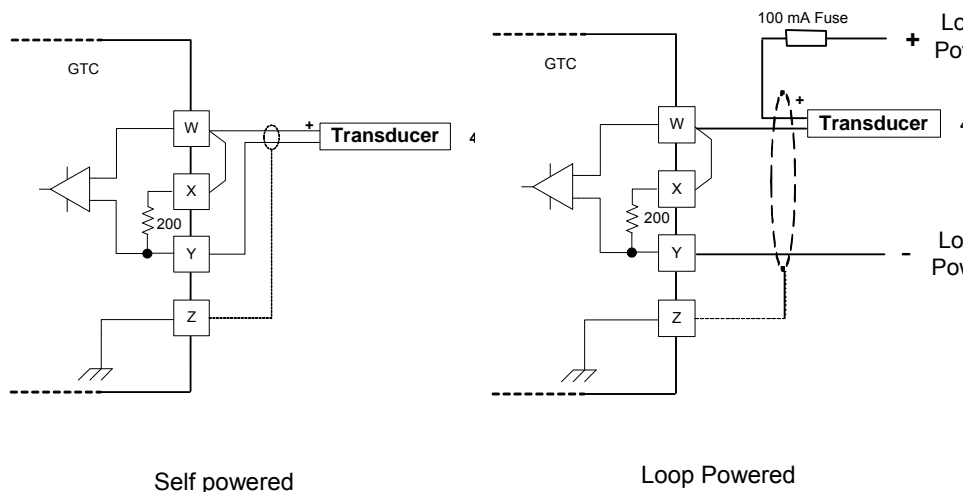

Figure 5-3. Analog Input Wiring Diagram; 4–20 mA

## Analog Inputs (AI\_01 through AI\_16)

The analog input signals in the GTC190 application are allocated in the following way:

- 16 Analog 4–20 mA inputs (first 6 of which can also be configured for 0–5 Vdc)
- 12 PT and CT Inputs—three each for the Generator & Utility Bus

Each channel can be used for a pre-programmed GTC function or they can be configured to handle customer-defined inputs. If the input is used for a customer-defined signal the control has built in options for:

1. Annunciation of a failed signal as an Alarm or a Shutdown
2. The setting of a signal level that triggers an 'event' (ALM or SD)
3. Monitoring of the signal and output of the value via Modbus

The user also has the ability to access these inputs from MultiProg and perform and logic functions that are required.

## Process Control Input Sensor – (Option Chan#01)

The process input signal is available for applications that plan to use the turbine load capability to control a plant determined parameter. The control can be setup to control this value to a programmed setpoint. The GTC will then use its output to determine the turbine load setpoint.

## Remote Speed Reference - (Option Chan #02)

The speed reference produces the desired speed-setting signal and sends it to the speed controller. The sub-functions are:

- Speed Setting
- Remote Speed Setting (PT only)

**Speed Setting**

The speed setting is raised or lowered by closing the associated contact or by commands through the Modbus communication link. The rate at which the reference changes can also be selected. The speed reference has both an upper and a lower limit position. The speed setting at each of these positions is a tunable value. The speed reference also includes relay options to indicate when that speed reference is at the lower limit.

**Remote Speed Setting**

The speed setting can be controlled by a remote signal. The ENABLE contact enables remote speed setting, as long as the speed is above rated speed. When enabled, the speed setting can be changed by varying a remote 4-to-20 mA signal. At this time all PT associated switch contacts (RAISE, LOWER, FAST, and INSTANT) will be disabled.

**Remote Process Reference Setpoint - (Option Chan#03)**

A remote Process reference setpoint can be brought back into the control via a 4-to-20 mA signal. This value is used as the setpoint for the Process controller.

**Ambient Temperature Sensor - (Option Chan#04)**

The control is designed to receive an ambient temperature signal via a single 4–20 mA input, a thermocouple input, or via an RTD input.

It is very common for this ambient temperature to be sensed by an AD590. There is an optional kit item that can be included with the GTC products to convert this signal. The AD590 microamp signal is converted to a milliamp signal through the Moore Industries device. This device has been programmed with a microamp-to-milliamp/temperature conversion chart that converts the value into a 4–20 mA signal.

The ambient temperature sensor signal is converted to a digital signal in the AtlasPC Digital Control System and can be configured to bias the EGT temperature reference and the Acceleration limiter curve. If the ambient temperature input signal fails, a fixed-value signal (tunable) is used as the bias signal.

**Remote VAR/PF Reference - (Option Chan#05)**

For units that include the PowerSense module, a remote VAR or PF reference setpoint can be brought back into the control via a 4-to-20 mA signal. This value is used as the setpoint for the Reactive Load controller.

**Exhaust Gas Temperature – EGT (Option Chan#06)**

The EGT section of this control includes the following sub-sections:

- EGT Sensing
- Temperature Reference
- Temperature Switch Output Relay Signals

**EGT Sensing**

This input is programmed to receive a single 4–20 mA input that senses the EGT if T/C input signals are not brought directly into the control. The system feeds the temperature information from this signal to the three temperature switches, the overtemp switch, and the EGT control PID.

**Temperature Reference**

The EGT Reference is set by a tunable variable and can be configured to use an ambient temperature bias. There is an option to use the EGT control for starting the unit.

**Temperature Switches**

In the software there are three temperature switches for the EGT. These temp switches are configurable for any temperature setpoint and can be used to drive relay outputs. These outputs can be used by other systems.

**Compressor Discharge Pressure – CDP or PCD (Option Chan#07)**

The compressor discharge pressure (CDP or PCD) is sensed by a 4-to-20 mA pressure transducer. This value is then used by the control for pressure control and/or as a forcing function for some of the fuel limiting schedules.

**Remote MW Reference - (Option Chan#08)**

A remote MW reference setpoint can be brought back into the control via a 4-to-20 mA signal. This value is used as the setpoint for the MW Load controller.

**P1 Gas Pressure Sensor - (Option Chan#09)**

This input is available to bring in the inlet gas fuel supply pressure at P1, the upstream or inlet side of the gas fuel metering valve.

**P2 Gas Pressure Sensor A/B - (Option Chan#10 and #11)**

These inputs are available to bring in redundant signals of the gas fuel pressure at P2, the downstream or outlet side of the gas fuel metering valve. Either one of both can be used and the user can configure how to choose between these sensors when a difference exists.

**Compressor Discharge Pressure – CDP or PCD (Option Chan#12)**

This channel is available as a redundant compressor discharge pressure (CDP or PCD) signal transducer. The selected value of these 2 signals is configured by the user, and this value is then used by the control for pressure control and/or as a forcing function for some of the fuel limiting schedules.

## Analog Flame Detector Signals - (Option Chan#13,14,15,16)

The GTC is design to receive either discrete input or analog flame detector signals. If the analog signals are used they are connected to these channels. One, two, three or four can be used and they are needed to verify that a healthy flame exists inside of the turbine combustor. This signal is used to detect 'light-off' of the turbine during the start and ignition sequence and it is also used as a potential shutdown (loss of flame) condition.

## Customer Defined Signal - (On any unused channels)

The customer can bring in a 4-20 mA signal for any site specific parameter that they desire. The GTC application is designed to allow a configurable switch to be activated by this input value. This event action can be configured as an Alarm or a Shutdown. The user can configure the loss of this input signal to trigger either an Alarm or a Shutdown.

## Discrete Inputs

There are 24 discrete inputs which are all individually optically isolated; however, all 24 share a common power supply return. The inputs expect 24 Vdc for an asserted state.

Number of channels	24
Input type	Optically isolated discrete input
Input thresholds	< 8 Vdc = "OFF" > 16 Vdc = "ON"
Input current	3 mA @ 24 Vdc
Contact voltage	24 Vdc isolated
Max input voltage	28 Vdc
Isolation voltage	500 Vac, all channels are isolated from the other I/O

An external 18–28 Vdc power source can be used to source the circuit wetting voltage for the discrete inputs. Due to circuit isolation, the external power supply common must be connected to the GTC190 terminal 25 as shown in the wiring diagrams in Appendix A. However, for EMC Compliance, the on board, isolated, +24 Vdc supply is recommended for use as the contact wetting voltage. The internal supply should only be used for the discrete inputs as shown in the diagrams; use in other, unrelated, circuits could overload the supply or create ground loops. The internal, isolated, supply is limited to approximately 300 mA maximum.

## Discrete Inputs (BI\_01 thru BI\_24)

These twenty-four discrete inputs are available as direct inputs into the AtlasPC I/O. These 'high-speed' input signals are used to direct the actions and functions of the fuel control. The first 3 inputs are fixed and can only be used for the function shown. All other inputs (4-24) are configurable to be used for the function shown or to be used for custom signals. If the discrete inputs is used for a custom signal, the have been pre-programmed with the following optional functionality:

1. A Start Permissive Input
2. An Alarm Condition Input
3. An Shutdown Condition Input

The default function and active state of each of these signals is shown, these can be altered in the configuration of the control. The signal status of each input will be sent through the Modbus communication link as indications.

<b>GTC Function</b>	<b>Active State</b>
1. Shutdown (Fuel Off)	* TRUE = Shutdown / Fuel OFF
2. Start/Run (ON to Run) Stop)	* TRUE = Start / Fuel ON, (False = Normal
3. System Reset (ALM & SD)	* TRUE = Reset Alarm/Shutdown
4. System Acknowledge (ALM & SD)	TRUE = Acknowledge Alarm/Shutdown
5. PT Reference Lower	TRUE = Lower PT Speed Setpoint
6. Speed Reference Raise	TRUE = Raises PT Speed Setpoint
7. Speed Reference Select Fast Rate	TRUE = PT Speed Setpoint Rate = Fast
8. Speed Signal Failed Override	TRUE = Override PT sensor failure (to Start)
9. Set PT Reference to Rated Speed	TRUE = PT Ref is set to Rated Speed
10. Enable Process Control	TRUE = Enable Process Control
11. Enable Reactive Load Control	TRUE = Enables unit VAR/PF Control
12. Enable Remote PT Reference Setpoint	TRUE = Actively follow remote setpoint
13. Inhibit Synchronizer	TRUE = Disable Synchronization logic
14. Generator Breaker Aux (52)	TRUE = Generator Breaker CLOSED
15. Utility Breaker Open for LS)	TRUE = Utility Breaker OPEN (Permissive
16. Fuel Selection/Transfer	TRUE = Liquid Fuel (False = Gas Fuel)
17. Voltage/VAR/PF Lower Command	TRUE = Lower the Reactive Load setpoint
18. Voltage/VAR/PF Raise Command	TRUE = Raise the Reactive Load setpoint
19. Process Setpoint Lower Command	TRUE = Lower the Process setpoint
20. Process Setpoint Raise Command	TRUE = Raise the Process setpoint
21. Combustor Flame Detector A	TRUE = Flame Detected
22. Combustor Flame Detector B	TRUE = Flame Detected
23. Combustor Flame Detector C	TRUE = Flame Detected
24. Combustor Flame Detector D	TRUE = Flame Detected

## Discrete Outputs

There are 12 discrete output relay drivers, which are individually optically isolated, available from the AtlasPC I/O. However, all twelve share a common power supply and return circuit. Each output uses a thermally protected MOSFET that will pulse the circuit if the current limit is exceeded. An over-current condition on one output will not affect the other outputs. The output will be pulsed continuously until the current requirement is reduced, allowing the output to operate normally again.

Number of channels	12
Output type	Low-side driver with short circuit and over voltage protection
Current drive rating	<200 mA
Discrete Output supply voltage	9-32 Vdc
Isolation voltage	500 Vac, all channels are isolated from the other I/O

An external 9–32 Vdc power source must be provided to source the circuit voltage switched by the GTC190. Due to circuit isolation, the external power supply common must be connected to the GTC190 terminal 23 as shown in the wiring diagrams in Appendix A.

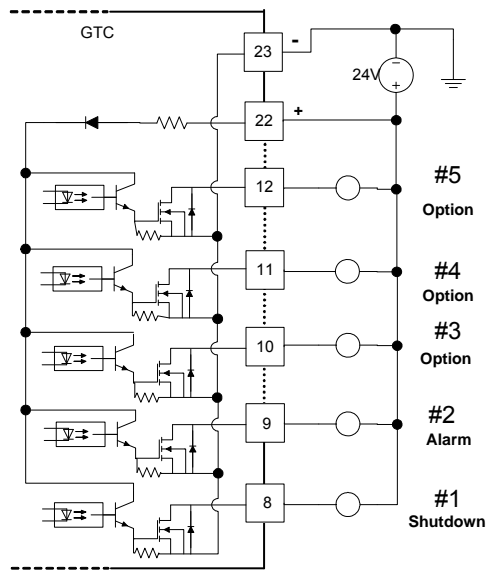

Figure 5-4. Discrete Output Wiring Diagram

## Relay Driver Outputs

Twelve relay driver outputs are available from the GTC190 application. These signals are used to indicate the function or status of the control or turbine. The first two relay outputs are for SHUTDOWN and ALARM and fixed outputs. The SHUTDOWN signal (1) is normally energized to reflect a healthy GTC190 with no shutdowns present. The ALARM signal (2) along with all of the others is normally de-energized, and the control energizes this output on one of 2 configurable conditions: 1) Alarm summary – meaning that the output is true when any alarm is present or 2) Alarm Horn indication – meaning that when an Alarm event comes in, the output is True until an Acknowledge input is received, then the output goes False until another alarm condition happens. The other ten signal outputs are configurable via a menu (as per the list below) for each relay output to be driven from a pre-programmed function in the fuel control, or to be driven via a Modbus or MultiProg command..

### **IMPORTANT**

When configuring these output drivers, use these relays for the most critical (time dependent) signals, such as fuel shutoff valve commands. These channels are all programmed to be updated a recursion rate of 10 ms.

- 1) SHUTDOWN
- 2) ALARM
- 3) EGT Temp Switch 1
- 4) EGT Temp Switch 2
- 5) EGT Temp Switch 3
- 6) PT Speed Switch 1
- 7) PT Speed Switch 2
- 8) PT Speed Switch 3
- 9) PT Speed Reference at Lower Limit
- 10) Open Breaker Command
- 11) Close Breaker Command
- 12) Raise Voltage Command to AVR
- 13) Lower Voltage Command to AVR
- 14) Speed in Control

- 15) EGT in Control
- 16) EGT Derivative in Control
- 17) Process Control Enabled
- 18) Load Sharing Enabled
- 19) HP Compressor Bleed Valve Command
- 20) LP Compressor Bleed Valve Command
- 21) Liquid Fuel Selected (off = On Gas Fuel)
- 22) Motor Starter Engaged
- 23) Turning / Ratchet Gear ON
- 24) Ignitors Energized (ON)
- 25) Open Gas Fuel Shutoff Valves
- 26) Open Liquid Fuel Shutoff Valves
- 27) Remote Fuel Driver Reset Command
- 28) Customer Command from Modbus BW 21
- 29) Customer Command from Modbus BW 22
- 30) Customer Command from Modbus BW 23
- 31) Customer Command from Modbus BW 24
- 32) \*FALSE (Access for MP to control this output)

### Actuator Driver Outputs (ACT\_01 and ACT\_02)

This system includes two actuator drivers, one for the gaseous-fuel actuator (ACT\_01) and one for the liquid-fuel actuator (ACT\_02). Each of the actuator drivers receives a fuel demand signal and sends a proportional drive current signal to its actuator. Each actuator, in turn, controls the flow of one type of fuel. The outputs are configurable as 4–20 mA or 0–200 mA. These outputs are proportional drivers only—if integrating drivers are required, use the Woodward Servo Position Controllers (SPC) that can be connected to the GTC via a DeviceNet communication link.

Number of channels	2
Actuator Type	Proportional, non-isolated
Output type	4–20 or 20–160 mA outputs, software selectable
Common Mode Voltage	15 Vdc $\pm$ 10%
Max current output	25 mA $\pm$ 5% (4–20 mA scale) 200 mA $\pm$ 5% (20–160 mA scale)
Min. load resistance	0 $\Omega$
Max load resistance	300 $\Omega$ at 22 mA (4–20 mA scale) 45 $\Omega$ at 200 mA (20–160 mA scale)
Resolution	12 bits
Accuracy @ 25 °C	Better than $\pm$ 0.1% of full scale 0.026mA (4–20 mA scale) 0.2mA (20–160 mA scale)
Readback Accuracy @ 25 °C	0.5%
Temperature Drift	140 ppm/°C, 0.24 mA maximum (4–20 mA scale) 1.82 mA maximum (20–160 mA scale) 70 ppm/°C, typical (0.45% of full scale, 0.11375 mA) 0.12 mA maximum (4–20 mA scale) 0.91 mA maximum (20–160 mA scale)
Readbacks	Actuator source and return currents
Dither Current	25 Hz, fixed duty cycle, software variable amplitude



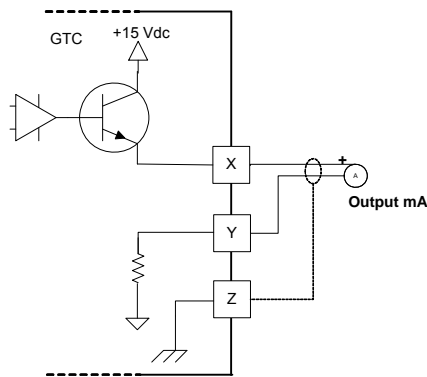

Figure 5-5. Actuator Output Wiring Diagram

### Gas Fuel Valve Position Demand (ACT\_01, SPC\_01, GSV\_01)

The gas fuel valve position demand is output from the control via this actuator output channel and via the DeviceNet connection to SPC, and directly to a GS series valve. The actuator output can be a 4-20 mA or 20-160 mA signal from the control to the valve driver or to the valve itself. The output block for the SPC will be defined in the GAP as FB\_EQUIP # 1 (Fieldbus Equipment Number) and the SPC for the gas metering valve must be configured with a MAC ID # 1. The GSV will be defined in the GAP as FB\_EQUIP # 5 (Fieldbus Equipment Number) and the GSV for the gas metering valve must be configured with a MAC ID # 5.

### Liquid Fuel Valve Position Demand (ACT\_02, SPC\_02)

The liquid fuel valve position demand is output from the control via this actuator output channel and via the DeviceNet connection to an SPC. The actuator output can be a 4-20 mA or 20-160 mA signal from the control to the valve driver or to the valve itself. The output block for the SPC will be defined in the GAP as FB\_EQUIP # 2 (Fieldbus Equipment Number) and the SPC for the liquid metering valve must be configured with a MAC ID # 2.

## Analog Outputs

There are ten analog outputs that may be assigned to a number of functions. Each output is a 4–20 mA current source. The Analog Outputs may be used with a two-wire ungrounded device or isolated device. If interfacing to a non-isolated device, the use of a loop isolator is required. The chart below give the parameters that may be configured for analog output, The scale or range of each parameter can also be changed, i.e. a frequency read out may be set for 57 to 63 Hz, or 30 to 65 Hz.

Number of channels	6, PWM outputs
Output type	4–20 mA outputs, non-isolated
PWM frequency	1.5 kHz
Common Mode Voltage	15 Vdc $\pm$ 10%
Current output	4–20 mA
Max current output	25 mA $\pm$ 5%
Min. load resistance	0 $\Omega$
Max load resistance	300 $\Omega$ at 22 mA
Resolution	12 bits
Accuracy @ 25 °C	Better than $\pm$ 0.1% of full scale, 0.025 mA
Temperature Drift	140 ppm/ $^{\circ}$ C, 0.23 mA maximum 70 ppm/ $^{\circ}$ C, typical (0.45% of full scale, 0.11375 mA)

Each analog output has identical circuitry. There is no isolation between outputs and no isolation to the digital circuitry of the GTC190. Wiring for each is shown below but only the terminal numbers change for each output.

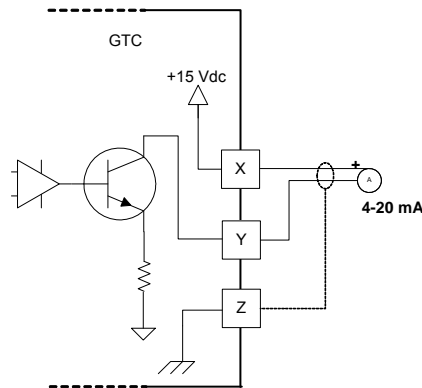

Figure 5-6. Analog Output Wiring Diagram

### Analog Outputs (AO\_01 thru AO\_10)

The system includes ten analog outputs. These readout signals are 4–20 mA signals for driving meters or sending readouts to other plant system controls. Each of these signals is configurable in the application program.

1. Actual Speed Readout
2. Speed Reference Readout
3. Exhaust Gas Temperature Readout
4. Gas Fuel Valve Demand
5. Liquid Fuel Valve Demand
6. Generator MW Sensor Readout
7. Generator MegaVar Output Readout
8. Generator MegaVoltAmp Output Readout
9. Generator Power Factor Output Readout
10. Generator Current
11. Generator Voltage
12. Utility Bus MW Sensor Readout
13. Utility Bus MegaVar Output Readout
14. Utility Bus MegaVoltAmp Output Readout
15. Utility Bus Power Factor Output Readout
16. Utility Bus Current
17. Utility Bus Voltage
18. Synchroscope Output
19. Customer Configurable Analog Output (from Modbus AW\_14)
20. Customer Configurable Analog Output (from Modbus AW\_15)

21. Customer Configurable Analog Output (from Modbus AW\_16)
22. Customer Configurable Analog Output (from Modbus AW\_17)
23. Speed / Ratio Valve Demand Output
24. \*0-100 (Access for MP to control this output)

\*Via the Watch Window service tool it is possible to select the output of the power monitoring elements to be displayed as a phase value, or total/average of the phases. The default is to output the total/average.

## Communication Ports

There are three serial ports on the GTC190. They may all be used simultaneously and may all be configured independently. Performance of any one port will depend on how many ports are in use and the port traffic. Ports 1 and 2 may be configured as RS-232, RS-422, or RS-485 to match the intended application. All ports are optically isolated from each other.

Any port configured as RS-232 will meet the RS-232C standard for communications. The wiring shall meet the requirements of EIA RS-232. This standard states a maximum cable length of 15 m (50 ft) with a total capacitance less than 2500 pF and a data rate not exceeding 56 kbps. All GTC190 serial ports may be configured for data rates up to 115 200 bps but may not function properly at this high data rate when a full 15 meters of cable length is used. Do not leave an RS-232 null modem cable attached to the GTC190 if it is removed from the PC, to avoid the possibility of EMC noise being introduced to the GTC190.

Any port configured as RS-422 or RS-485 meets the ANSI standards for this type of communications. The wiring shall be one continuous cable between nodes and shall meet the requirements of EIA RS-422 or EIA RS-485 for 500 kbps. However, one half of the cable length limits is recommended due to harsh environments typical of prime mover installations as follows:

Cable	Length	Example
Standard shielded twisted pair cable	30 m (100 ft)	
24 AWG, low-capacitance cable	75 m (250 ft)	Belden 9841
22 AWG, low-capacitance cable	120 m (400 ft)	Belden 3105A
20 AWG, low-capacitance cable	150 m (500 ft)	Belden 89207
Fiber optic cable with optical repeaters	> 150 m (500 ft)	

The last unit in the network chain, and only the last unit, should have its receiver terminated with a resistor. If the GTC190 is the last unit, installing jumpers as shown on the following diagrams may use the internal resistors

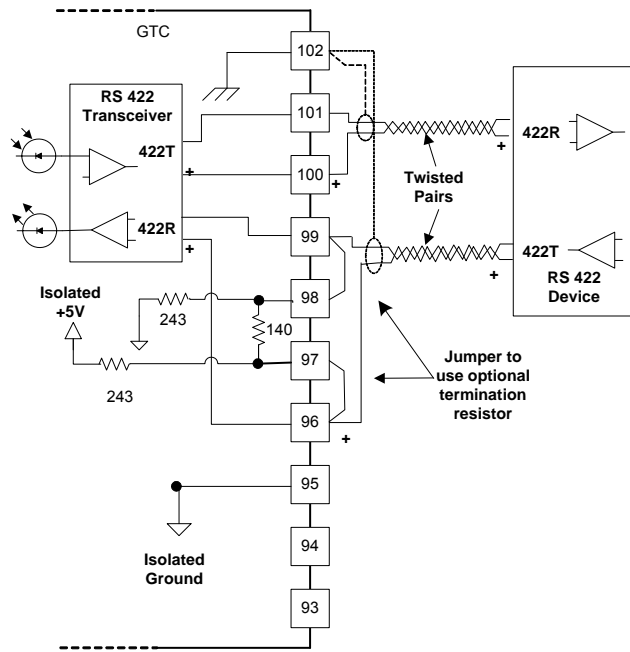

Figure 5-7 Serial 1 Wiring Diagrams, RS-422

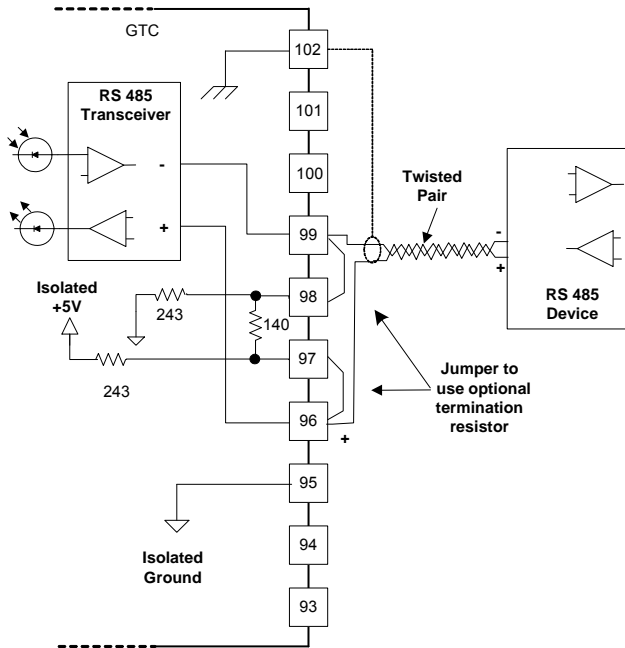

Figure 5-8 Serial 1 Wiring Diagrams, RS-485

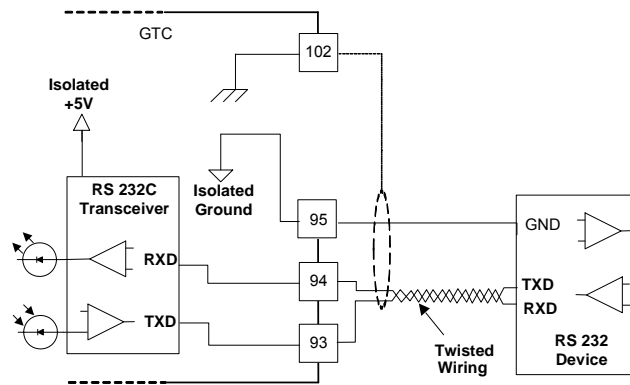

Figure 5-9 Serial 1 Wiring Diagrams, RS-232

### Configurable Port (COM 1)

This port may be configured to use Modbus protocol and communicate as a Modbus Slave with any other plant device (typically an Operator Interface or a plant DCS system). A list of the Modbus data that is programmed in the GTC190 application can be found in Appendix B.

This port configuration is defaulted as an RS-485 port, with a baud rate of 38.4 kbps, no parity, 8 data bits, and 1 stop bit.

### Configurable Port (COM 2)

The port may be configured for RS-232, RS-422, or RS-485 by using the correct wiring connections and selecting the correct protocol mode.

This port may be configured to use Modbus protocol and communicate as a Modbus Slave with any other plant device (typically an Operator Interface or a plant DCS system). A list of the Modbus data that is programmed in the GTC190 application can be found in Appendix B.

This port configuration is defaulted as an RS-232 port, with a baud rate of 38.4 kbps, no parity, 8 data bits, and 1 stop bit.

### RS-232 Configuration Port (COM 3)

This port may only be used as a Woodward ServLink port. Its primary purpose is for configuration using a PC with Woodward's Watch Window.

The port is fixed as an RS-232 port only. The RS-232 port configuration is defaulted at 115200 bps, no parity, 8 data bits, and 1 stop bit. A Null Modem cable must be used to connect to this port. The GTC190 has a standard DB-9 Female receptacle. It is best to use a metal shell connector at both ends with the shell connected to the cable shield but isolated from the ground signal wire. The shell of the 9-pin D-sub on the GTC190 is chassis grounded.

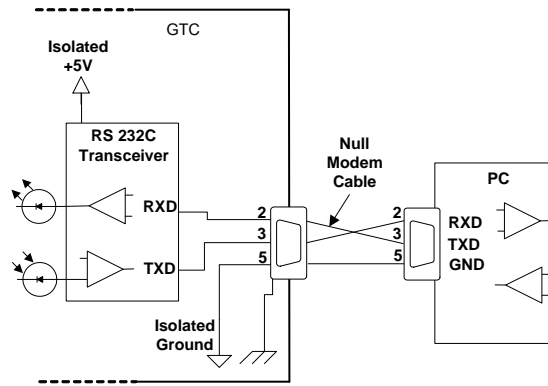

Figure 5-10. Serial 3 Wiring Diagram, RS-232

## Software Interface Tools Setup

### Watch Window Standard (WWI)

The WWI tool permits you to talk to the AtlasPC Digital Control System via a serial port on the AtlasPC SmartCore module. It limits the users view into the control system by only allowing them to see the blocks programmed into the Service and Configure modes. This tool is free-issue from Woodward and exists on the system documentation CD or is available from the [woodward.com](http://woodward.com) website.

### Watch Window Professional (WWPro)

The WWPro tool permits you to talk to the AtlasPC Digital Control System via a serial port on the AtlasPC SmartCore module. It allows the users to view all of the application program blocks that exist in the control system.

### Watch Window Program (Both Standard and Professional)

Use of one of the WW tools (Standard or Professional) is required to access the application software tunable values of the AtlasPC Digital Control System. Software setup for the GTC190 begins with the Software Configuration & Service Tunables Worksheet. When the worksheet is completed, the values are then entered into the GTC190 with the WW tool. This tool can also be used to upload (from the control to a file on the user PC) the tunable settings from the control. This file then can be downloaded (from the user PC to the control) into another control of the same part number and revision number. Keep this tunable file archived, as it will simplify configuration of other spare units and aid technical support in commissioning and troubleshooting.

WWI runs on a PC connected to the control system through a serial communications port. The PC may be permanently connected to the control or connected only as needed. The communications server, ServLink I/O Server, is included in the same CD-ROM with the Watch Window software.

An “inspector” provides a window for real-time monitoring and editing of all control Configuration and Service Menu parameters and values. Custom “inspectors” can easily be created and saved (WWPro only). Each window can display up to 28 lines of monitoring and tuning parameters without scrolling. The number with scrolling is unlimited. Two windows can be open simultaneously to display up to 56 parameters without scrolling. Tunable values can be adjusted at the inspector window. Watch Window communicates with the control through an RS-232 cable connection to the comm port configured as a point-to-point only ServLink Server.

Watch Window is a typical Windows application that provides a powerful and intuitive interface. The menu structures are familiar to Windows users. Variable navigation is provided through the Explorer window similar to the Explorer in Windows.

Watch Window performs these primary functions:

**Monitoring and Tuning of Control Variables**—Watch Window presents variables in a tabular format. The user chooses the variables to view. Multiple pages of variables can be created, each with useful parameters for various troubleshooting or tuning procedures. The user can toggle between pages depending on the task being performed.

**Control Configuration and Set Point Management**—Watch Window can upload or download all tunable variables from the control system. This feature allows a user (e.g., fleet owner, distributor, packager) to upload (and save) all tunable parameters from one control and download the same settings to other controls for similar turbine configurations.



Watch Window version 1.05 and higher, allows for automatic generation of inspector sheets. Click on the Q icon (Quick Inspector) on the tool bar. A sheet will automatically be created from each Service and Configure Header programmed into the control. Multiple inspectors can be created to allow for viewing more than one sheet at a time.



To enter the I/O Lock mode and enable a configure value to be entered, click on the I/O Lock icon on the Tool Bar. Because the values set in Configure are critical to turbine operation, it is not safe to operate the prime mover while these parameters are being configured. In the Configure mode, the control outputs will be set to their off state and the microprocessor will stop executing the application code. The control will have to be reset to continue operation.



The Reset icon allows the microprocessor to store the configure parameters, to return the outputs to their active state, and to resume executing the application software.



When the tuning or setting of parameters is complete, the values must be saved in the control’s non-volatile memory. Go to the Tool Bar and click the PROM icon for Save Values. The values will be saved in non-volatile memory and will be unaffected by loss of power to the control.



If an application configuration has been previously saved to a \*.CFG file, the saved set of parameters can be loaded into the control as a group by selecting the Load Application Settings icon.



To save the configuration to a file in the external computer for backup or download later into another control, select the Save Application Settings icon. All the tunable values presently set in the control will be saved to a file and can be loaded into this control to reprogram it to the saved values or into another control at a later time.

## Install Watch Window Software

Woodward's Watch Window Standard configuration and service tool may be downloaded at no cost from the Woodward website ([www.woodward.com/ic/software](http://www.woodward.com/ic/software)). As an alternative, a Watch Window CD Install Kit may be purchased from the nearest Woodward distributor. Once downloaded, select the kit's Setup.exe program on the computer on which you wish to install the Watch Window software program. Please refer the product specification 03202 for detailed installation procedures.

## Connect PC to GTC190

The connection of a computer is only required for calibration and setup of the GTC190. The computer and WWI software program are not required or necessary for normal operation of the control. You will need to connect a standard 9-pin Null Modem cable between the communication port # 3 (COM 3) of the AtlasPC Main (SmartCore) module on the GTC190 and a user PC. This port has a 9-pin sub-D connector and is located on the bottom layer of the PC104 bus stack of the control modules. This port's protocol settings are defaulted to the correct settings to communicate with the Woodward WWI service tool (Baud = 115200, Data Bits = 8, Stop Bits = 1, Parity = None). For information on the cable or communication port settings, see the troubleshooting section of this manual.

## Apply Power to the GTC190

At power-up, the GTC190 runs through its boot-up routine and performs a set of initial diagnostics to verify CPU, memory, I/O initialization, and bus health. This boot-up routine takes approximately a minute to execute. During this time, the control's red status LEDs on the CPU and I/O modules should be on. When boot-up is complete, the application program code begins running, the control outputs will be enabled, and system control will begin—the control's red status LEDs will turn off and should remain off as long as the control is running.

### Initial GTC190 Communications:

Before communications can begin between the WWI program and a control, a network definition file must be created. Once this network definition file is created and saved, it never has to be recreated, unless a new program is loaded into the control.



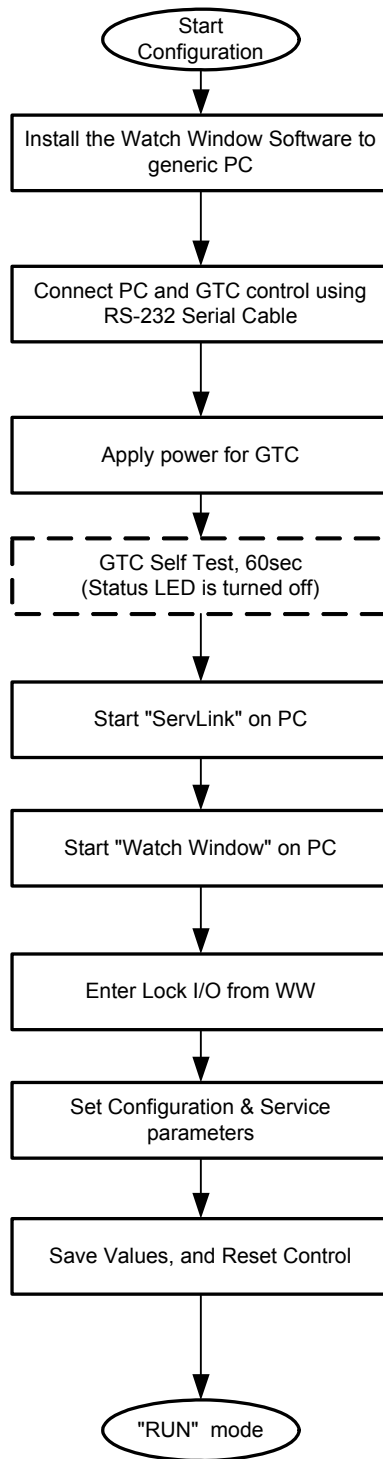

Figure 5-11. Basic Configuration Procedures

To create a network definition file:

1. Open the Watch Window program's associated ServLink server by clicking on Start > Programs > Woodward > ServLink Server.exe.
2. Select the communications port the control is connected to.
3. Select "Point-to-Point" communications.
4. Select the Baud Rate of 115200.
5. Select the OK button.

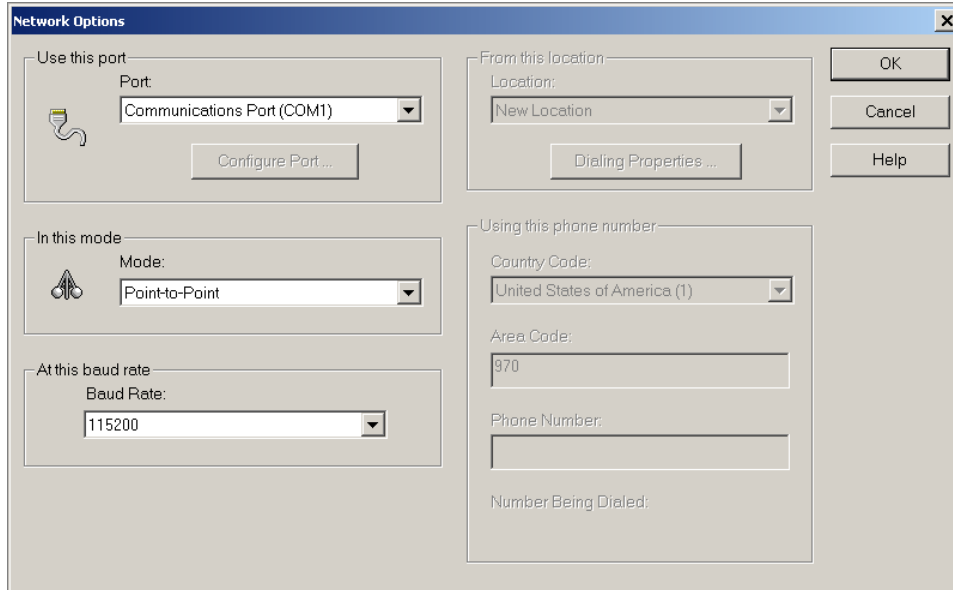

Figure 5-12. Setup ServLink Communication

At this point the ServLink Server program will establish control communications, begin reading all control setting registers, and create a lookup table for these registers to expedite future control communications. Upon reading register location information from the control, the following Windows pop-up box will appear. (This step can take several minutes to complete.)

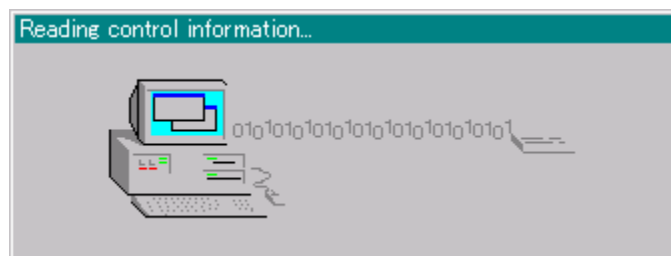



Figure 5-13. Reading Control Information

Once all control program registers have been read, the text "Dflt Control ID" will appear within the ServLink program window and the network definition file can be saved for future retrieval by the Watch Window program. If the network definition file is not saved it will have to be re-created before computer-to-control communications can be established again. Save this network definition file and minimize the ServLink program window.

## Start Watch Window Software

At this point, start the Watch Window software program by clicking on Start > Programs > Woodward > Watch Window Standard.exe.

The Watch Window Menu bar, Explorer and Inspector will appear as shown in Figure 3-4. Click on the  icon (Quick Inspector) on the tool bar. Multiple sheets will automatically be created from each Service and Configure Header programmed into the control. Refer to Figure 3-5. Optionally, other inspectors can be created to allow viewing of more than one sheet at a time.

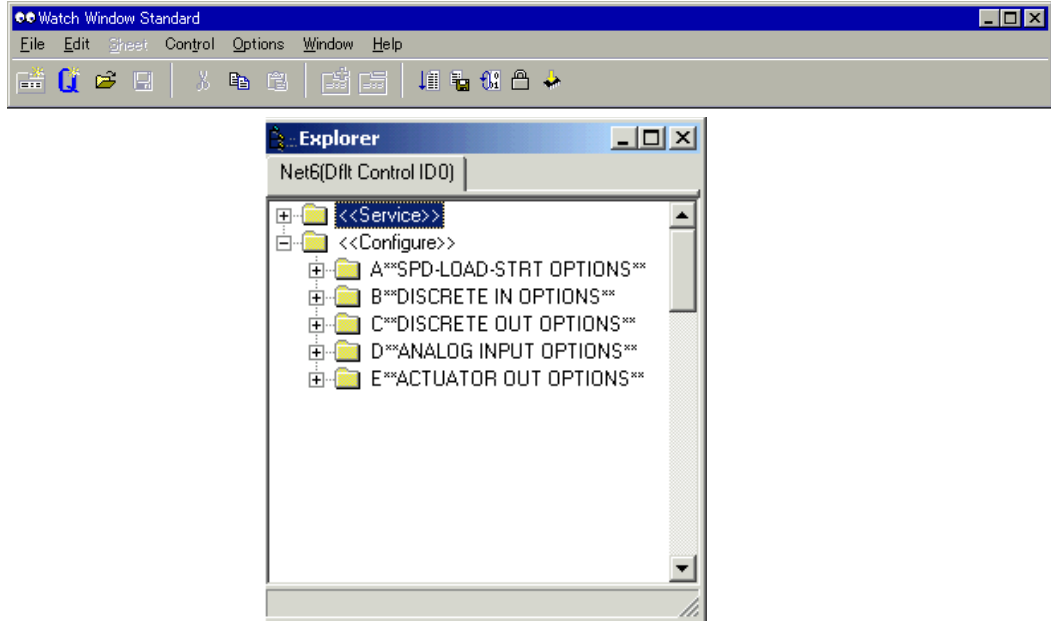



Figure 5-14. Watch Window Menu and Explorer

## Configure Menu Descriptions

The GTC190 has multiple Configure and Service menus to simplify and protect control settings and their adjustments. All menus appear as pages (or sheets), are arranged alphabetically, and can be located by using the inspector's arrow buttons located above the pages to scroll to the desired menu.

The program's Configure menu items are protected when the control is in operation and cannot be changed. Before configuration values can be changed, the control must be in its I/O Lock mode. Service menus are not protected and can be modified at any time.

To enter the I/O Lock mode and enable configure changes, click on the  I/O Lock icon on the Tool Bar. Because the values set in Configure are critical to turbine operation, it is not safe to operate the prime mover while these parameters are being configured. In the I/O Lock mode the control outputs will be set to their off state and the microprocessor will stop executing the application code.

Once the configuration changes have been completed click on the  Reset icon to allow the control to store the configured parameters, return the outputs to their active state and resume executing the application software.

**IMPORTANT**

At this point Exit the WWI program and then Power Cycle the GTC control. This will allow the unit to re-initialize the configured parameters and resume executing the application software. This is an important step, do to the interaction of the VxWorks and ProConOS operating systems. It is only required when uploading tunables or when Configuration parameters have been set. It is not required for normal saving of tunable values on the control.

## Watch Window II (WWII)

The WWII tool permits you to talk to the GTC190 via the Ethernet port on the CPU. You can use WWII to monitor values, read fault messages, or issue instructions to the GTC190 System, however you cannot access the service or configuration screens. The WWII tool runs on a laptop or desktop PC and utilizes standard Windows dialog boxes and Explorer windows to allow the user to create 'Inspector' files of any fields available in the application software. This tool should only be used by experienced users and does not automatically generate the 'Inspector' files.

## Control Assistant Software (Version 3.0 or greater)

This tool is an optional utility that can help manage tunable values, trend values within the control, and view 'datalog' files – which are high speed data files that the control creates upon chosen events. The GTC190 is programmed to interface with this tool via an Ethernet connection using Port 5001 for tunable transfers and Port 5004 for retrieving Datalogs. The latest version of this software can also be used as the main service interface tool via Ethernet. It is a purchased product that includes trending capability, tunable maintenance tools, and built-in Watch Window Professional functionality. It can be a useful troubleshooting tool for experienced users.

## Initiating Ethernet Communications with the Control

Each GTC190 ships from Woodward with a default IP address of 190.14.99.220. This means that the user must initially connect directly to the control with a PC that has had its IP changed to an address that is on this same first three octets within the subnet mask (for example 190.14.99.221). Once the connecting PC is configured like this, the user can launch WWII by typing the IP address in the initial dialog box that opens when WWII is launched.

## Changing the IP address of the Control

It is usually desirable to change the fixed IP to an address available on the user's plant network, thus placing the control on the plant LAN. This is done via the AppManager program (available from [www.woodward.com](http://www.woodward.com)). The user can change the control IP to any available IP on the plants local network. The GTC190 can also be setup to receive an IP automatically from a DNS or DHCP on the customer network.

**IMPORTANT**

This is done from AppManager via the Control header in the tool bar and selecting "Change Network Settings" under the pull down menu.

# Chapter 6.

## Control Functionality Setup Procedures

### Introduction

This chapter contains information on control configurations, setting adjustments, and the use of Woodward's Watch Window software tool. Because of the variety of installations, system and component tolerances, the GTC190 must be tuned and configured for each system to obtain safe operation and optimum performance.



#### **WARNING**

**An improperly calibrated control could cause an overspeed or other damage to the prime mover. To prevent possible serious injury from an overspeeding prime mover, read this entire procedure before starting the prime mover.**

The worksheet in the Appendices of this manual should be used to select the values used in the tunable blocks of the GAP™ program for the GTC190 application. On the lines provided, enter the values used for your control. Once the worksheet is completed, connect the control with the WWI tool as described in the previous section. Click on the Q in the tool bar to execute a routine that will automatically generate an inspector file for all of the configuration and service fields (***you will want to resize the Block, Field, and Value columns in the inspector file to see the complete prompts that exist for each row***). Using the worksheet, tune each field to the value you require for your application. Use a separate worksheet for each control when more than one control is used at each site. Note that as a user gets more familiar with the system, you can modify/customize your own inspector files to best fit your needs.

This should be done at initial installation to establish the correct turbine package configuration details for correct operation of the fuel control. The turbine must be shutdown (in a non-running state) during control set-up to tune or adjust any of the parameters on the Configuration sheets. This is not required to adjust or tune any parameters in the Service sheets.

### Start Modes

This control contains an option to use a standard start sequence for starting the gas turbine, which is the initial control mode for the fuel. These options are intended to provide a consistent acceleration of the turbine, from turbine 'lite-off' up to closed loop speed control. Once the fuel control has reached speed control, the start mode demand signal is ramped out of the way (to 100%). It is important to point out that the fuel control will not ramp the fuel valve open until the control recognizes that the turbine has achieved 'lite-off'. The default start option is to have the control raise the fuel demand via a start ramp at the user-defined rate until the unit reaches PT Speed control at the minimum PT reference value. This allows for the most aggressive ramp-up times of the turbine. For less aggressive ramp-ups, the start ramp rate can be reduced, or the EGT Temp controlled start ramp option can be enabled.

Once the Start / Run discrete input contact is closed (TRUE), the fuel control will initiate a start. If the GTC Start Sequence option is selected, then this input will initiate the start sequence and the fuel valve demand will rise at the appropriate time. This contact is NOT a latched input, meaning that it must be held TRUE to activate fuel (hold closed versus momentary). If this signal is lost or drops out, the fuel control enters a Normal Stop routine. If this option is not selected, then this discrete input will indicate to the control that a start has been issued, but will allow MP to handle the complete startup sequence.

To achieve successful turbine 'lite-off', the unit must first be set up for either a Mechanical Lite-off or an Electrical Lite-off.

## IMPORTANT

For information on setting correct Fuel Flow for lite-off, see the Troubleshooting section.

**Mechanical Lite-off** = Minimum Valve position mechanically set to yield correct lite-off fuel flow. If this is used configure the MIN\_FUEL position to Zero (0.0).

**Electrical Lite-off** = Minimum Valve position is set in software (MIN\_FUEL) to yield correct valve demand position to yield lite-off fuel flow. If this is used then mechanically the valve should have the min stop set to zero degrees.

### Start Ramp Control Start (Default rate 0.3 % per sec)

The initial increase of fuel valve position is accomplished by a ramp up the Start Ramp from the initial MIN\_FUEL position to a point at which a speed loop takes over control of the fuel valve demand. The ramp will increase at the default rate, which is configurable. The start ramp provides a user-defined increase in fuel valve demand and a corresponding acceleration of the turbine until another input of the LSS takes control. If the rate of increase of the ramp becomes too high, the Acceleration control or EGT Temp limiter control will take over control of fuel demand.

### EGT Temp Ramp Control Start

After the initial increase of fuel valve position is accomplished by the start ramp, the EGT PID can be used to bring the unit up to a point at which a speed loop takes over control of the fuel valve demand. The temp ramp contains two user defined setpoints and a ramp rate (in °F/s). The temp ramp starts at the Lower temp setpoint until 'Lite-off' is detected. The ramp then ramps up to the High temp setpoint at the user defined rate. This option is useful if a unit is experiencing overtemps during start-ups or the user desires to avoid high temps at sub-idle conditions.

## Auto Start/Stop Sequence

The GTC190 has a built in automatic start sequence that can be configured by the user. In addition to this auto sequence, the user has the option to use the GTC relay outputs for the Motor Starter, Ignitors, and Fuel Shutoff (Block) valves. To use these outputs they must be configured in the relay output section of the hardware.

Configuration Items:

- |  |       |
|--|-------|
| 1) Use Auto Start/Stop SEQ?              | *True |
| 2) Use Fuel SOV & Ignitor relay outputs? | *True |

The state of these two configuration items (1 and 2) will determine how the GTC will respond to a Start/Run command.

**True/True** = complete start sequence logic as shown below is followed

**True/False** = start sequence begins at “Attempt Turbine Lite-off” step, assuming the fuel block valves and ignitors are activated, and then continues as shown

**False/Neither T or F** = control will follow the “Attempt Turbine Lite-off” and “Lite-off and Accelerate to PT Idle” steps, once turbine reaches PT Idle the start sequence is completed.

The GTC190 utilizes Sequential Function blocks that define steps within the sequence. The following steps are included in the GTC190 application:

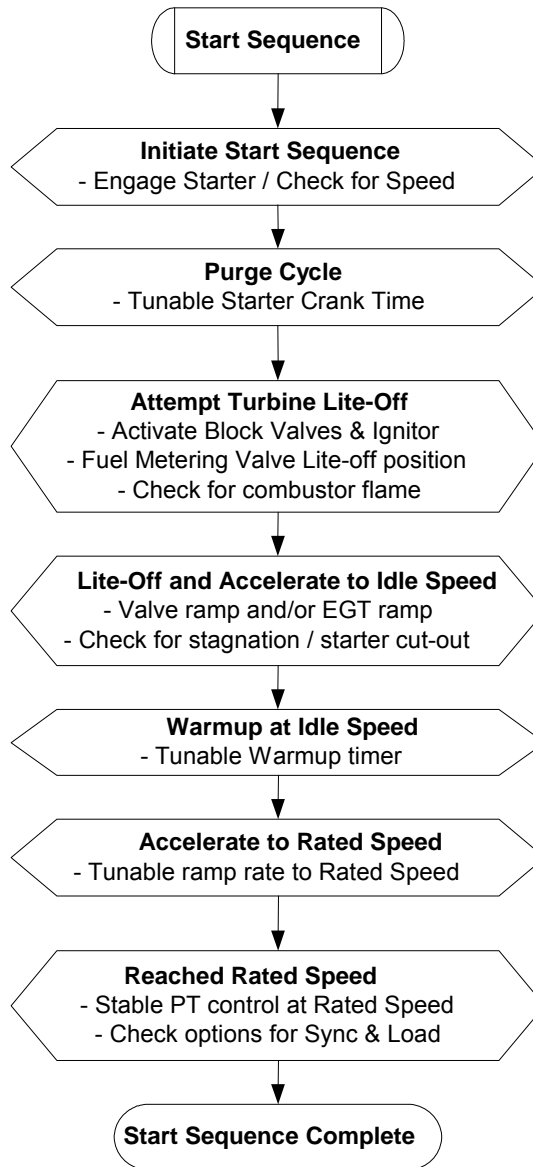

Figure 6-1. Auto Start/Stop Sequence

The following sections will explain the sequence logic above and identify items that are configurable by the user in each step.

## Initiate Start Sequence

After receiving a start command the control will check all of the start permissives, which is a logical AND of the following:

- No Shutdowns present
- Unit not in Calibrate mode
- EGT temp is less than 400 deg F
- Fuel Shutoff Valves are Closed
- Fuel Metering Valve at minimum position
- Speed reference setpoint at minimum value
- Any of the customer Start Permissive inputs

If these are all TRUE then the control will energize the Motor Starter relay output and wait to detect that the speed probes are reading a speed above the minimum starter crank speed, if no speed is detected within the required time then an alarm is issued. Once speed is detected the Sequence moves into the Purge Cycle step.

Configuration Items:

Minimum Crank Speed (rpm)	*500 (100, 2000)
Time to wait for Speed detection (sec)	*10 (1, 120)

## Purge Cycle Sequence

The control will allow the turbine to crank on the starter motor for the amount of time that the user configures for the purge time. This allows for any required purge of the internal turbine air and any downstream boiler system, if no boiler is present then this time can be minimized. Once this timer is complete the control will move to the Attempt Lite-off step.

Configuration Items:

Purge Cycle Time (sec)	*30 (2, 1200)
------------------------	---------------

## Attempt Lite-off / Activate Fuel Shutoff Valves & Ignitor

At this step the control will issue relay commands to open the fuel shutoff valves for the selected fuel type and turn on the ignitors. The control will wait for the configured time to see that a flame has been established in the combustor (via one of the selected options for flame detection). If the control does not get this indication then a shutdown command is issued and annunciated as a Failed to achieve Lite-off. Once Lite-off is achieved the sequence proceeds to the Lite-off and Accel step.

Configuration Items:

Time to wait for Lite-off on Gas Fuel (sec)	*10 (2, 30)
Time to wait for Lite-off on Liquid Fuel (sec)	*20 (2, 30)

\*Note – be sure the time is correct for the chosen fuel.



## Lite-off and Accel to Idle Speed

At this step the control begins to ramp open the fuel start ramp and will continue on this control, or one of the other start mode options, up to the minimum idle speed setpoint. During this acceleration the speed will pass through the Starter cutout speed, which is when the Motor Starter relay will drop out. The control has a configurable timer during which it must reach the minimum idle speed setpoint (Idle). If it does not reach idle speed within this time frame a shutdown command is issued and annunciated as a Speed Failed to Accel. Once Idle speed is reached then the sequence proceeds to the Warm-up step.

### Configuration Items:

Maximum Time to Accel to Idle speed (sec)	*120 (5, 600)
Motor Starter Cut-out Speed (rpm)	*1000 (100, 5000)
Idle Speed = Min Speed Reference	Set in System Config

## Idle Warm-up Cycle Sequence

At this step the control will hold the unit at idle speed for the amount of time configured by the user. At the end of this cycle the unit will issue a pulse to begin ramping the speed reference to the rated setpoint. At this point the sequence proceeds to the Accelerate to Rated Speed step.

### Configuration Items:

Time to Warm-up at Idle Speed (sec)	*30 (5, 600)
Raise Speed Ref at Fast Rate(F=Default Rate)	*True
Speed Reference Fast Rate (rpm/sec)	*100 (5, 1000)

## Accelerate to Rated Speed Sequence

At this step the control will begin to raise the speed reference at the default or fast ramp rate, as determined by the user. If control at rated speed is not achieved in the configured time allowance then a Shutdown command is issued and annunciated as Speed Failed to Accel. It is important to set this timer to a calculated amount of time in which the speed should reach rated speed (using the programmed ramp rate and rpm range between Idle and Rated). Once the unit achieves control at Sync speed the sequence proceeds to the Reached Rated Speed step.

### Configuration Items:

Maximum Time to Accel to Rated (sec)	*60 (5, 600)
--------------------------------------	--------------

## Reached Rated Speed Sequence

At this step the control looks to determine that the turbine is in speed control at rated speed. Once this is confirmed the Start Sequence is completed.

At this point the Start Sequence is completed.

## Initiate a Normal Stop Sequence

The user can elect to initiate a normal stop sequence that will bring the unit down from any operating point at Rated Speed or above. The sequence is initiated by receiving a Normal stop command pulse. The control will ramp down the Speed reference to the minimum load point and then open the generator breaker. After gaining speed control at rated speed, the control will ramp down the speed reference from the rated setpoint to the minimum setpoint (Idle Speed). Once this is achieved the control will hold the unit at this speed until the configured cool down timer has expired. At this point the control will shutoff fuel (both the metering valve and the shutoff valves). When the EGT temperature falls below 400 degrees F then the unit is considered to be shutdown and the normal stop sequence is complete. There is not provision in this sequence to initiate any motoring of the starter, turning gear, or ratchet control logic. This must be done in MP.

### Configuration Items:

Time to Cool down at Idle Speed (sec)	*30 (5, 600)
Minimum Load MW Setpoint (mw)	*5 (1, 100)

## Event Annunciation (Alarms/Shutdowns)

When an event occurs, the application sets a numbered Alarm flag (listed as AL\_ xxx), which is latched as per the list in Appendix C. The action to be taken is determined by the configuration option that the user selects for each event. These alarms all have a user tunable value for the configuring the action of each event. The programmed default actions for these events are shown in the list below. The ACKNOWLEDGE input will turn off the Horn output. The RESET will clear the event latch, if the event condition no longer exists. The options are as follows:

Configuration Number	Description
1	Disabled (No action taken) – for not used events
2	Alarm (Audible & Visual annunciation of event)
3	Soft Shutdown (same as Alarm w/ Open Gen Breaker Command)
4	Hard Shutdown (same as Soft w/ Fuel Shut-off)
5	Reserved (MultiProg defined sequence)

## Alarm Sequence

When the fuel control detects an alarm condition, it activates a summary alarm and horn output that can be tied to relay outputs. The first 300 events are triggered by actions in the GTC190 GAP application – any events greater than 300 are triggered by the Multiprog application. The control sends a numeric value along with information about the specific cause of the alarm out through the Modbus block. Using the Woodward service tools the customer can also find the numeric alarm value that corresponds to the numbered alarms found in Appendix C of this manual. An acknowledge signal will clear the horn annunciation of the event. A reset will clear the alarm, if the condition that initiated it no longer exists. If it still exists the latch will remain set.

## Soft Shutdown Sequence

When a soft shutdown occurs, either a fuel control initiated event or a discrete input contact configured for a soft shutdown, the unit will open the Generator Breaker to take all load off of the turbine. The GTC will send information as to the specific cause of the shutdown out through the Modbus block. The customer can also go into Service mode and view a numeric shutdown value that corresponds to the numbered shutdowns found in Appendix C of this manual. An acknowledge signal will clear the horn annunciation of the event. A reset will only clear the shutdown if the condition that initiated it no longer exists. The soft shutdown stack and sequence are overridden if a hard shutdown event occurs. This will make the annunciation of the trip clear to the user by the first out indication. If the GTC annunciates a first out indication for both a soft and a hard shutdown – that indicates that the first event was the soft shutdown event, immediately followed by the hard shutdown event indicated.

## Hard Shutdown Sequence

When a hard shutdown occurs, either a fuel control initiated event or the discrete contact shutdown input, all of the actuator signals go to zero, the fuel shutoff valve outputs (if used) go False, and the Generator Breaker will be commanded Open which will cause the turbine to shutdown. The fuel control will activate a summary shutdown relay output and also send information as to the specific cause of the shutdown out through the Modbus block. The customer can also go into Service mode and view a numeric shutdown value that corresponds to the numbered shutdowns found in Appendix C of this manual. An acknowledge signal will clear the horn annunciation of the event. A reset will only clear the shutdown if the condition that initiated it no longer exists AND the PT speed has dropped below the user defined speed setpoint. This is done to insure that there is no attempt to re-light the turbine while it is in a shutdown mode.

When a hard shutdown occurs it will override the soft shutdown stack – so that those events will not come in as nuisance events, since the breaker will be opened as a result of the hard trip.

## Setup of PT Speed Control

The GTC190 requires that the user setup reference parameters and dynamic gain values in order to control the PT (Power Turbine) Shaft speed of the turbine. The control will create a ramp function based on the upper and lower reference limits defined by the user. This ramp will move at one of 3 rates – Default, Fast and Instant. The user defines the first 2 of these rates in units of rpm/sec. There are 3 optional speed switches that are connected to relay outputs. These signals can be use to assist any sequencing or auxiliary logic that may be performed by another external device. The user can define the speed setpoints for each of these switches.

There are also a few other PT speed options available for the user.

- Option of implementing dual dynamics, such that one set of speed PID gain values are used in one operating mode (such as Isoch mode) and a second set of dynamics can be used while in a different operating condition (such as Droop mode)
- Ability to enable an PT Overspeed test – which will allow the user to adjust the Overspeed Setpoint in the control while operating (THIS DOES NOT BIAS THE PHYSICAL SPEED IN ANY WAY)

- Option to automatically override the failed PT speed probe signals until the control determines that it should be receiving some valid speed signal

These parameters must be defined before the control is used to run the turbine. If the PID gain values are not known, then the control dynamics may be adjusted for desired performance, once the turbine is running, by following the procedure detailed in the Troubleshooting section below.

Configuration Items:

Service/Configuration Worksheet: PT SPEED CONTROL SETUP

## Setup of the Accel Control–PID or Limiter Curve

The GTC190 requires that the user configure either a Speed derivative PID or a fuel limiter curve based on the compressor discharge pressure of the turbine. The purpose of this logic is to protect the turbine from overfueling (acceleration limiter) by limiting the maximum fuel valve position, especially during transient events.

The speed derivative PID uses a calculated derivative of the sensed speed as the process input and a setpoint as an rpm/sec limiting value. This setpoint can come from a curve output or a MP determined parameter.

The CDP/Fuel Schedule uses the CDP (as the X value) as scaled by the user. The output of the curves block (Y value) limits the LSS bus in scale of 0-100% (that is, if output is 50 for a given input, then fuel flow will not be able to increase above 50% valve demand). There are separate curves for gas and liquid fuel—if the turbine is a single fuel unit then the unused fuel curve should have all Y values set to 100%.

To calculate the correct X and Y values for this curve, one of the following methods should be used.

- Turbine OEMs typically define a curve of Compressor Discharge Pressure vs. Fuel (in BTU/hr) in the control or installation manuals for the turbine. The user should get the heating value of the fuel used at their installation site and translate this curve into a CDP vs. Fuel Flow curve. The user should then plot their fuel valve flow output (in PPH) versus demanded position (%) and create an appropriate CDP vs. Fuel Valve demand curve. Further information of the creation of this curve can be found in the Troubleshooting section.
- The user could record data from their unit while it is currently running and generate a CDP vs. Fuel Valve demand curve. This method should contain a full range of data points (sub-rated PT speed & under load conditions). The Appendices of this manual contain a sheet to assist in this effort.

Configuration Items:

Service/Configuration Worksheet: CDP TO FUEL LIMIT CURVE  
ACCEL CONTROL PID

## Setup of the Decel Curve Setup

The GTC190 allows the user to configure a curve to protect the turbine from under fueling (flame out) conditions. The user will configure a minimum fuel limiter curve based on the compressor discharge pressure of the turbine. The Decel curve uses CDP (as the X value) as scaled by the user. The output of the curves block (Y value) limits the LSS bus in scale of 0-100% (that is, if the output is 10 for a given input, then fuel flow will not be able to decrease below 10% valve demand). There are separate curves for gas and liquid fuel—if the turbine is a single fuel unit then the unused fuel curve should have all Y values set to 100%. The curve is defined with a maximum of 5 breakpoints and should be tuned in sequence from X-Y values 1 through 5, with any unused points at the end tuned high (out of the way). If a constant minimum fuel percent limit is desired the Y values of the curve can be made equal, defining a flat line output.

Configuration Items:

Service/Configuration Worksheet:      DECEL CURVE (CDP) SETUP

## Setup of EGT Temperature Control

The GTC190 allows the user to setup an EGT control loop to limit the maximum EGT temperature of the exhaust gas output of the turbine. The user can adjust the EGT setpoint and dynamic gain values of the PID. This function is typically used as a turbine protection / topping limiter. This control loop also has an option to allow the user to include EGT limiting during the initial starting of the turbine. The user can enable this function and setup low temp and high temp setpoints that will define a ramp which will be used during initial start to limit the fuel valve position through this range. The user must also define a rate at which the control will ramp up the temp setpoint (from low to high), so that the turbine can continue to accelerate up to PT control. This function helps to eliminate potential overtemp shutdowns on initial startup by providing closed loop control at sub-PT Idle conditions. The EGT control automatically resumes to being a topping control once the turbine has reached PT speed control.

Configuration Items:

Service/Configuration Worksheet:      EGT CONTROL SETUP

## Setup of EGT Temp Derivative Control

The GTC190 allows the user to setup a control loop to limit the maximum rate of change of the EGT temperature. The user can adjust the EGT\_DERIV setpoint and dynamic gain values of the PID. The setpoint can be a fixed value (in Degrees F per second) or can come from a curve that uses either CDP or speed as a forcing function. Use caution if both this and the EGT start limiter functions are both being actively used. The limiter requesting the least amount of fuel will control the fuel metering valve. If it is desired to use this PID on startup then it is best to disable the Start Temp Limiter.

Configuration Items:

Service/Configuration Worksheet:      EGT\_DERIV CONTROL SETUP

## Setup of Generator Settings

The GTC190 allows the user to setup a MW control loop to limit the maximum MW output of the turbine. The user can adjust the MW setpoint and dynamic gain values of the PID. This function is typically used as a turbine protection / topping limiter and can also be used to limit the overall MW or horsepower output of the turbine.

Configuration Items:

Service/Configuration Worksheet: GENERATOR SETTINGS

## Setup of Load Sharing

The GTC190 has the capability to communicate with other GTC products, as well as other Woodward power management products, to allow Load Sharing of multiple units on a local power bus. When the units (either gas turbines or diesel generator sets) are isolated from the Utility bus, the LON communication link will allow these devices to balance the output of all available units to supply the total load on the local bus. This mode is described as Isochronous Load Sharing.

NOTE: If it is desirable to include a unit (or units) that load share via an analog signal (such as a Woodward Real Power Sensor) then another device should be added. The Woodward Load Sharing Interface Module (LSIM – p/n 8239-082) will provide a gateway to convert the analog load share signal into a LON signal that can be tied into the above mentioned digital load sharing products.

Configuration Items:

Configuration Worksheet: SYSTEM

Use Load Sharing Option	*True
Transfer Rate In/Out of LS (sec)	*10 (0.1, 60)
Use LON Communication Link	*True

## Synchronizer

The GTC190 control uses digital signal processing techniques to derive both true RMS voltages and relative phase of the fundamental frequencies of the bus and generator voltage wave forms. Digital signal processing techniques offer significantly improved measurement accuracy in the presence of waveform distortions, particularly since the phase measurement does not depend on zero crossings of the waveforms.

Either phase matching or slip frequency synchronizing may be selected. **Phase matching** method controls the engine speed to give zero speed error and minimal phase error between the generator and bus; this provides rapid synchronizing for critical standby power applications. **Slip frequency** synchronizing guarantees a fixed speed difference between generator and bus. This insures the generator to be faster than the bus and initial power flow is out of the machine for larger generators. For both synchronizing methods, the GTC190 control uses actual slip frequency and breaker delay values to anticipate a minimum phase difference between bus and generator at actual breaker closure.

The synchronizer can sense a dead local bus and close the generator circuit breaker automatically when safe to do so. The network communication between GTC190 control assures that multiple generators cannot close simultaneously onto a dead bus.

There are four synchronizer modes of operation: Run, Check, Permissive, Off. The mode can be selected through Watch Window or Modbus. The last mode selected by any of these interface methods will be the mode of operation.

**Off mode (1)**, the GTC performs no synchronization functions, The running sequence would stop with the engine at rated speed, and an external function would be required to close the breaker and continue the sequence.

**Check (2)** mode is used to confirm that the synchronizer works properly by allowing synchronizing to be performed but not closing the breaker. The Synchronizer status screen can be used to observe the Slip, Phase, and voltage indication, (Displays ++ when matched). In the Check mode these indication must match external metering and wiring before allowing the breaker to close.

**Permissive (3)** mode is used to replace a sync check relay function, the bias outputs are passive, but the breaker command will be given when speed, phase, and voltage parameters are within the window.

**Run/Auto (4)** mode is the normal mode with active synchronizing and breaker control.

Additional synchronizer features include: voltage matching, time delayed automatic multi-shot reclosing, and a synchronizer timeout alarm. Raise and lower inputs can be used to manually adjust speed for manual synchronizing. Voltage raise and lower inputs can be used to manually adjust voltage for manual voltage matching. Each of these features may be enabled or disabled during setup.

Configuration Items:

Service/Configuration Worksheet: SYNCHRONIZER

## Load Control

The GTC190 has 3 different modes for controlling the turbine load. Isochronous, Droop and Isochronous Load Sharing

### Droop Mode

When the generator circuit breaker is closed and the utility breaker is closed then the unit is in droop operation. The turbine load will be directly proportional to the speed reference signal, which can be manipulated by Raise/Lower commands, a Remote speed reference signal (analog input) or a Modbus or ServLink DDE communication interface. The load reference can also be driven indirectly through the Process control mode. When the breaker tie to the utility is initially closed the unit will step up to a minimum load setpoint to insure that the breaker does not open due to reverse power. From this minimum load point the user can load the unit as desired or have the control automatically ramp the unit to a base load setpoint.

The typical application of simple load droop operation is with a unit that normally operates in parallel with a Mains (utility) bus.

### Isochronous Mode

When the generator circuit breaker is closed, the utility breaker is open and the Load Sharing mode is not enabled, then the unit is in Isochronous mode and will handle all plant loads up to the upper load output limit of the turbine.

The typical application of this mode is when a single unit is a stand-alone power generation site that does not tie to the utility or a unit that droops against the utility but needs to maintain all of the plant load when the utility breaker is opened.

### **Isochronous Load Sharing Mode**

When the generator circuit breaker is closed, the utility breaker is open and the Load Sharing mode is Enabled, the unit will Load Share with other units connected to the bus. The load sharing signal will control the load of each engine by slight changes to the speed control's speed reference.

The typical application of this mode is when a unit is part of a group of stand-alone power generation units at a site that does not tie (or is not currently tied to) the utility.

Configuration Items:

Service/Configuration Worksheet:	SYSTEM SETUP Initial Mode @ Breaker Closure
Service/Configuration Worksheet:	REAL LOAD CONTROL

## **Process Control**

Process Control is a cascade control mode that manipulates the PT reference to maintain the process operation setpoint. Flexible controller adjustments, an adjustable deadband, and direct or indirect control action, allow the process control to be used in a wide variety of applications. The typical implementations of this feature include, import/export control, pressure maintenance, or other plant dependent load setpoint parameters. In the GTC190 it is only available when in Droop mode running in parallel with a utility grid.

A 4–20 mA (or 1–5 Vdc) process transmitter provides the process signal to the GTC190 control. The control includes an internal digital process reference value which may be controlled by raise and lower switch contact, or by a Modbus or ServLink communication interface. The output of the process control provides the cascade load reference to the Load control.

Adjustable ramps allow smooth entry to or exit from the process control mode. When the process control mode is selected, an adjustable ramp moves the load reference in a direction to reduce the process control error. When the error is minimized, or the reference first reaches either the specified high or low load pick-up limits, the process controller is activated.

Additional functions include selectable and adjustable process high and low limit switches and alarm activation.

Configuration Items:

Service/Configuration Worksheet:	PROCESS CONTROL
----------------------------------	-----------------



## VAR/PF Control

The VAR/PF functions control the reactive power component of the generator in parallel systems. The reactive load mode can be configured for VAR or Power Factor control. The controller compares the reactive load on the generator with an adjustable internal reference and makes corrections to the setpoint of the Automatic Voltage Regulator (AVR) until the desired reactive power is obtained. The reactive power level can be maintained while also controlling real load through the generator breaker. The analog voltage bias output can be directly connected to compatible voltage regulators. The control also has raise and lower contact outputs to activate a voltage regulator MOP when an analog input is not provided on the AVR. The GTC190 control has a selectable voltage range alarm that is activated if the analog output to the voltage regulator reaches high or low saturation. The GTC190 control also has selectable and adjustable high and low voltage limit switches and alarm outputs.

The GTC190 control provides switch inputs to allow raising or lowering the generator voltage reference. The control also provides a 4–20 mA (or 1–5 Vdc) analog input for kVAR/PF setpoint control, if desired. The kVAR/PF reference can also be set through a Modbus or ServLink DDE communication interface.

While the GTC190 is controlling unit load to accomplish real load (kW) sharing, the voltage of the generators in parallel will be controlled to accomplish equal Power Factor levels of each generator.

Configuration Items:

Service/Configuration Worksheet: REACTIVE LOAD CONTROL

## Power and Energy Metering

The digital signal processing techniques are used to provide significantly improved accuracy and speed of response over conventional analog measurement techniques. Accuracy is improved using rapid sampling of the voltage and current signal waveforms and developing a true RMS measurement. Measuring true RMS power allows optimal accuracy, even in the presence of power line distortions.

The PowerSense board receives the PT and CT inputs for both the generator and bus for calculation of parameters for the GTC to use in system control. The algorithms used are based on IEEE 1459-2000. For the generator and bus the following parameters are provided: Hz, Vac, Amps, W, VA, VAR, PF, Phase, Voltage harmonics, Current harmonics, Negative Phase Sequence Voltage, Negative Phase Sequence Current.

Available for selection at the 4–20 mA analog outputs: Synchroscope, Generator metering, Mains metering

## Protective Relaying

Alarms can be configured for generator and bus protective relay (i.e. Reverse power, Under Voltage) functions. Time delay, and separate warning and trip thresholds can be set. A complete list of protective relay functions available is given in the next chapter. Current based protections are implemented using the ANSI/IEEE C37.112 Very Inverse curve.

Configuration Items:

Service/Configuration Worksheet: ALM/SD EVENTS

## Tunable Upload/Download Function

The TUNABLE UPLOAD & DOWNLOAD functionality is used for downloading or uploading tunables into or out of the control. The tunables may be downloaded from the control to a PC anytime, however the turbine must be shutdown while using the TUNABLE UPLOAD FUNCTION mode.

### **NOTICE**

**Entering into I/O Lock mode while the turbine is running will cause an automatic shutdown of the turbine with resulting process stoppage. Do not enter the I/O Lock to upload tunables into the control while the turbine is running.**

From WW, go to the Explorer Window and 'right-mouse' click on the control (top level). A pull-down menu will appear and the App Settings selection will allow you to Save to File or Load from File.

- SAVE = Download the tunables in the control to a file on the user PC
- LOAD = Upload tunable settings from a user PC into the control

Loading tunables into the control will cause the unit to Lock the I/O and shutdown the turbine.

### **IMPORTANT**

**It is highly recommended that the user keep a current tunable list file available at site. This will make the configuration and setup of a spare unit very simple and assist in troubleshooting system problems.**

# Chapter 7.

## Generator Protection Functions

### Protective Relay Descriptions

The table below gives some summary information about each type of protective relay function provided. Details for each follow the table. Note that the Alarm and Pre-Alarm Time Delays are used for both high and low conditions.

Name	Functionality	Type
Generator Under/Over Voltage (27,59)	Alarm and Pre-Alarm capability	Definite Time
Generator Over/Under Frequency (81O, 81U)	Alarm and Pre-Alarm capability	Definite Time
Generator Over/Under Power	Alarm and Pre-Alarm capability	Definite Time
Generator Directional Power Relay (32)	Alarm and Pre-Alarm capability	Inverse Time
Generator Negative Phase Sequence Over Voltage (47)	Alarm and Pre-Alarm capability	Definite Time
Generator Negative Phase Sequence Over Current (46)	Alarm and Pre-Alarm capability	Definite Time
Generator Phase Over Current (51)	Alarm and Pre-Alarm capability	Inverse Time
Generator Directional VAR Relay	Alarm and Pre-Alarm capability	Definite Time
Generator Phase Current Differential Imbalance relay (87)	Alarm and Pre-Alarm capability	Inverse Time
Sync Check (25)	True / False (no alarm)	Definite Time
Voltage (VAR/PF) Adjust Limits Reached	High and Low Alarms	Definite Time
Speed / Frequency Mismatch	Alarm only	Definite Time

### Over and Under Voltage

The Over and Under Voltage protective relay is definite time. It operates by comparing the actual voltage to the level set points for this relay. The highest voltage of the 3 phase inputs is always used for the Over Voltage protective relay. Likewise, the lowest voltage of the 3 phase inputs is always used for the Under Voltage protective relay. Once an alarm is issued, it is latched until the GTC is reset. The generator Under Voltage relay is automatically disabled anytime the generator breaker is open. The Bus Under Voltage relay, Generator and Bus Over Voltage relays are not inhibited by breaker position.

The action to be taken for an Over Voltage Pre-Alarm, Over Voltage Alarm, Under Voltage Pre-Alarm, and Under Voltage Alarm are all independently configurable. There are separate Delay times for Pre-Alarm and Alarm. The delay times for Over Voltage and Under Voltage are identical but Generator and Bus are independently configured.

The Alarm and Pre-Alarm trigger levels for an Over Voltage Pre-Alarm, Over Voltage Alarm, Under Voltage Pre-Alarm, and Under Voltage Alarm are all independently configurable. The worst case phase voltage must exceed the configured level continuously for the delay time before the Alarm or Pre-Alarm action is taken.

The diagram below shows how the Pre-Alarm and final Alarm events are envisioned to operate. Note that the delay times are identical between Over and Under Voltage event examples but the trigger levels are all separately configurable.

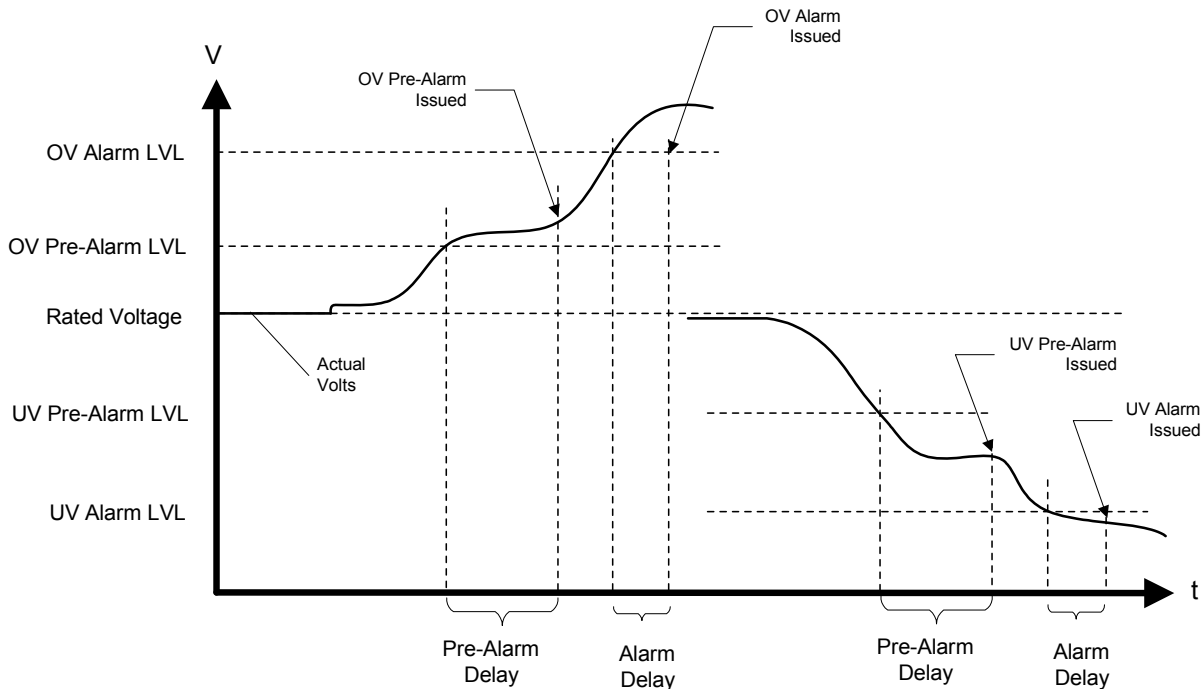

Figure 7-1. Over Voltage/Under Voltage Alarm

## Over and Under Frequency

The Over and Under Frequency protective relay is definite time. It operates by comparing the actual frequency to the level set points for this relay. Once an alarm is issued, it is latched until the GTC is reset. The generator Under Frequency relay is automatically disabled anytime the generator breaker is open. The Bus Under Frequency relay, Generator and Bus Over Frequency relays are not inhibited by breaker position.

The action to be taken for an Over Frequency Pre-Alarm, Over Frequency Alarm, Under Frequency Pre-Alarm, and Under Frequency Alarm are all independently configurable. There are separate Delay times for Pre-Alarm and final Alarm. The delay times for Over Frequency and Under Frequency are identical but Generator and Bus are independently configured.

The Alarm and Pre-Alarm trigger levels for an Over Frequency Pre-Alarm, Over Frequency Alarm, Under Frequency Pre-Alarm, and Under Frequency Alarm are all independently configurable. The frequency must exceed the level continuously for the delay time before the Alarm or Pre-Alarm action is taken.

The diagram in Over and Under Voltage above shows how the Pre-Alarm and final Alarm events are envisioned to operate. The Over and Under Frequency protective relay function operates in the same manner as the Over and Under Voltage protective relay function.

## Directional Power

The Over and Reverse Power protective relays are inverse time. They operate by comparing the actual real power to the level set point for this relay. Only real power is of interest for this protection. Over power for the generator is power flowing out of the generator (produced by the generator). Over power for the Bus is defined as power flowing into the Bus (same relationship as generator). Over power for the Bus is denoted as Export Power and Reverse Power for the Bus is denoted as Import Power.

A configurable time delay setting is provided to shift the inverse time curve along the time axis. This movement allows adjustment of the minimum trip time at the configured level. The same shifted curve is used for Pre-Alarms and Alarms so a time shift done for one will affect the other as well. The same shift is also applied to both the Over Power and the Reverse Power protective relays.

The power level must exceed the level continuously for the calculated delay time before the Alarm or Pre-Alarm action is taken. The delay time is recalculated each time the power level changes. Once an alarm is issued, it is latched until the GTC is reset. The Directional Power relays are continuously enabled.

The below graph shows how the Pre-Alarm (warning) and final Alarm settings relate to actual and rated power levels. Notice the delay time for the over power pre alarm is longer than the delay time for the over power alarm. This time difference results from the difference in the actual power compared to the pre-alarm and alarm set points. A long time delay is seen when the actual power is only slightly higher than the pre-alarm level. When the actual power goes above the alarm level it goes noticeably higher so the time delay is shorter. In order to determine the calculated delay and to see how the curve shift is used, refer to the second graph below.

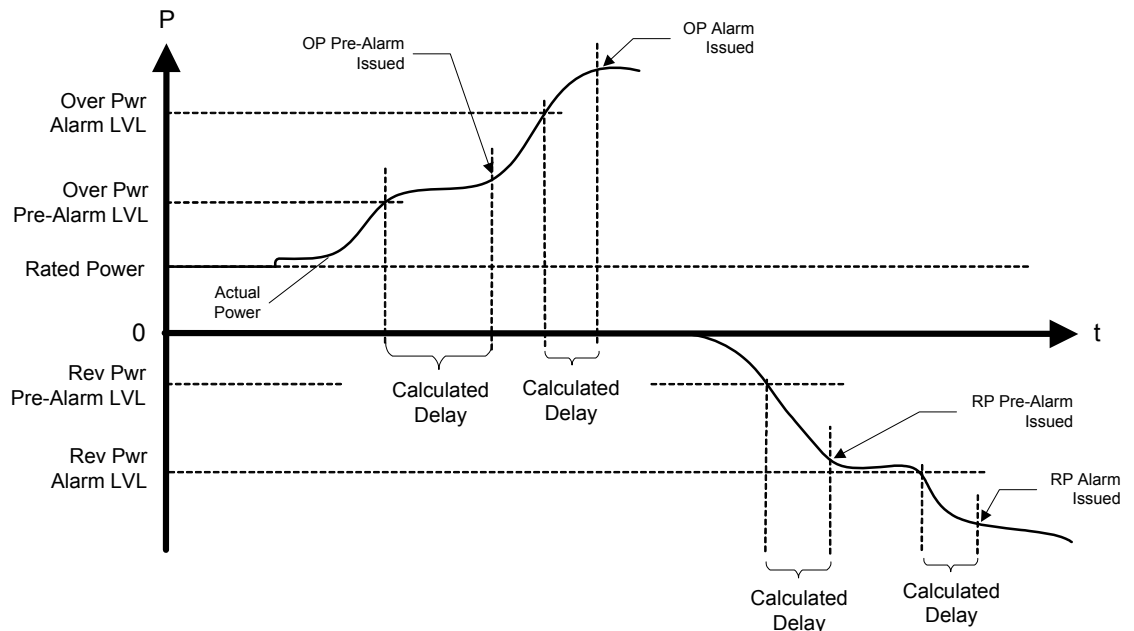

Figure 7-2. Over Power/Reverse Power

The graph below shows how the inverse time curve is applied to the directional power protective relay. Note the same curve shift applies to both Over and Reverse Power. Likewise, for the Bus, the same curve shift would apply to both Import and Export Power but is different than the curve shift used for the generator directional power protective relay.

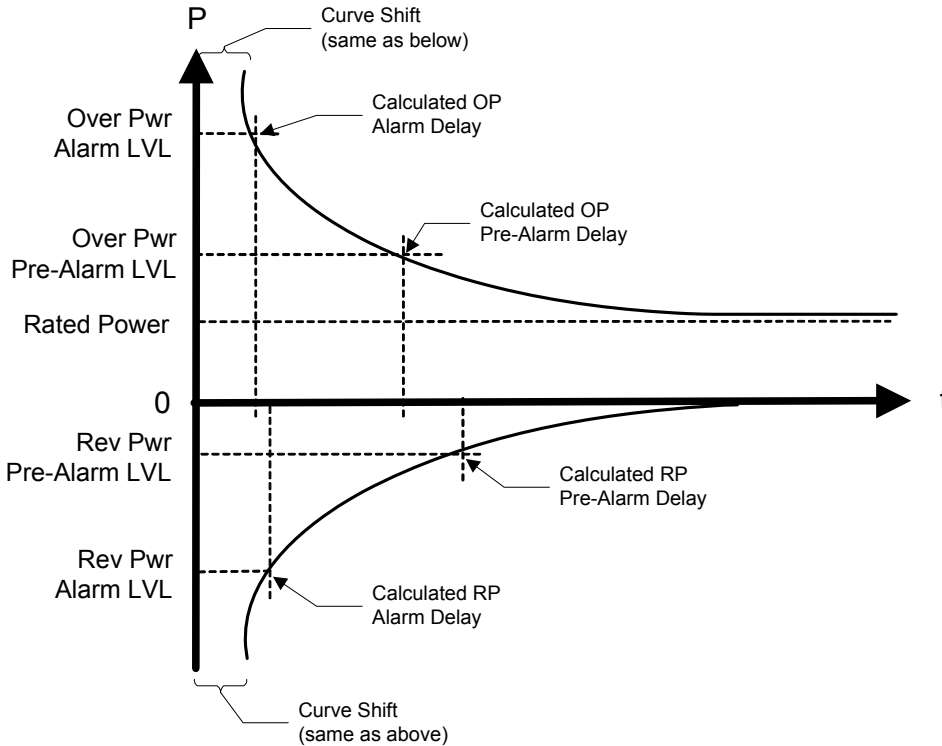

Figure 7-3. Over Power/Reverse Power Time Delay

## Negative Phase Sequence Over Voltage

Negative Phase Sequence Voltage (NPS) is a measure of the imbalance in a three phase system. Any imbalance due to unequal voltage amplitude of the three phases or a phase angle error between phases creates NPS voltage. A completely balanced system with positive phase sequence generates 0% NPS voltage. Complete loss of one phase results in 50% NPS voltage, a 100% NPS voltage would result from a balanced system with reversed phase sequence. The NPS protection function must know the correct (expected) phase rotation in order to function properly.

Typical causes of voltage unbalance are large unbalanced loads (single phase loads in the system) and unbalances in the supply due to transformer designs or other customer loads in the power system. The most common effect of voltage unbalance (detected by NPS voltage) is rotor overheating on 3-phase motors.

For installations where significant regenerated EMF may occur (lifts, cranes, or similar), a sensitivity of 5%-7% is recommended above what is necessary for the system unbalance. To avoid tripping on system transient disturbances, this relay should be configured with a timeout from 2 to 4 seconds.

This Negative Phase Sequence Over Voltage protective relay is a definite time relay. As the name implies, it tracks levels ABOVE a configured setting. It operates by comparing the actual Negative Phase Sequence Voltage with the level set point for this relay. Once an alarm is issued, it is latched until the GTC is reset. The Negative Phase Sequence Over Voltage relays are continuously enabled.

The actions to be taken for a Negative Phase Sequence Over Voltage Pre-Alarm or a Negative Phase Sequence Over Voltage Alarm are both independently configurable. The Negative Phase Sequence Over Voltage trigger levels are also independently configurable for the Pre-Alarm and Alarm. There are separate Delay times for Pre-Alarm and Alarm. The Negative Phase Sequence Voltage must exceed the trigger level continuously for the delay time before the Alarm or Pre-Alarm action is taken.

The diagram in Over and Under Voltage above shows how the Pre-Alarm and final Alarm events are envisioned to operate. Only the Over Voltage portion of the diagram is used. The Negative Phase Sequence Over Voltage protective relay function operates in the same manner as the Over Voltage protective relay function.

## Negative Phase Sequence Over Current

This Negative Phase Sequence Over Current protective relay is a definite time relay. The negative phase sequence over current is derived the same as the voltage above. Once an alarm is issued, it is latched until the GTC is reset. The Negative Phase Sequence Over Current relays are continuously enabled.

The actions to be taken for a Negative Phase Sequence Over Current Pre-Alarm or a Negative Phase Sequence Over Current Alarm are both independently configurable. The Negative Phase Sequence Over Current trigger levels are also independently configurable for the Pre-Alarm and Alarm. There are separate Delay times for Pre-Alarm and Alarm. The Negative Phase Sequence Current must exceed the trigger level continuously for the delay time before the Alarm or Pre-Alarm action is taken.

The diagram in Over and Under Voltage above shows how the Pre-Alarm and Alarm events are envisioned to operate. Only the Over Voltage portion of the diagram is used. The Negative Phase Sequence Over Current protective relay function operates in the same manner as the Over Voltage protective relay function.

## Phase Over Current

The Phase Over Current protective relay is an inverse time relay. It operates by comparing the actual phase current to the level set point for this relay. The highest current of the 3 phase inputs is always used for the Phase Over Current protective relay. Total current is not evaluated. This protective relay is NOT meant to replace a breaker.

A configurable time delay setting is provided to shift the inverse time curve along the time axis. This movement allows adjustment of the minimum trip time at the configured level. The same shifted curve is used for Pre-Alarms and Alarms so a time shift done for one will affect the other as well.

The worst case current level must exceed the configured level continuously for the calculated delay time before the Alarm or Pre-Alarm action is taken. The delay time is always being recalculated for the present current level input. Once an alarm is issued, it is latched until the GTC is reset. The Phase Over Current protective relay is continuously enabled.

The diagram in Directional Power above shows how the Pre-Alarm and final Alarm events are envisioned to operate as well as the interaction with the inverse time curve. Only the Over Power portion of the diagram is used. The Phase Over Current protective relay function operates in the same manner as the Over Power protective relay function.

## Directional VAR

The Over and Reverse VAR (Import and Export VAR) protective relay is definite time. It operates by comparing the actual reactive power to the level set points for this relay. Only reactive power is of interest for this protection. Over VAR for the generator is reactive power flowing out of the generator (produced by the generator) and is representative of lagging power factor. Over VAR for the Bus is defined as reactive power flowing into the Bus. We will refer to this as Export VAR for the Bus. Reverse VAR for the Bus will be referred to as Import VAR. Once an alarm is issued, it is latched until the GTC is reset.

The action to be taken for an Over (Export) VAR Pre-Alarm, Over (Export) VAR Alarm, Reverse (Import) VAR Pre-Alarm, and Reverse (Import) VAR Alarm are all independently configurable. There are separate Delay times for Pre-Alarm and Alarm. The delay times for Forward and Reverse VAR are identical but Generator and Bus are independently configured.

The Alarm and Pre-Alarm trigger levels for an Over (Export) VAR Pre-Alarm, Over (Export) VAR Alarm, Reverse (Import) VAR Pre-Alarm, and Reverse (Import) VAR Alarm are all independently configurable. The reactive power level must exceed the trigger level continuously for the delay time before the Alarm or Pre-Alarm action is taken.

The diagram in Over and Under Voltage above shows how the Pre-Alarm and Alarm events are envisioned to operate. The Directional VAR protective relay function operates in the same manner as the Over and Under Voltage protective relay function.

## Phase Current Imbalance

The Phase-balance Current protective relay is an inverse time relay. It operates by comparing the actual current between each phase to the level set point for this relay. The highest differential current of the 3 comparisons is always used for the Phase Current Imbalance protective relay.

A configurable time delay setting is provided to shift the inverse time curve along the time axis. This movement allows adjustment of the minimum trip time at the configured level. The same shifted curve is used for Pre-Alarms and Alarms so a time shift done for one will affect the other as well.

The worst case current differential must exceed the trigger level continuously for the calculated delay time before the Alarm or Pre-Alarm action is taken. The delay time is always being recalculated for the present current imbalance level input. Once an alarm is issued, it is latched until the GTC is reset. The Phase Current Differential protective relay is continuously enabled.



The below graph shows how the Pre-Alarm and Alarm settings relate to actual current imbalance levels. The current imbalance levels are internally normalized against the rated current. This provides the inverse time function with a valid comparison because the IEEE definition is only valid above 1 per unit. Nevertheless, the configuration values for the Alarm and Pre-Alarm Level are to be entered as the actual allowed difference. The GTC will automatically add Rated Current to the configured value.

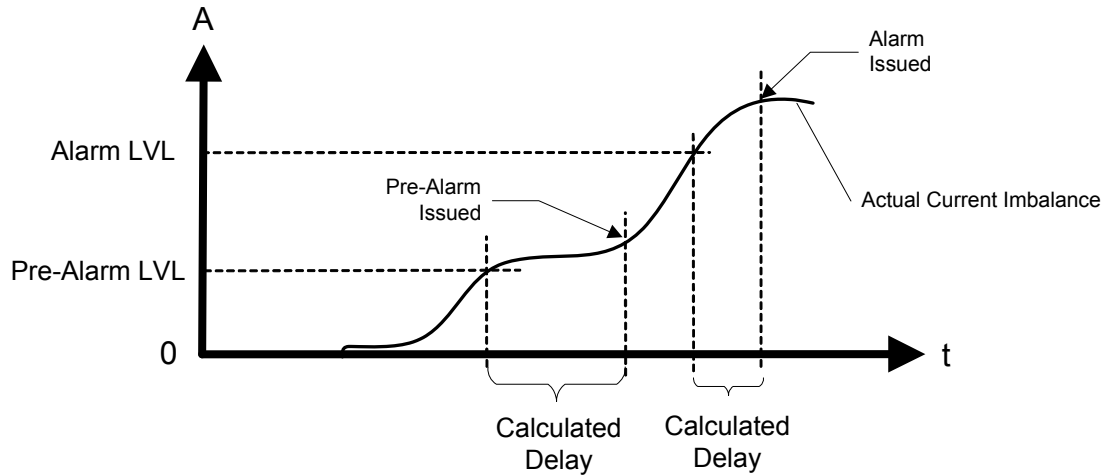

Figure 7-4. Phase Current Imbalance

In order to determine the calculated delay and to see how the curve shift is used, refer to the graph below. The Phase Current Imbalance protective relay function operates in nearly the same manner as the Over Power protective relay function except that rated current is automatically added into the percentage calculation for the IEEE inverse time curve input. The information is provided in case an exact trip time must be calculated.

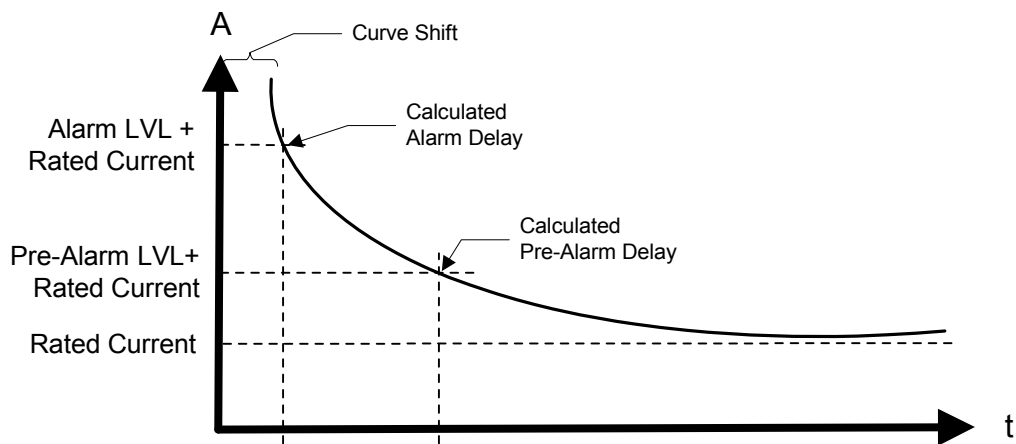

Figure 7-5. Phase-Balance Current, Inverse Time Delay

## Sync Check

The GTC synchronizer provides the Sync Check protective relay function. It is listed here due to its nature as a protective relay. It is enabled during synchronizing only. The synchronizer always performs a Sync Check function regardless of the configured mode since it will never assert the breaker close output unless the two A-phase inputs are in sync with each other. The synchronizer may also be placed in the Permissive Mode which mimics a typical ANSI 25 device by closing the output when the two sources are in sync.

## Voltage (VAR/PF) Bias Limit Reached

The Limits Reached alarm function applies to the two closed loop analog outputs – one for voltage adjust and the other for speed adjust. Each output has separate alarm due to exceeding the limits in the high direction or low direction. There is a fixed timeout of 10 seconds to ensure that a short bump into the limit does not cause an alarm. The alarm action is configurable.

This protection determines if the analog output or digital outputs (depending on configuration) have reached their limits. Since a digital output has no definite limit, the protection also reacts to the situation where the control is requesting more adjustment but the system is not responding. This condition would be indicative of reaching a limit.

## Speed / Frequency Mismatch

The Speed/Frequency Mismatch protection watches the magnetic pickup speed input and the measured frequency on the generator input. It compares the scaled value of the MPU (the rpm value) to the frequency using a simple formula. The formula also depends on the configured number of generator poles.

$$Frequency = \frac{\#GenPoles \bullet RPM}{120}$$

The purpose of this protection is partly to identify an incorrect configuration for the number of teeth but primarily to diagnose a failed MPU signal or a generator failure. If the one of the signals fail, a mismatch will occur between the measured MPU speed and the measured generator frequency. Since overspeed is determined from the MPU input, this protection is an important adder to the overspeed protection.

A fixed delay of 5 seconds is incorporated. A one hertz margin is allowed. How the alarm reacts is configurable.

## Inverse Time Curve

All protective relays that utilize inverse time trips will use the same curve shape as defined below. Each relay will be allowed to independently adjust the curve along the time axis. This adjustment does not alter the curve shape. The reason for the adjustment is to allow fine tuning of the alarm levels and timing.

The GTC takes the ratio of the input being used (phase current, power, etc.) to the rated value of that unit. The inverse time curve always uses a ratio of rated for its data element.

The inverse time curve plotted below is defined in IEEE C37.112 as the Very Inverse formula

$$Time = \left( \frac{A}{x^P - 1} + B \right) * D$$

where:

<b>Time</b>	The amount of time to wait before an alarm is issued for the given value of x. As x increases, the time will decrease.
<b>X</b>	A ratio of the measured parameter in protection to rated value.
<b>A</b>	IEEE defined constant that affects the curve shape. It is fixed at <b>19.61</b> .
<b>B</b>	IEEE defined constant that affects the curve position. It is fixed at <b>0.491</b> .
<b>P</b>	IEEE defined constant that defines the curve type. It is fixed at <b>2</b> .
<b>D</b>	Adjustable time delay. This allows the curve to be shifted along the time axis by a variable amount., <b>0.01 to 10.0, default =1.0</b>

For high alarms: If the input is less than the Alarm level and Pre-Alarm level, no action will be taken. When the input is above the Pre-Alarm level, the configured action will be taken for the pre-alarm after the timeout defined by the formula. When the input is above the Alarm level, the appropriate (and typically more severe) action will be taken after the (shorter) timeout defined by the formula.

For low alarms: If the input is greater than the Alarm level and Pre-Alarm level, no action will be taken. When the input is less than the Pre-Alarm level, the configured action will be taken for the pre-alarm after the timeout defined by the formula. When the input is less than the Alarm level, the appropriate (and typically more severe) action will be taken after the (shorter) timeout defined by the formula.

The IEEE curve implemented is the Very Inverse curve defined in IEEE C37.112 and also matches the IEC curve defined in IEC 255-03 except for the additional time shift (B) that is not defined in IEC. The formula will not function at rated or below rated for the parameter in protection. Therefore, if a trip value is set at or below rated, the timeout for these conditions will be fixed at 10 seconds. This causes a discontinuity in the curve at 100% rated. The values for A and B in the IEEE formula change at the discontinuity point. The constant A becomes 0 and the constant B becomes 10. Due to the location of the B constant and the D variable, the 10 second timeout will also adjust with the curve shift.

The figure below is a set of curves showing the IEEE Very Inverse formula plotted three times. The center plot is the default curve with no level shift, Shift value = 1.0. The upper plot is the same curve with a level shift of five. The lower plot is the same curve with a level shift of 0.1. Note the curve shape does not change. Also note the fixed timing at or below rated as shown by the straight horizontal line; and note how the fixed timing is varied with the curve shift. The GTC curve does extend to the right beyond the time shown.

Also shown below is a figure with the Inverse Time Curve converted to linear axis scale. The values used in the GTC extend above 25 second delay between 1.0 and 1.35, and also extend to the right beyond the ratio of 5.0.

**Example:** If the alarm set point is 150% of the rated (1.5 ratio) and the input is at this setpoint value and the shift = 1.0, the delay will be 16 seconds. When shift = 5, delay will be 80 seconds. When shift = 0.1, delay will be 1.6 seconds. As the input value exceeds the setpoint, the delay will become shorter.

**Example:** For an Over Current Trip Relay function: If Rated Phase Current is 500 Amps, and a trip delay of 5.0 second is desired at 700 Amp.  
Ratio = 1.4, from formula (or reading from curve below) the Normalized Delay = 20.9 sec.

$$5.0 / 21.0 = 0.24$$

The curve shift value of 0.24 is required to meet the desired level and delay requirement.

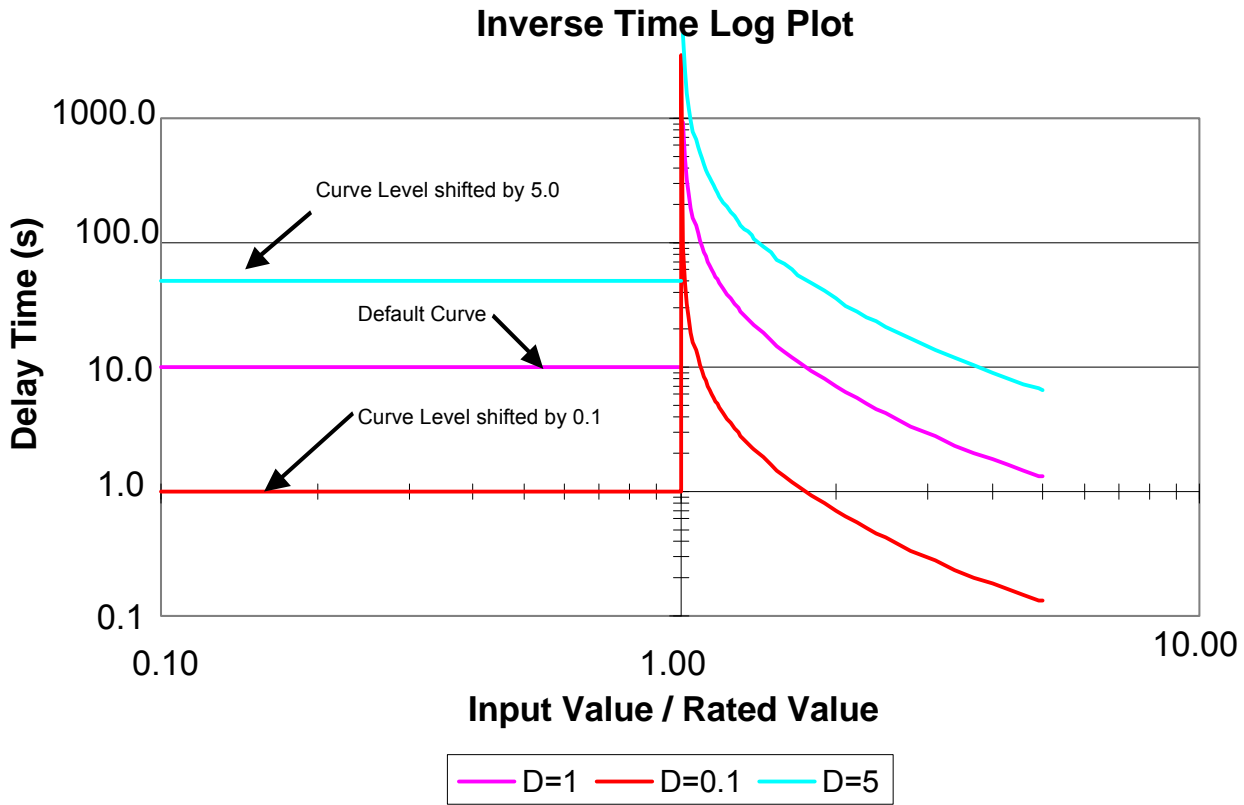

Figure 7-6. Inverse Curve Time Delay, Level Shift

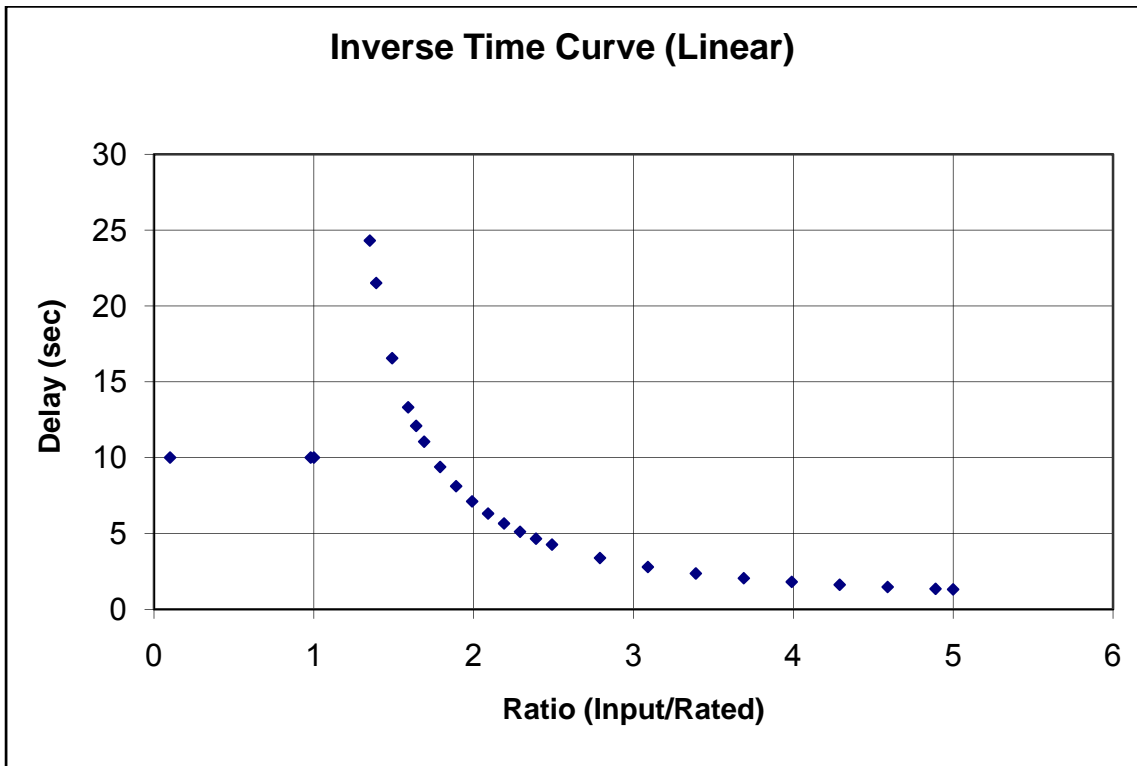

Figure 7-7. Inverse Curve Time Delay, Linear Graph

# Chapter 8.

## Troubleshooting

### Dynamic Response Problems

#### PID Controller Tuning

The majority of problems associated with the control of the turbine can be attributed to poor tuning of the PID control loops. These problems include overspeeding, overtemping, and flaming out as well as many others. For example, if the turbine control is hunting, the loop that is currently controlling the fuel valve is most likely incorrectly tuned and could cause sufficient overshoot to overspeed or overtemp the turbine. Some general tuning guidelines are outlined below.



**Tuning of PID loops should only be performed by qualified personnel that have a good understanding how the control should be performing. Improper tuning can result in overspeed or overtemp conditions, which could cause damage to the turbine or possible injury or death to personnel.**

The quality of regulation obtained from an automatic control system depends upon the adjustments that are made to the various controller modes. Best results are obtained when the adjustment (tuning) is done systematically. Prior training and experience in controller tuning are desirable for effective application of this procedure.

This procedure will lead to controller settings, which, after a load change, will provide:

- Process control without sustained cycling
- Process recovery in a minimum time

Controller settings derived for given operating conditions are valid over a narrow range of load change. The settings made for one operating set of conditions may result in excessive cycling or highly damped response at some other operating condition. This procedure should be applied under the most difficult operating conditions to assure conservative settings over the normal operating range.

There are several methods of controller tuning in use. The following procedure presents one, which will be easy to use, and at the same time minimize process upset. This method is one of systematic trial and error.

The method given is based upon the 1/4-ratio decay cycle. The peak of each cycle is 1/4 of the preceding one. The objective is to produce a trace as shown in Figure 8-1.

It is good practice to keep the average of the set point changes near the normal set point of the process to avoid excessive departure from normal operating level.

After each set point change, allow sufficient time to observe the effect of the last adjustment. It is wise to wait until approximately 90% of the change has been completed.

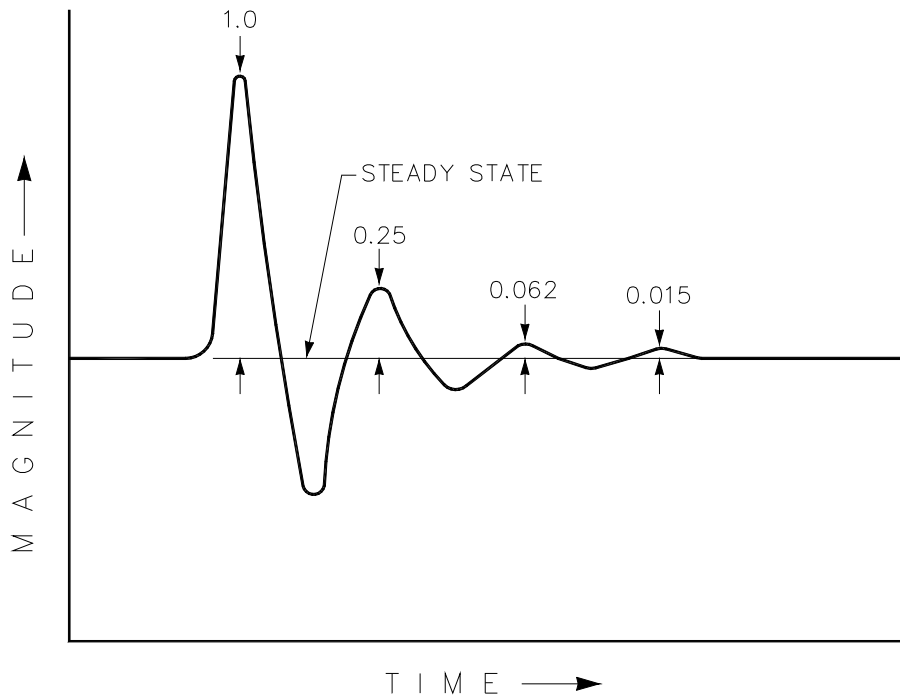

830-369  
92-08-03 DAR

### 1/4 RATIO DECAY CYCLE

Figure 8-1. Ratio Decay Cycle

## Controller Field Tuning Procedure

1. Have the process steady state on manual control at the normal set point. It is important that, for the duration of the controller tuning operation, no load changes take place. The occurrence of a load change may cause a misinterpretation of the recorder trace. Turn the integral adjustment to the position of low reset response, that is, place the reset adjustment at 0.02 repeats per minute (or 50 minutes per repeat). Adjust the Proportional Gain to a fairly low setting. (The actual value of the Proportional Gain will depend on the type of process variable being controlled.) Leave it this way until you are sure that the process has reached steady state.
2. Turn the Integral adjustment to minimum Reset effect; this will reduce or eliminate the Integral function. Check to see that Derivative adjustment is set for minimum Derivative, or in Woodward controllers at an SDR of 100.
3. Switch to automatic control. Make a small change\* in the set point and observe the response of the process to the Proportional Gain setting. If little or no cycling takes place, increase the Proportional Gain to 150% of its previous value and make another small change to the set point. After each set point change, increase the Proportional Gain to twice its previous value until an "Optimum Proportional" response curve (see below) is obtained. If a change in Proportional produces a "Proportional Too High" curve (see below), lower the Proportional Gain to its previous setting. The "Proportional Too Low" curve illustrates the condition in which the proportional is too low.

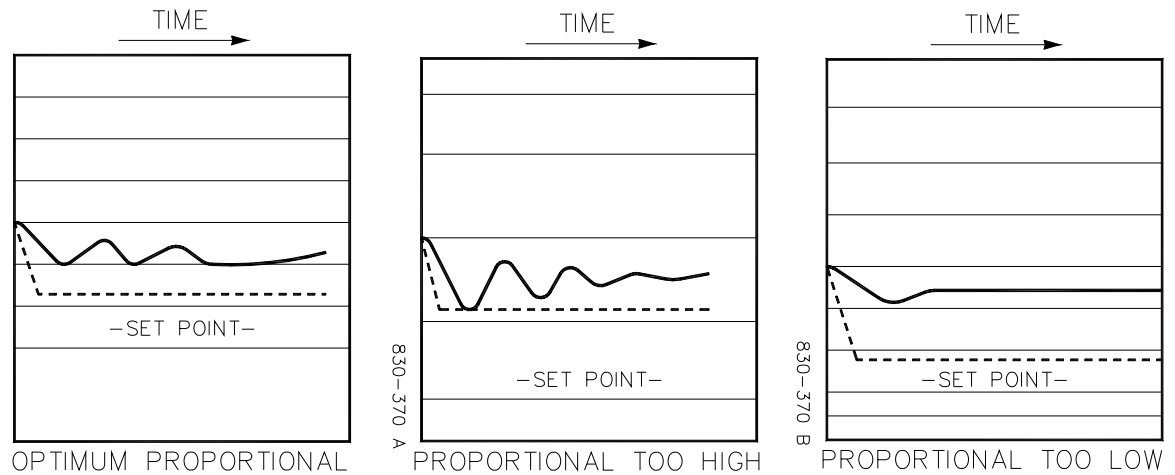

830-370  
92-08-05 DAR

Figure 8-2. Proportional Gain Settings

\*Set point changes can be made either up or down scale. The second change should return the set point to its original setting. Repeat this pattern through the tuning procedure.

4. With the Proportional Gain at the setting previously obtained in step 3, make a change in set point and observe the recovery cycle. If there is no excessive cycling, increase the Integral to 0.04 repeats per minute (or 25 minutes per repeat). Make another set point change and observe results. After each set point change, make a change in the Integral adjustment to increase the Integral by 50% of the previous Integral effect. Continue in this manner until an acceptable response curve is obtained.

## Accel/Decel Curves Setup

The GTC190 requires the user to configure an acceleration limiting curve and a deceleration limiting curve. The forcing function of this curve is the CDP signal. The output is a fuel valve position demand that equals the maximum (for Accel) or minimum (for Decel) fuel flow allowed for a given CDP. The information below will assist the user in programming these parameters in the service category. There are separate schedules for both gas and liquid fuels. For each curve, a maximum of five pairs (x,y) of data points can be defined. Any unused curve points should be at the end of the schedule and tuned out of the way (max CDP, 100).

### **IMPORTANT**

**Note on all Curves in the GTC Products—The control software will not allow the user to tune X values (inputs) of curves to a value equal to or higher than the point above it, or equal to or lower than the point below it. This is to protect the curve block from calculating infinite slopes that could cause problems during block runtime execution.**

**CDP Accel Schedule (Service-CDP to Fuel Limit Curve)**—The curve-defined acceleration rate limiter based on CDP scaled in same units as above. Outputs are scaled from 0 to 100% of valve travel. Since gas flow is not proportional to actuator current or valve angle, the Accel Schedule breakpoints should be calculated based on fuel flow and then fuel flow converted to actuator current using valve test data.

Note on completing Accel and Decel Schedules: Gas flow in pph or BTU/hr vs. actuator current data is required. Also required are the turbine manufacturer's acceleration and deceleration specifications.

1. Plot a piece-wise linear approximation to the required accel and decel schedules with four slopes maximum for accel and decel. This plot determines the breakpoints in the schedules entered into the AtlasPC Digital Control System. Note that line slopes established by the schedule points do not change to zero at endpoints. If actuator current is to be held constant for varying CDP then a zero slope line segment must be created in the schedule.
2. Rescale the dependent variable (gas mass flow or heat consumption) to match the units used in the gas flow data.
3. Now plot the valve test data with the dependent variable scaled as above vs. actuator current. For greatest accuracy, a non-linear curve fit of the data should be used, however a piece-wise linear plot is generally acceptable.
4. Using the Y axis (gas flow) values of the endpoints and breakpoints from the plot of step 1, determine the corresponding actuator current values, which produce those flows in the plot of step 3.
5. Find the X axis (CDP) values of the endpoints and breakpoints from the plot of step 1.
6. Rescale the actuator current values of step 4 on a scale of 0 to 100 corresponding to min. to max. stops on the valve. If desired, plot this normalized actuator current as a function of CDP. This is the schedule to be entered in the AtlasPC Digital Control System.

For example, see the linearized sample manufacturers specification, Figure 8-3, and the valve test data example Table 8-1.



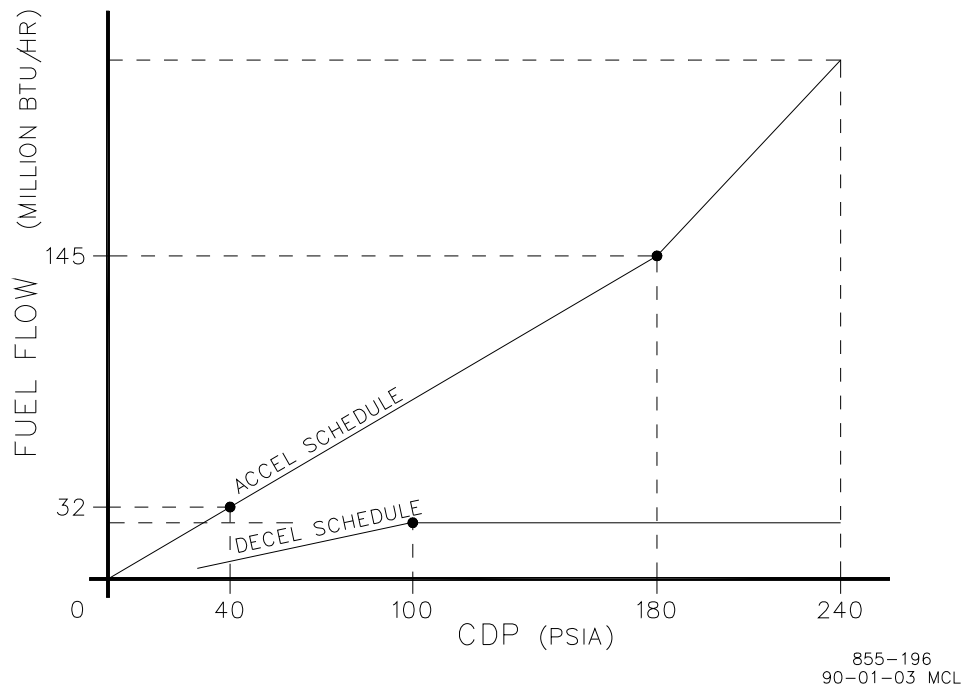

Figure 8-3. Linearized Flow Schedule

Valve Angle (deg)	Actuator Current (mA)	Gas Flow (pph)
9.0	32.8	435
9.8	35.0	515
16.5	54.7	1580
22.6	72.1	3060
28.0	86.3	4689
34.9	107.2	7059
41.8	127.7	9378
51.5	155.1	12488

Table 8-1. Valve Test Data

Given the gas lower heating value of 20 000 BTU/lbm, flow in million BTU/h can be rescaled for pph as in the valve test data. The accel schedule breakpoint is at 7250 pph (145 million BTU/h) fuel flow and 180 psia CDP. From the valve test data, this point corresponds to 108.9 mA of actuator current. For this example, a linear interpolation between valve test data points was used to find the actuator current (step 3 above). However, better accuracy would result using a non-linear curve fit. Two more points are required to establish the two-slope accel schedule. The first is (40 psia, 1600 pph) which corresponds to 54.9 mA. The second endpoint is (240 psia, 10500 pph) which corresponds to an actuator current of 137.6 mA. Now rescale actuator current for 0 to 100 for min. to max. travel of the valve. From the valve data, min. travel is at 35.0 mA and max travel is at 155.1 mA. This gives:

CDP (psia)	Act. Current (mA)	Act. Signal (0 to 100)
40	54.9	16.6
180	108.9	61.5
240	137.6	85.4

Where CDP is the Accel Schedule input value to be entered and ACT. SIGNAL is the output value to be entered. The same procedure is followed for the Decel Schedule.

DN/DT Accel Schedule is biased by GG speed derivative. When DN/DT PID control is used, the acceleration (or deceleration) schedule values must be in terms of GG speed (for inputs) and GG derivative (for outputs).

## Poor Valve Response

What can often appear as a tuning problem, is often poor valve response. This can be due to a sticky actuator or inconsistent hydraulic pressure to the actuator. Changing hydraulic oil properties can also have an adverse affect to the control of the turbine.

The hydraulic supply to the actuator must be a consistent pressure over the entire operating range of the turbine.

The AtlasPC Digital Control System does have logic built in to account for a sticky valve/actuator assembly. If you are having problems with the control of the turbine and the loops have been tuned and hydraulics verified, contact Woodward for service.

## Common SIO Port Configurations

The following is a guideline for configuring a serial port interface from the control to a communication device. Items **highlighted** are required.

	Control Assistant (Mimic/WinPanel)	Control Assistant (Tunables/Datalogs)	Modbus RTU	Eventlatch	ServLink and WatchWindow
<b>BAUD</b>	10 (38400)	10 (38400)	10 (38400)	10 (38400)	10 (38400)
<b>BITS</b>	2 (8 data)	2 (8 data)	<b>2 (RTU-8 bits)</b>	2 (8 data)	<b>2 (RTU-8 bits)</b>
<b>STOP</b>	1 (1 stop)	1 (1 stop)	1 (1 stop)	1 (1 stop)	1 (1 stop)
<b>PARITY</b>	1 (none)	1 (none)	1 (none)	1 (none)	1 (none)
<b>MODE</b>	<b>2 (char)</b>	1 (line)	1 (line)	<b>1 (line)</b>	1 (line)
<b>FLOW</b>	1 (off)	<b>1 (off)</b>	1 (off)	2 (xon-xoff)	1 (off)
<b>ECHO</b>	1 (off)	1 (off)	1 (off)	1 (off)	1 (off)
<b>ENDLINE</b>	3 (crlf)	3 (crif)	3 (crif)	3 (crif)	1 (lf)
<b>IGNCR</b>	2 (on)	2 (on)	1 (off)	1 (off)	1 (off)

Table 8-2. Valve Test Data

## Serial Null Modem Cable Reference

The following defines a standard null modem cable which can be purchased at any electronics store. This cable is useful for interfacing a Woodward control to a PC running Control Assistant, ServLink, or Watch Window.

Pinout Diagram for a 9 pin to 9 pin null modem cable:

(1-4, 2-3, 3-2, 4-6, 5-5, 6-4, 7-8, 8-7)

RD2	-----\	/-----	2RD	(pin 2 is tied to pin 3)
TD3	-----/	\-----	3TD	(pin 3 is tied to pin 2)
DTR4	-----	/ -----	4DTR	(pin 4 is tied to pin 1, then to 6
DCD1	----- \	/ -----	1DCD	on both sides)
DSR6	-----/	\-----	6DSR	(both are tied to pin 6)
SG5	-----		5SG	
RTS7	-----\	/-----	7RTS	(pin 7 is tied to pin 8)
CTS8	-----/	\-----	8CTS	(pin 8 is tied to pin 7)
RI9	-----	-----	9RI	(pins 9 and 9 are terminated)

### Pin Definitions

CTS	Clear To Send. The CTS line is asserted by the PC (as DCE device) when it is ready to receive data.
DCD	Data Carrier Detect. The DCD line is asserted when the data link is established.
DCE	Data Communications Equipment. Refers to the modem in a computer to modem setup.
DSR	Data Set Ready. The DSR line is asserted by the DCE when it is ready to communicate with the DTE.
DTE	Data Terminal Equipment. Refers to the computer in a computer to modem setup.
DTR	Data Terminal Ready. The DTR line is asserted by the DTE when it is ready to communicate with the DCE.
FG	Field Ground. A protective line used to ground the DCE.
RD	Receive Data. The RD line is used by the DCE to send data to the DTE.
RI	Ring Indicator. The RI line is asserted by the DCE when a ring is detected.
RTS	Request To Send. The RTS line is asserted by the DTE when it wants to transmit data to the DCE.
SG	Signal Ground. The common return (and voltage baseline) for the various signal lines.
TD	Transmit Data. The TD line is used by the DTE to send data to the DCE.

# Chapter 9.

## Service Options

### Product Service Options

If you are experiencing problems with the installation, or unsatisfactory performance of a Woodward product, the following options are available:

- Consult the troubleshooting guide in the manual.
- Contact the manufacturer or packager of your system.
- Contact the Woodward Full Service Distributor serving your area.
- Contact Woodward technical assistance (see “How to Contact Woodward” later in this chapter) and discuss your problem. In many cases, your problem can be resolved over the phone. If not, you can select which course of action to pursue based on the available services listed in this chapter.

**OEM and Packager Support:** Many Woodward controls and control devices are installed into the equipment system and programmed by an Original Equipment Manufacturer (OEM) or Equipment Packager at their factory. In some cases, the programming is password-protected by the OEM or packager, and they are the best source for product service and support. Warranty service for Woodward products shipped with an equipment system should also be handled through the OEM or Packager. Please review your equipment system documentation for details.

**Woodward Business Partner Support:** Woodward works with and supports a global network of independent business partners whose mission is to serve the users of Woodward controls, as described here:

- A **Full Service Distributor** has the primary responsibility for sales, service, system integration solutions, technical desk support, and aftermarket marketing of standard Woodward products within a specific geographic area and market segment.
- An **Authorized Independent Service Facility (AISF)** provides authorized service that includes repairs, repair parts, and warranty service on Woodward's behalf. Service (not new unit sales) is an AISF's primary mission.
- A **Recognized Engine Retrofitter (RER)** is an independent company that does retrofits and upgrades on reciprocating gas engines and dual-fuel conversions, and can provide the full line of Woodward systems and components for the retrofits and overhauls, emission compliance upgrades, long term service contracts, emergency repairs, etc.
- A **Recognized Turbine Retrofitter (RTR)** is an independent company that does both steam and gas turbine control retrofits and upgrades globally, and can provide the full line of Woodward systems and components for the retrofits and overhauls, long term service contracts, emergency repairs, etc.

A current list of Woodward Business Partners is available at [www.woodward.com/support](http://www.woodward.com/support).

## Woodward Factory Servicing Options

The following factory options for servicing Woodward products are available through your local Full-Service Distributor or the OEM or Packager of the equipment system, based on the standard Woodward Product and Service Warranty (5-01-1205) that is in effect at the time the product is originally shipped from Woodward or a service is performed:

- Replacement/Exchange (24-hour service)
- Flat Rate Repair
- Flat Rate Remanufacture

**Replacement/Exchange:** Replacement/Exchange is a premium program designed for the user who is in need of immediate service. It allows you to request and receive a like-new replacement unit in minimum time (usually within 24 hours of the request), providing a suitable unit is available at the time of the request, thereby minimizing costly downtime. This is a flat-rate program and includes the full standard Woodward product warranty (Woodward Product and Service Warranty 5-01-1205).

This option allows you to call your Full-Service Distributor in the event of an unexpected outage, or in advance of a scheduled outage, to request a replacement control unit. If the unit is available at the time of the call, it can usually be shipped out within 24 hours. You replace your field control unit with the like-new replacement and return the field unit to the Full-Service Distributor.

Charges for the Replacement/Exchange service are based on a flat rate plus shipping expenses. You are invoiced the flat rate replacement/exchange charge plus a core charge at the time the replacement unit is shipped. If the core (field unit) is returned within 60 days, a credit for the core charge will be issued.

**Flat Rate Repair:** Flat Rate Repair is available for the majority of standard products in the field. This program offers you repair service for your products with the advantage of knowing in advance what the cost will be. All repair work carries the standard Woodward service warranty (Woodward Product and Service Warranty 5-01-1205) on replaced parts and labor.

**Flat Rate Remanufacture:** Flat Rate Remanufacture is very similar to the Flat Rate Repair option with the exception that the unit will be returned to you in “like-new” condition and carry with it the full standard Woodward product warranty (Woodward Product and Service Warranty 5-01-1205). This option is applicable to mechanical products only.

## Returning Equipment for Repair

If a control (or any part of an electronic control) is to be returned for repair, please contact your Full-Service Distributor in advance to obtain Return Authorization and shipping instructions.

When shipping the item(s), attach a tag with the following information:

- return number;
- name and location where the control is installed;
- name and phone number of contact person;
- complete Woodward part number(s) and serial number(s);
- description of the problem;
- instructions describing the desired type of repair.

## Packing a Control

Use the following materials when returning a complete control:

- protective caps on any connectors;
- antistatic protective bags on all electronic modules;
- packing materials that will not damage the surface of the unit;
- at least 100 mm (4 inches) of tightly packed, industry-approved packing material;
- a packing carton with double walls;
- a strong tape around the outside of the carton for increased strength.

### **NOTICE**

To prevent damage to electronic components caused by improper handling, read and observe the precautions in Woodward manual 82715, *Guide for Handling and Protection of Electronic Controls, Printed Circuit Boards, and Modules*.

## Replacement Parts

When ordering replacement parts for controls, include the following information:

- the part number(s) (XXXX-XXXX) that is on the enclosure nameplate;
- the unit serial number, which is also on the nameplate.

## Engineering Services

Woodward offers various Engineering Services for our products. For these services, you can contact us by telephone, by email, or through the Woodward website.

- Technical Support
- Product Training
- Field Service

**Technical Support** is available from your equipment system supplier, your local Full-Service Distributor, or from many of Woodward's worldwide locations, depending upon the product and application. This service can assist you with technical questions or problem solving during the normal business hours of the Woodward location you contact. Emergency assistance is also available during non-business hours by phoning Woodward and stating the urgency of your problem.

**Product Training** is available as standard classes at many of our worldwide locations. We also offer customized classes, which can be tailored to your needs and can be held at one of our locations or at your site. This training, conducted by experienced personnel, will assure that you will be able to maintain system reliability and availability.

**Field Service** engineering on-site support is available, depending on the product and location, from many of our worldwide locations or from one of our Full-Service Distributors. The field engineers are experienced both on Woodward products as well as on much of the non-Woodward equipment with which our products interface.

For information on these services, please contact us via telephone, email us, or use our website and reference [www.woodward.com/support](http://www.woodward.com/support), and then **Customer Support**.

## How to Contact Woodward

For assistance, call one of the following Woodward facilities to obtain the address and phone number of the facility nearest your location where you will be able to get information and service.

<b>Electrical Power Systems</b>		<b>Engine Systems</b>		<b>Turbine Systems</b>	
<b>Facility</b>	<b>Phone Number</b>	<b>Facility</b>	<b>Phone Number</b>	<b>Facility</b>	<b>Phone Number</b>
Australia	+61 (2) 9758 2322	Australia	+61 (2) 9758 2322	Australia	+61 (2) 9758 2322
Brazil	+55 (19) 3708 4800	Brazil	+55 (19) 3708 4800	Brazil	+55 (19) 3708 4800
China	+86 (512) 6762 6727	China	+86 (512) 6762 6727	China	+86 (512) 6762 6727
Germany:		Germany:			
Kempen	+49 (0) 21 52 14 51	Stuttgart	+49 (711) 78954-0		
Stuttgart	+49 (711) 78954-0	India	+91 (129) 4097100	India	+91 (129) 4097100
India	+91 (129) 4097100	Japan	+81 (43) 213-2191	Japan	+81 (43) 213-2191
Japan	+81 (43) 213-2191	Korea	+82 (51) 636-7080	Korea	+82 (51) 636-7080
Korea	+82 (51) 636-7080	The Netherlands	+31 (23) 5661111	The Netherlands	+31 (23) 5661111
Poland	+48 12 618 92 00				
United States	+1 (970) 482-5811	United States	+1 (970) 482-5811	United States	+1 (970) 482-5811

You can also contact the Woodward Customer Service Department or consult our worldwide directory on Woodward's website ([www.woodward.com/support](http://www.woodward.com/support)) for the name of your nearest Woodward distributor or service facility.

For the most current product support and contact information, please refer to the latest version of publication 51337 at [www.woodward.com/publications](http://www.woodward.com/publications).

## Technical Assistance

If you need to telephone for technical assistance, you will need to provide the following information. Please write it down here before phoning:

### General

Your Name \_\_\_\_\_  
Site Location \_\_\_\_\_  
Phone Number \_\_\_\_\_  
Fax Number \_\_\_\_\_

### Prime Mover Information

Engine/Turbine Model Number \_\_\_\_\_  
Manufacturer \_\_\_\_\_  
Number of Cylinders (if applicable) \_\_\_\_\_  
Type of Fuel (gas, gaseous, steam, etc) \_\_\_\_\_  
Rating \_\_\_\_\_  
Application \_\_\_\_\_

### Control/Governor Information

Please list all Woodward governors, actuators, and electronic controls in your system:

Woodward Part Number and Revision Letter

Control Description or Governor Type

Serial Number

Woodward Part Number and Revision Letter

Control Description or Governor Type

Serial Number

Woodward Part Number and Revision Letter

Control Description or Governor Type

Serial Number

*If you have an electronic or programmable control, please have the adjustment setting positions or the menu settings written down and with you at the time of the call.*



# Appendix A.

## System Input/Output Signal Layout

Control wiring diagram 9971-1160 is on the next pages.

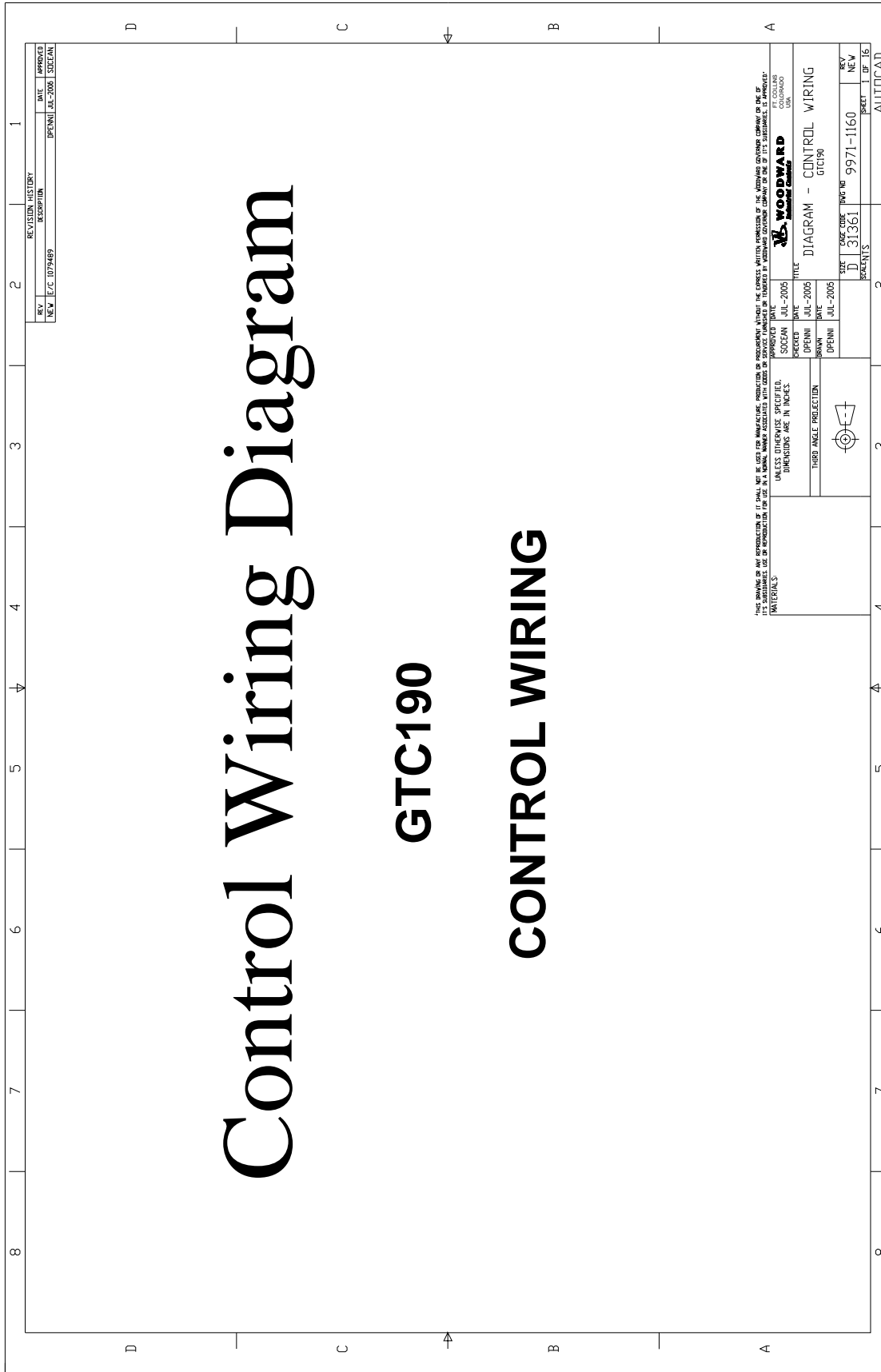

# Control Wiring Diagram

## GTC190

### CONTROL WIRING

REV	DESCRIPTION	DATE	APPROVE
NEW	E/C 1074489	JUL-2005	SDCEAN

REVISION HISTORY

THIS DRAWING OR ITS REPRODUCTION IS TO BE USED FOR MANUFACTURE, PRODUCTION OR REPRODUCTION WITHOUT THE EXPRESS WRITTEN PERMISSION OF THE MANUFACTURER OR OWNER. ANY REUSE OF THIS DRAWING OR ITS REPRODUCTION FOR ANY OTHER PURPOSE IS STRICTLY PROHIBITED. UNLESS OTHERWISE SPECIFIED, DIMENSIONS ARE IN INCHES.

WOODWARD  
 Woodward Controls  
 10000  
 10000  
 10000

APPROVED DATE: JUL-2005  
 DRAWN: JUL-2005  
 CHECKED: JUL-2005  
 TITLE: DIAGRAM - CONTROL WIRING  
 GTC190

THIRD ANGLE PROJECTION  



SIZE: D  
 CASE CODE: 31361  
 DRAWING NO: 9971-1160  
 REV: NEW  
 SHEET: 1 OF 16

AUTOCAD

SHEET NUMBER	DESIGNATION	DESCRIPTION	REV. DATE
SHEET 1	COVER	COVER SHEET	JUL-2005
SHEET 2	INDEX	SHEET INDEX SHEET	JUL-2005
SHEET 3	CHASSIS LAYOUT	ATLAS CHASSIS	JUL-2005
SHEET 4	PS BOARD	POWER & DISCRETE OUTPUTS	JUL-2005
SHEET 5	A02 SMARTCORE1	DISCRETE INPUTS	JUL-2005
SHEET 6	A02 SMARTCORE2	ANALOG INPUTS & SPEED INPUTS	JUL-2005
SHEET 7	A02 SMARTCORE3	ANALOG OUTPUTS AND ACTUATOR OUTPUTS	JUL-2005
SHEET 8	A02 SMARTCORE4	COMMUNICATION PORTS	JUL-2005
SHEET 9	A03 POWERSENSE1	LOAD BUS PT/CT's AND VOLTAGE/SPEED BIAS OUTPUTS	JUL-2005
SHEET 10	A03 POWERSENSE2	GENERATOR PT/CT's AND LON/CAN COMMUNICATIONS	JUL-2005
SHEET 11	A04 ANALOGCOMB01	T/C INPUTS & ANALOG INPUTS	JUL-2005
SHEET 12	A04 ANALOGCOMB02	ANALOG OUTPUTS & SPEED SIGNAL INPUTS	JUL-2005
SHEET 13	A05 ANALOGCOMB01	T/C INPUTS & ANALOG INPUTS	JUL-2005
SHEET 14	A05 ANALOGCOMB02	ANALOG OUTPUTS & SPEED SIGNAL INPUTS	JUL-2005
SHEET 15	FUEL DRIVERS	INTERFACE TO SFC DRIVERS (DEVICENET COMM)	JUL-2005
SHEET 16	DISTRIBUTED IO	ALLEN-BRADLEY FLEX IO (PROF BUS COMM)	JUL-2005

**NOTES:**

- 1) Descriptions with an asterisk are fixed I/O points that are required by the GTC190.
- 2) All other I/O points are configurable to be used as shown or reprogrammed via customer programming.
- 3) Each of the 2 Analog Combo boards is configured in the following manner:  
 Channels 1-10 Thermocouple Input  
 Channels 11-15 Analog 4-20 mA Input

 <b>WOODWARD</b> A DIVISION OF GEORGE FISHER ELECTRIC CORP. WILSONVILLE, OR, USA	
TITLE DIAGRAM - CONTROL WIRING GTC190	
SIZE D 31361	DRAWING NO 9971-1160
REVISIONS SHEET 2 OF 16	REV NEW
AUTOCAD	

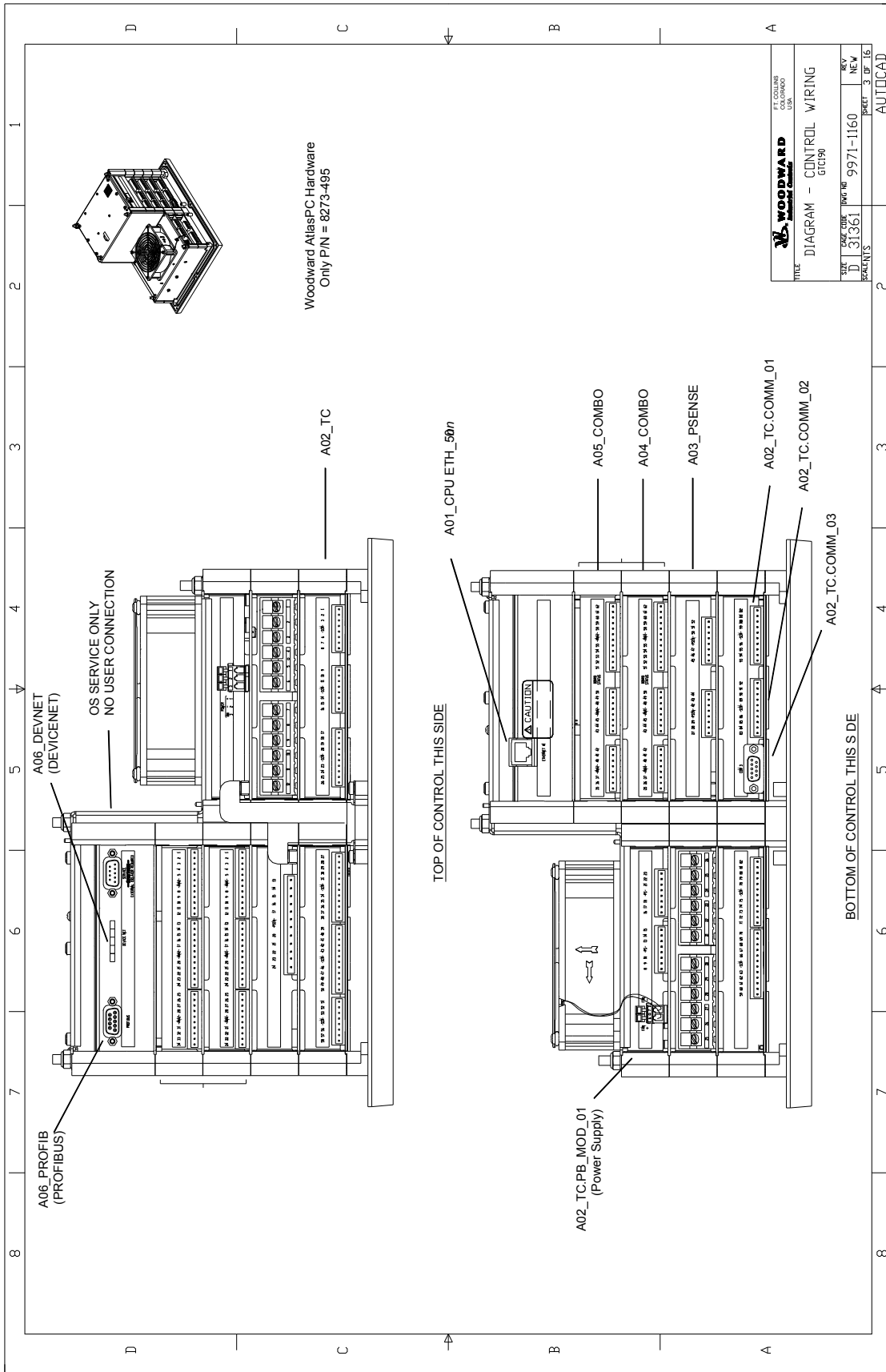



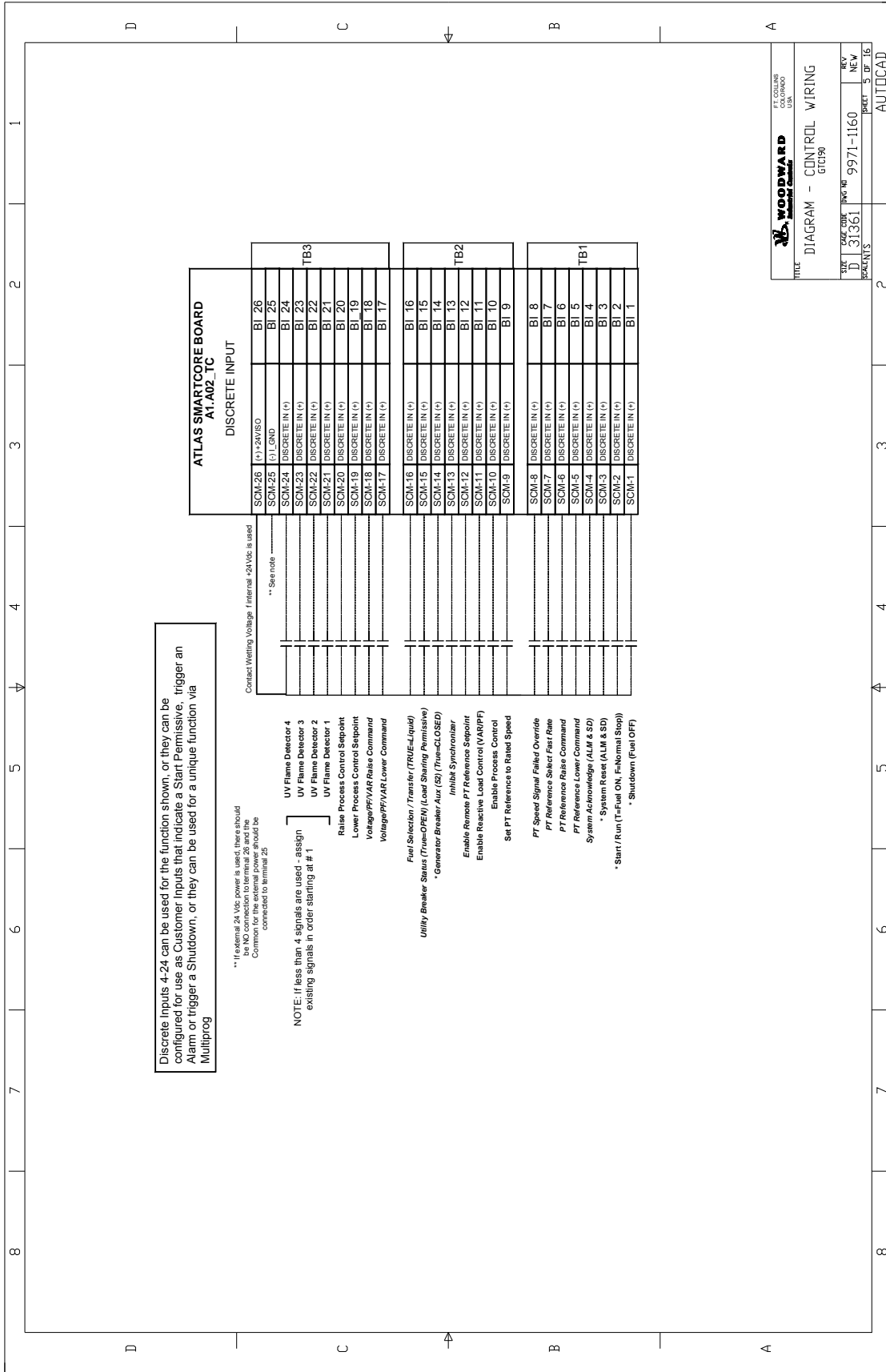

**WOODWARD**  
CORPORATION  
5000 WEST 120TH AVENUE  
DENVER, CO 80231 USA

TITLE: DIAGRAM - CONTROL WIRING  
GTC190

SIZE: D 31361  
DATE: 09/11/00  
REV: NEW

SHEET: 5 OF 16  
PROJECT: AUTOCAD

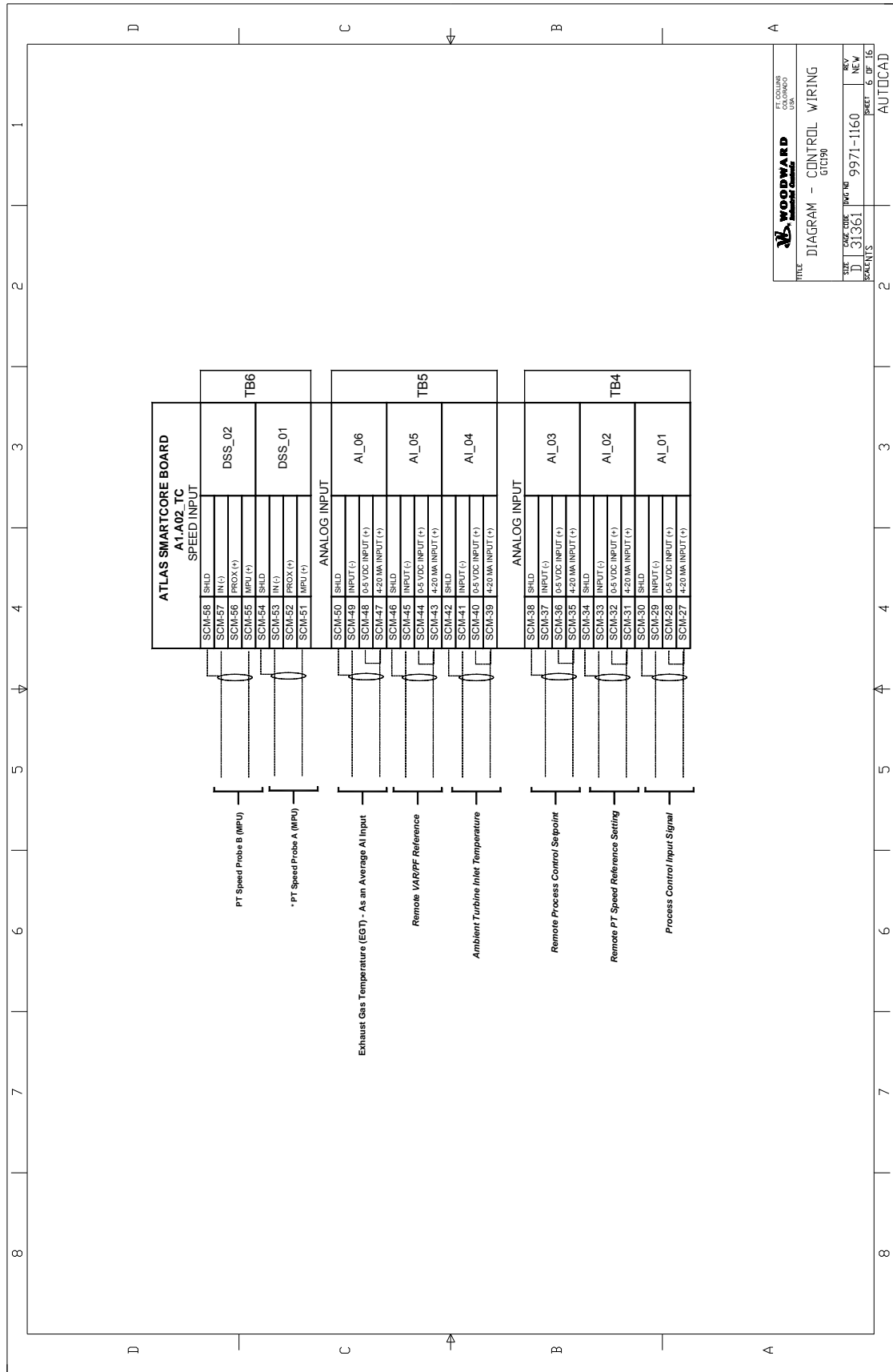

**WOODWARD**  
 1000 Woodward Drive  
 Golden, CO 80401  
 U.S.A.

TITLE: DIAGRAM - CONTROL WIRING  
 GTC190

SIZE: D 31361  
 CASE CODE: 9971-1160  
 REV: NEW

SHEET: 6 OF 16  
 AUTOCAD

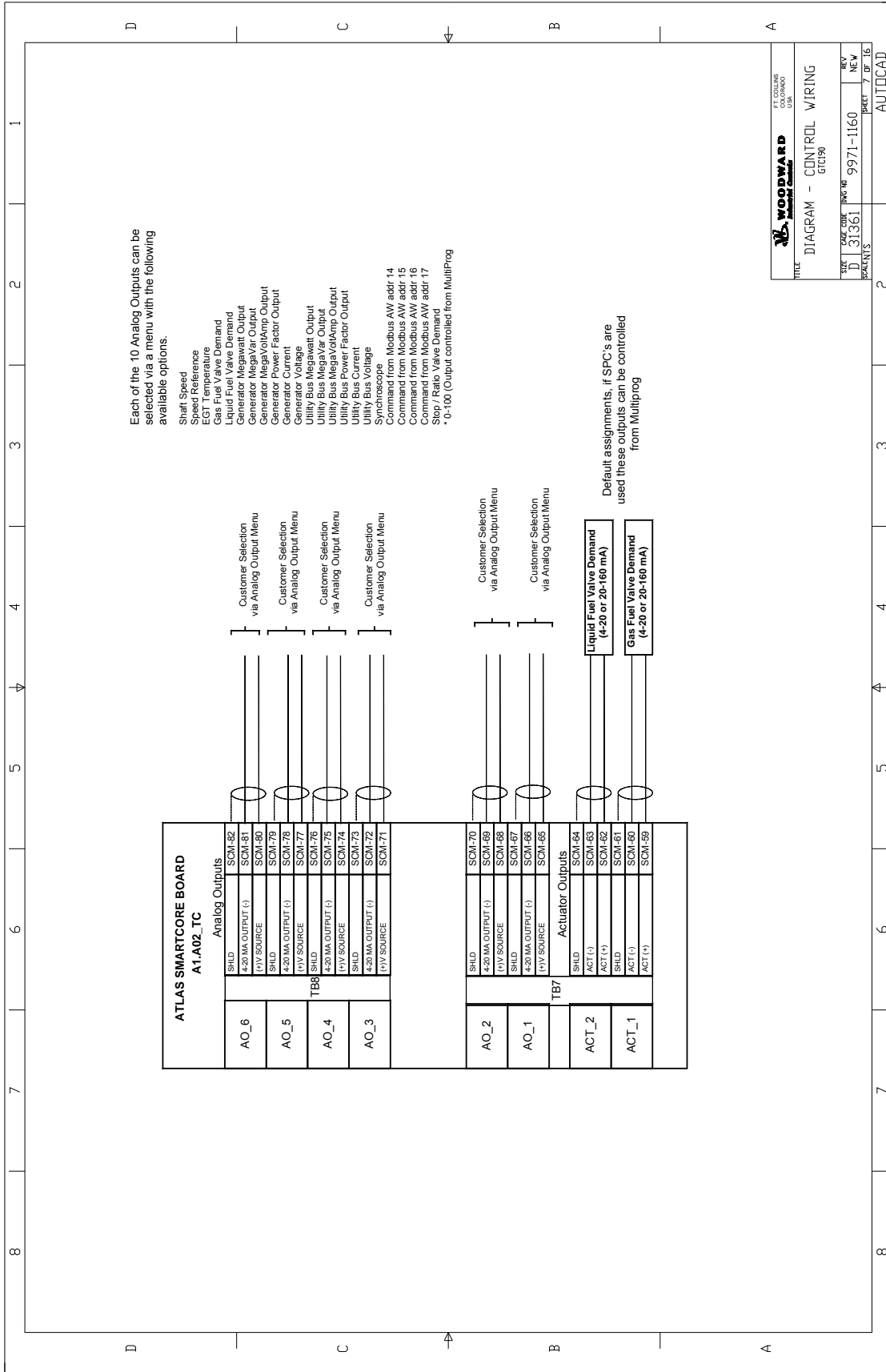

Each of the 10 Analog Outputs can be selected via a menu with the following available options.

- Shield Speed Reference
- EGT Temperature
- Gas Fuel Valve Demand
- Liquid Fuel Valve Demand
- Generator Megawatt Output
- Generator MegaVar Output
- Generator Power Factor Output
- Generator Current
- Utility Bus MegaVar Output
- Utility Bus Megawatt Output
- Utility Bus MegaVar Output
- Utility Bus Power Factor Output
- Utility Bus Current
- Utility Bus Voltage
- Synchroscope
- Command from Modbus AW addr 14
- Command from Modbus AW addr 15
- Command from Modbus AW addr 16
- Command from Modbus AW addr 17
- Stop / Ratio Valve Demand
- \* 0-100 (Output controlled from MultiProg)

Default assignments, if SPC's are used these outputs can be controlled from MultiProg

**WOODWARD**  
WOODWARD  
 CONTROL SYSTEMS  
 USA

TITLE: **DIAGRAM - CONTROL WIRING**  
 GTC190

SIZE	D	DATE CODE	31361	HWG. NO.	9971-1160	REV.	NEW
SHEET 7 OF 16						AUTOCAD	



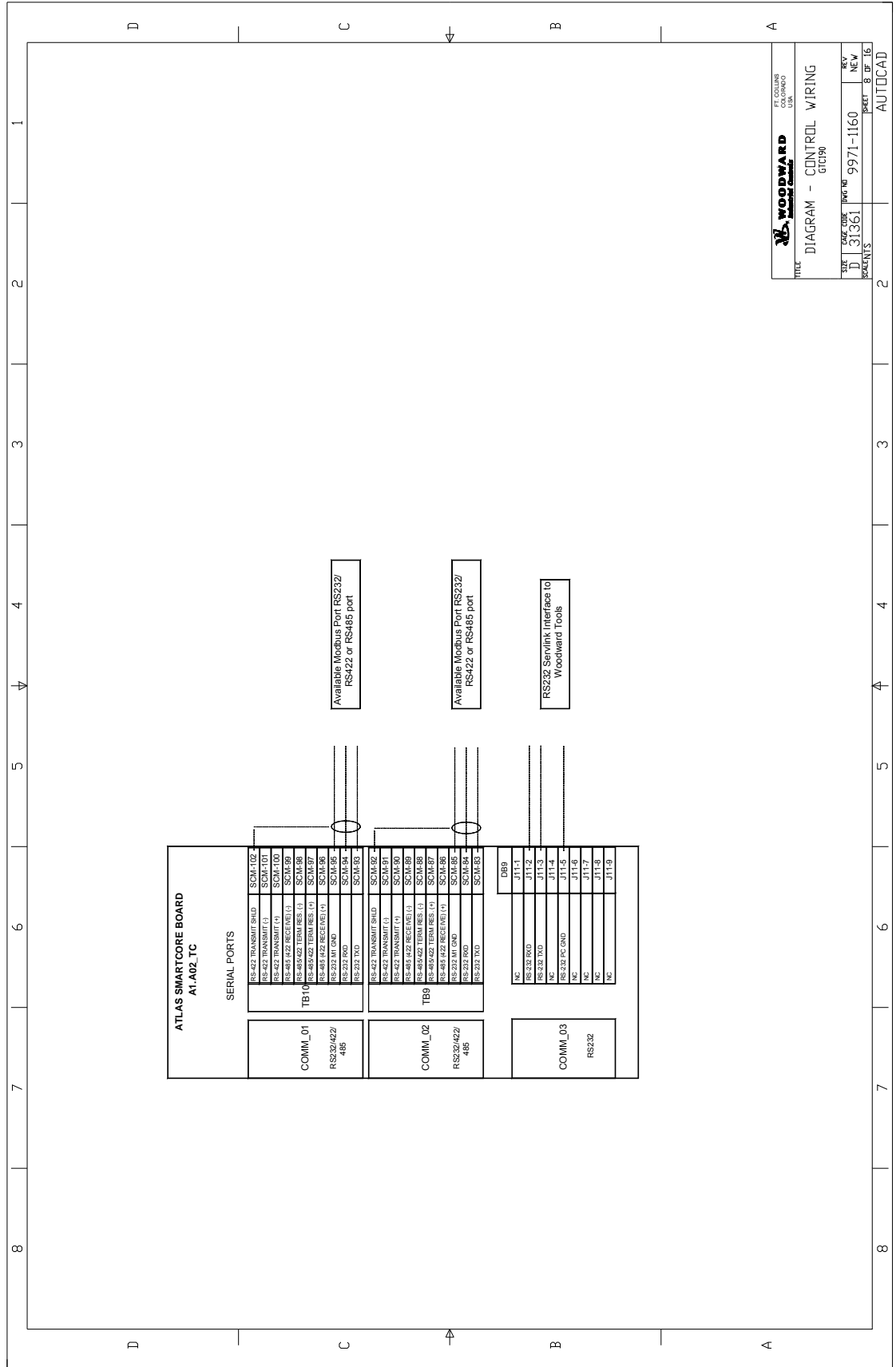

**WOODWARD**  
CORPORATION  
5000 WEST 130TH AVENUE  
BENTON, COLO. 80015  
U.S.A.

TITLE: DIAGRAM - CONTROL WIRING  
GTC190

SIZE	DATE CODE	ISSUE NO	REV
D	31361	9971-1160	NEW

PACKET: B OF 16  
AUTOCAD

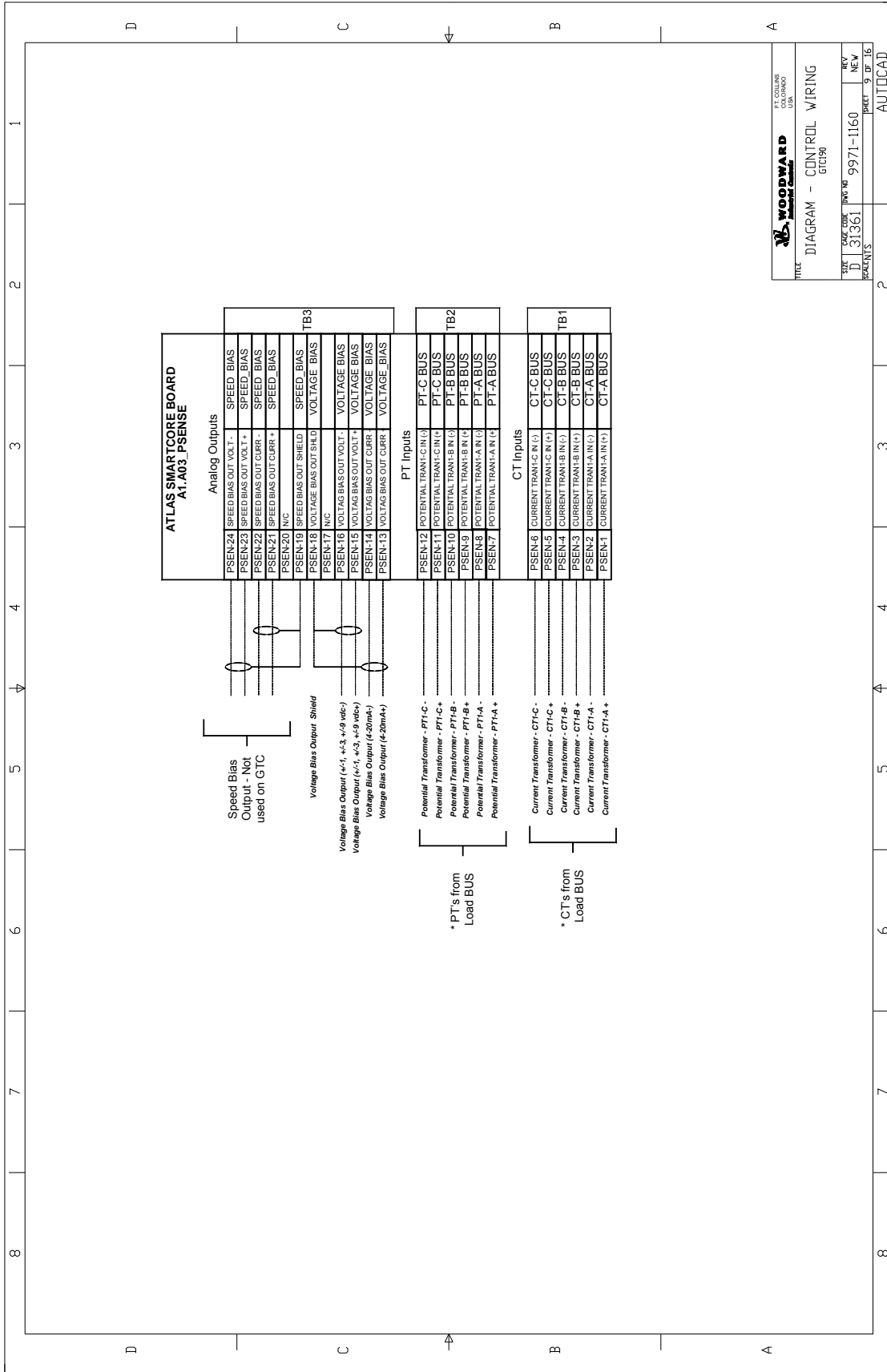

**WOODWARD**  
CORPORATION  
500 WEST 17TH AVENUE  
DENVER, CO 80202-2700  
USA

TITLE: DIAGRAM - CONTROL WIRING  
GTC190

SIZE	D	DATE CODE	9971-1160	REV	NEW
PAGES	1	NO. OF PAGES	16	PKET	9 OF 16

AUTOCAD

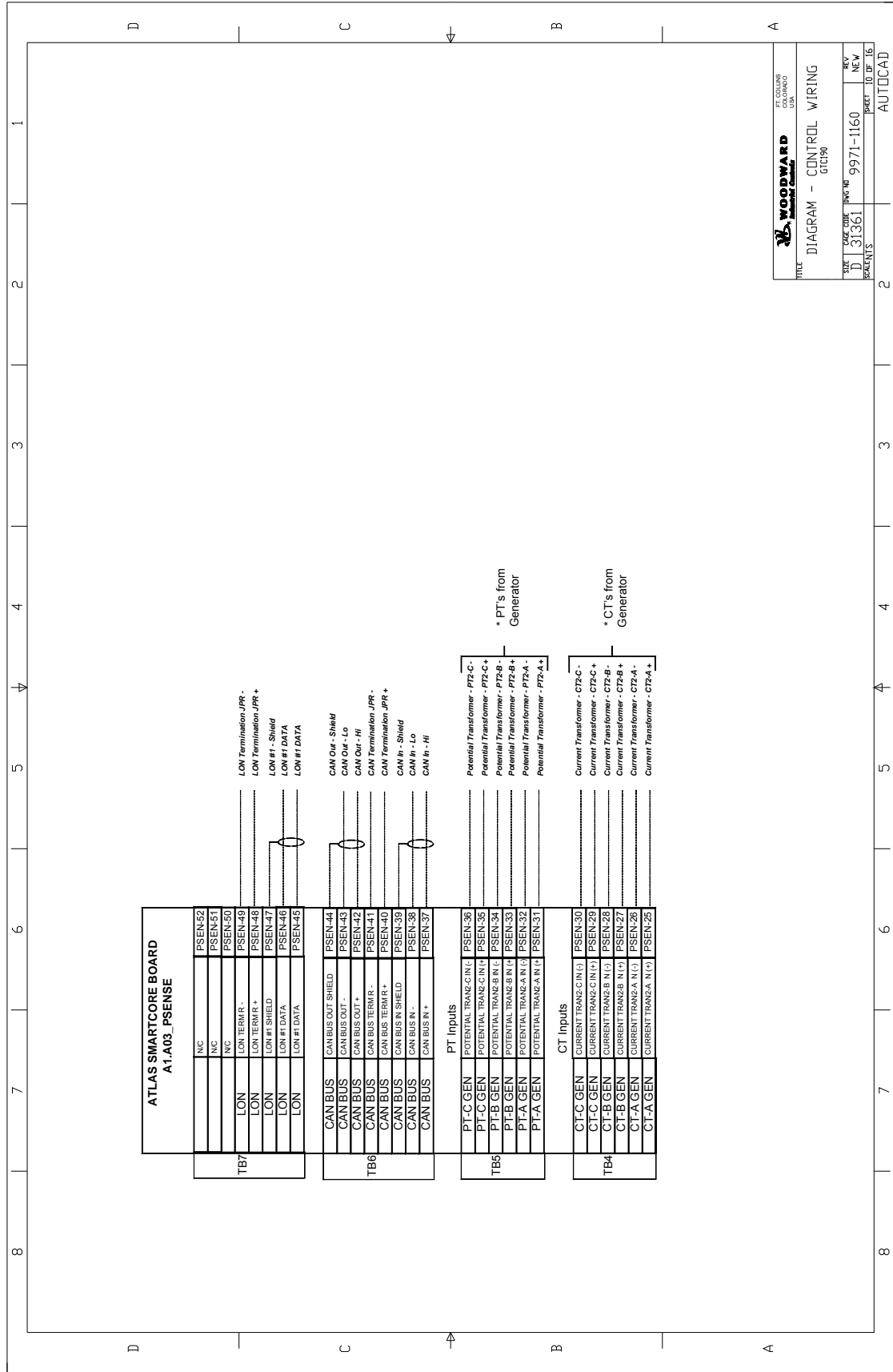

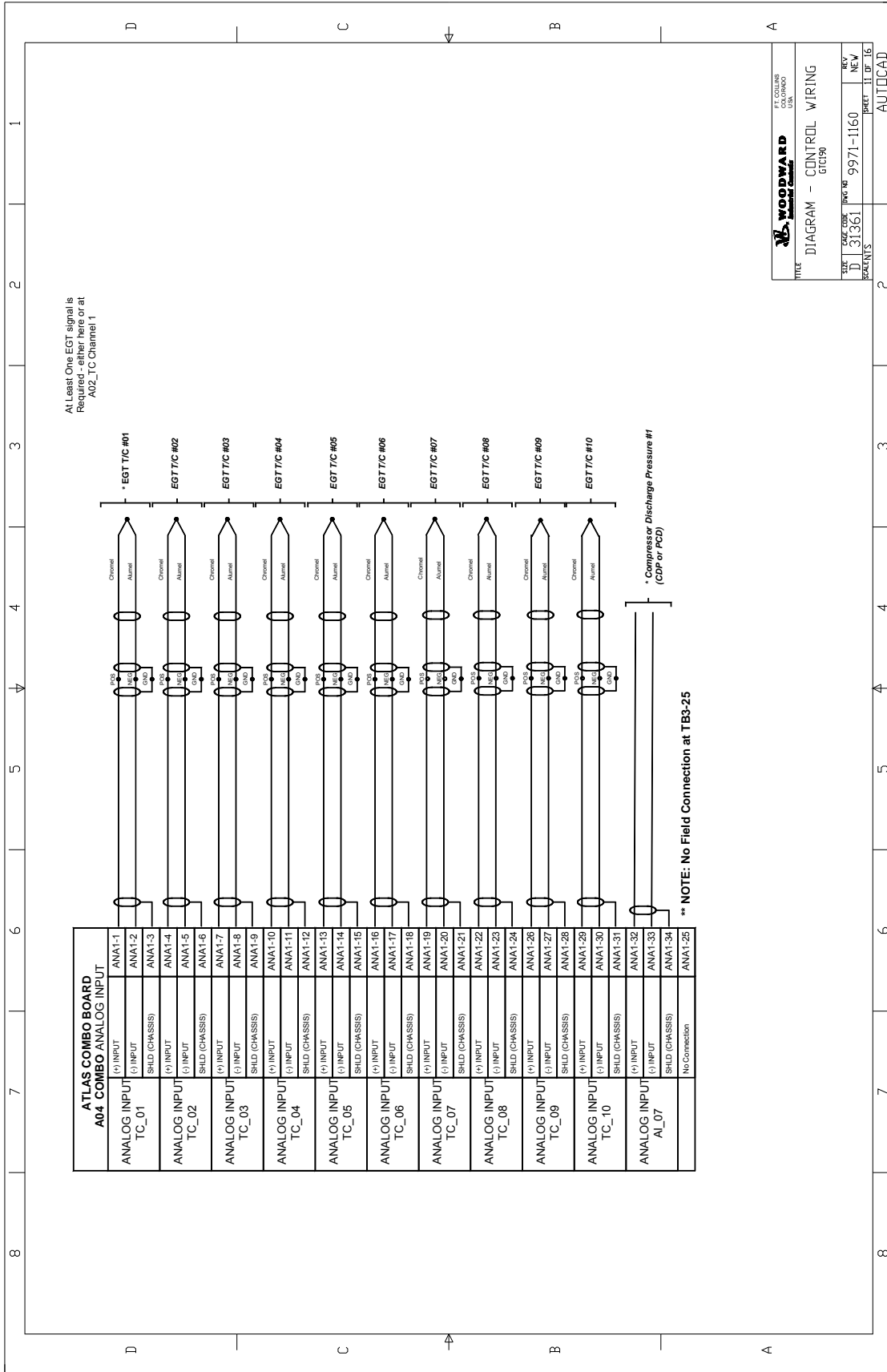

**WOODWARD**  
CORPORATION  
5000 WOODWARD DRIVE  
MILWAUKEE, WI 53212 USA

TITLE: DIAGRAM - CONTROL WIRING  
GTC190

SIZE	DATE	CODE	ISSUE NO	REV
D			31361	9971-1160

REVISIONS: 11 OF 16  
AUTOCAD

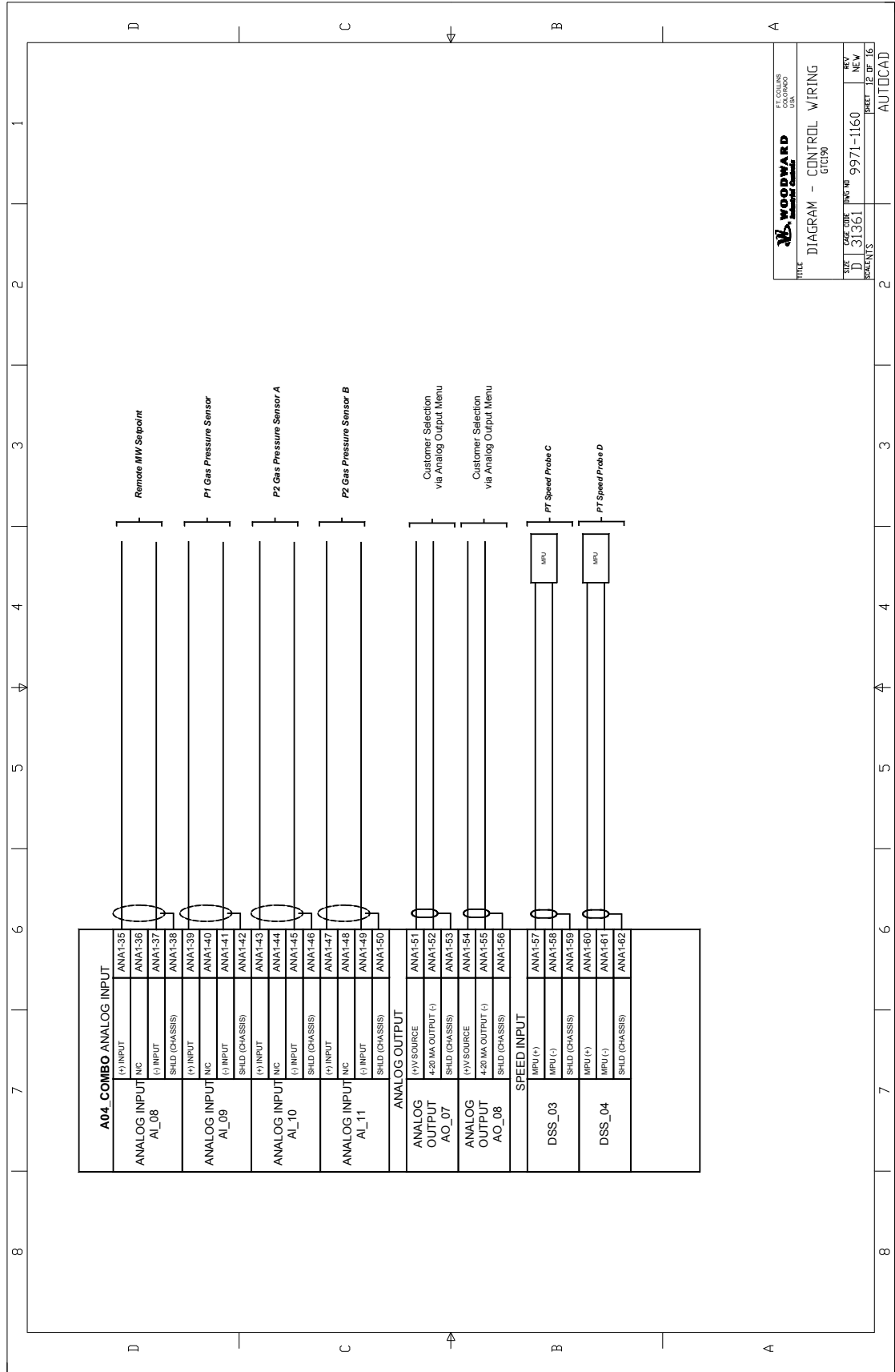

**WOODWARD**  
 11000 WOODWARD DRIVE  
 CLARK COUNTY, NV  
 USA

TITLE: **DIAGRAM - CONTROL WIRING**  
 GTC190

SIZE	DATE CODE	ISSUE NO	REV
D	31361	9971-1160	NEW

PERCENTS: 12 OF 16  
 AUTOCAD

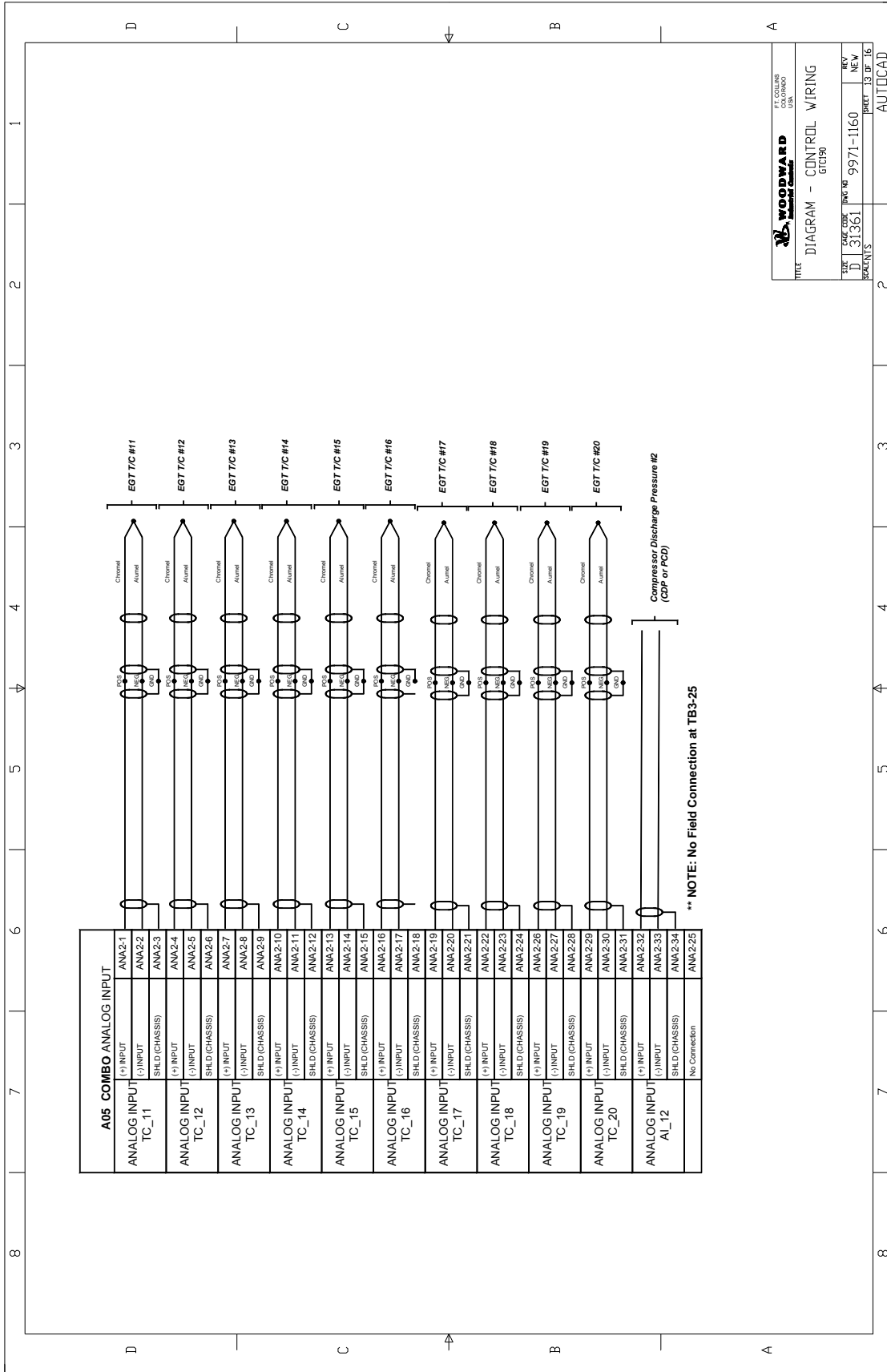

**WOODWARD**  
CORPORATION  
500 WEST 10TH AVENUE  
DENVER, CO 80202  
USA

TITLE: DIAGRAM - CONTROL WIRING  
GTC190

SIZE	DATE CODE	ISSUE NO	REV
D	31361	9971-1160	NEW

PAGE 13 OF 16  
AUTOCAD

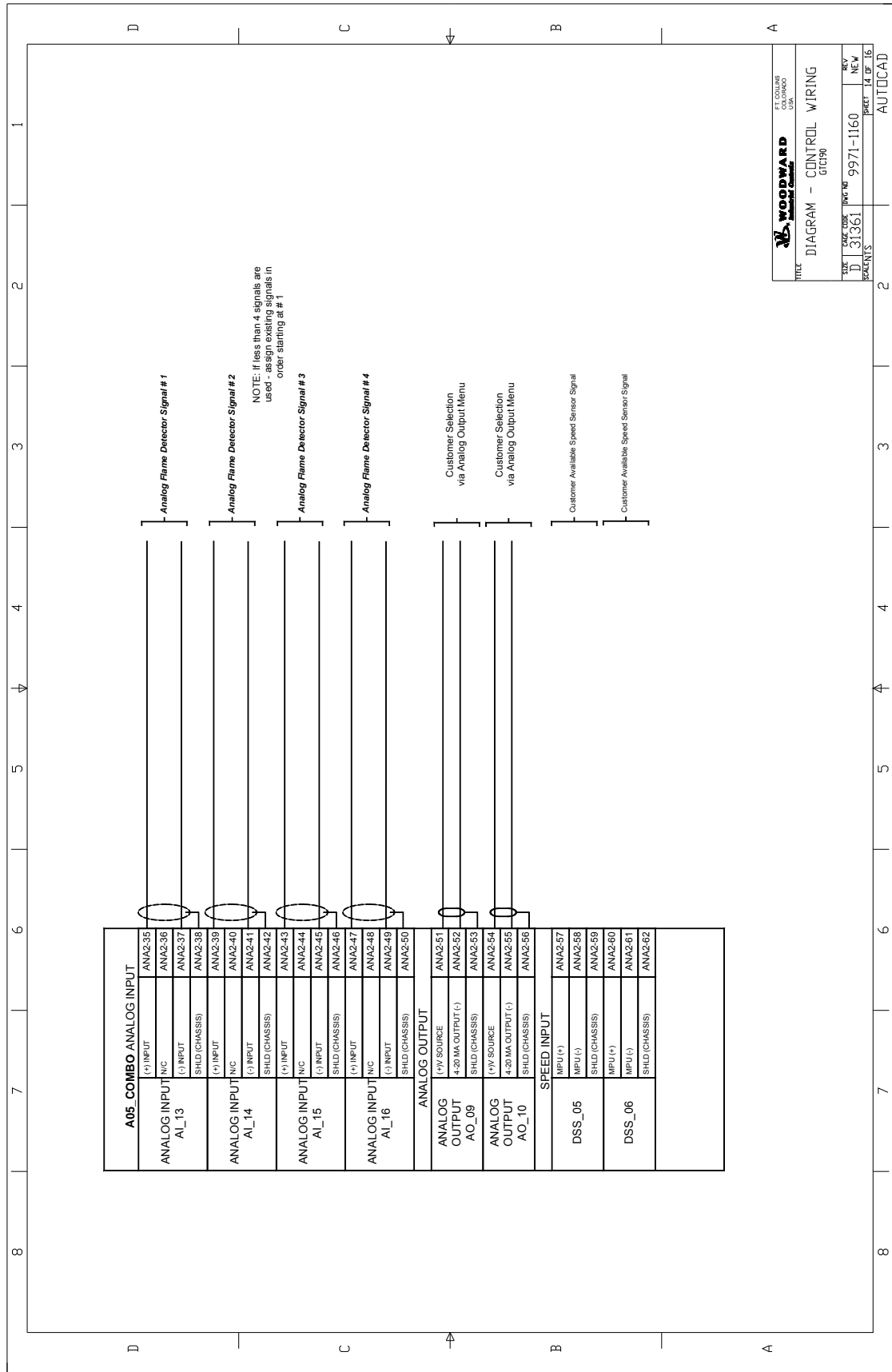

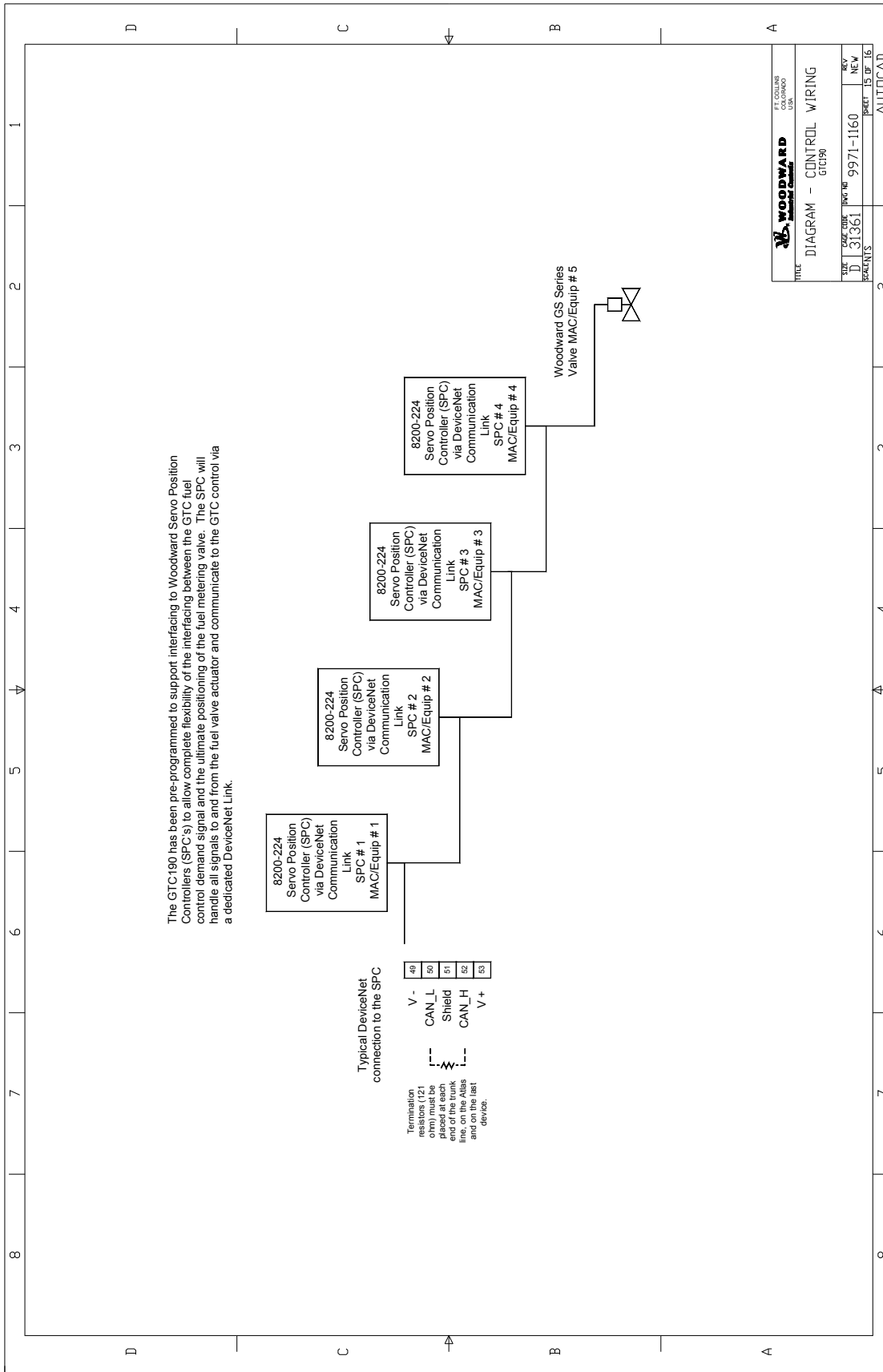



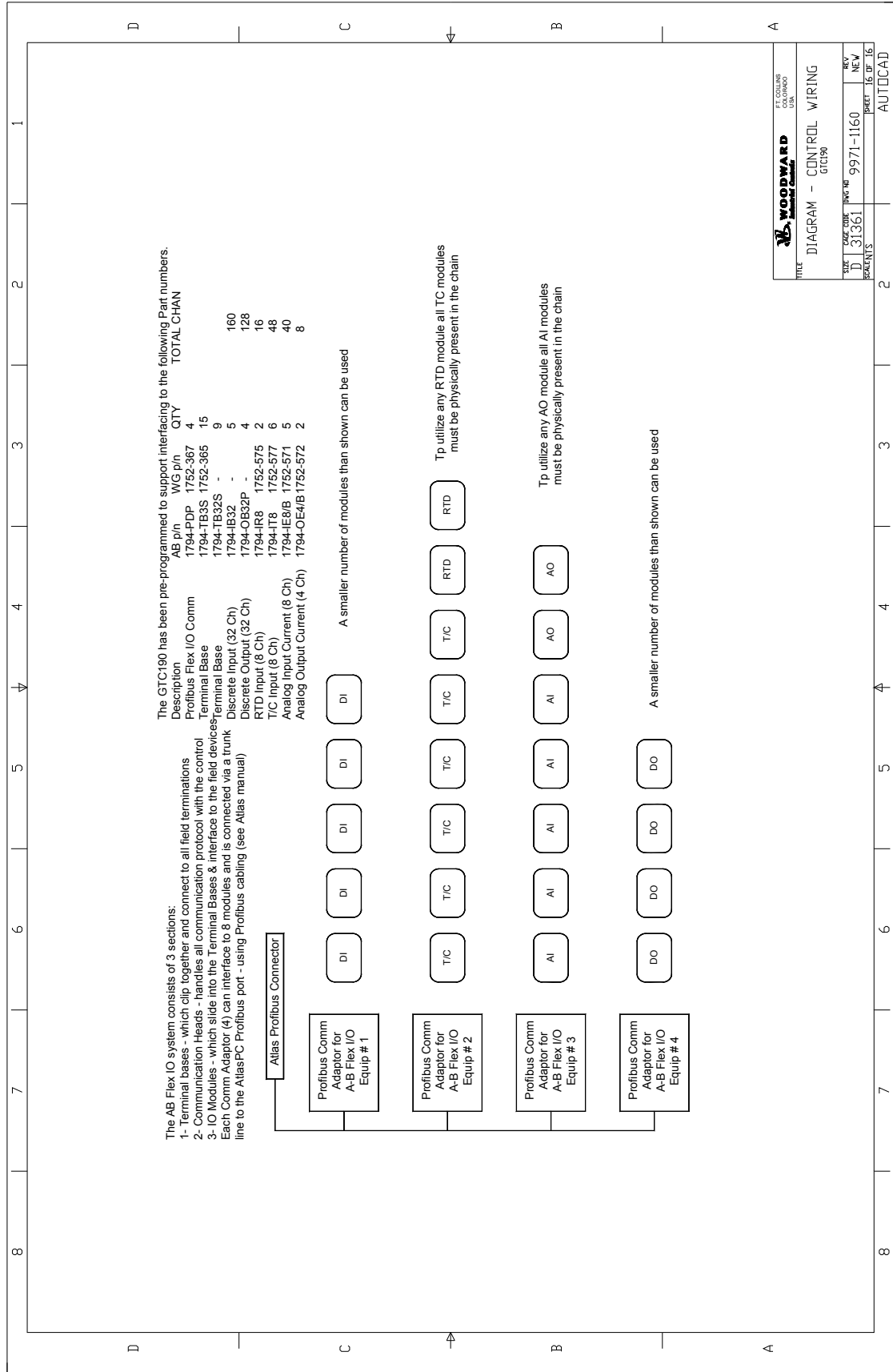

## Appendix B. Modbus List

The following is the Modbus List generated from the Application software. This information is sent out from the control in 2 Modbus blocks (LOCAL and REMOTE). These can be output on a variety of communication channels (max of 2 ports to each Modbus block) – serial ports COM1 and COM2, and on Ethernet ports 5002, 5003, 5004, 5005 (UDP) and ports 5006 & 5007 (TCP).

WOODWARD GOVERNOR COMPANY  
INDUSTRIAL CONTROLS DIVISION  
FORT COLLINS, COLORADO, U.S.A.

Woodward MODBUS Slave Address Information

FileName: 5418-2359.GAP                      File created on 08/23/05                      Rev: NEW  
P/N: 5418-2359                      Project: 82645  
GAP 2.16 / CODER 3.06  
GTC190 MASTER SECOND RING GAP FILE  
W/ INTERFACES TO DISTRIB IO & MULTIPROG

MODBUS\_S Block Name : MODBUS\_COM.MOD\_LOC and MODBUS\_COM.MOD\_REM

Boolean Writes (RPTbw)

Addr	Input	Description
0:0001		SHUTDOWN
0:0002		START
0:0003		RESET
0:0004		ACKNOWLEDGE
0:0005		SPEED REF LOWER
0:0006		SPEED REF RAISE
0:0007		SPD FAST RATE SELECT
0:0008		SPEED SIGNAL OVERRIDE
0:0009		SET REF TO RATED SPD
0:0010		ENABLE PROCESS CONTROL
0:0011		ENABLE VAR/PF CONTROL
0:0012		ENABLE REM PT REFERENCE
0:0013		INHIBIT SYNCHRONIZER
0:0014		GEN BREAKER STATUS
0:0015		UTIL BREAKER STATUS
0:0016		FUEL TRANSFER (TRUE = LIQ)
0:0017		LOWER VOLTAGE (VAR/PF) CMD
0:0018		RAISE VOLTAGE (VAR/PF) CMD
0:0019		LOWER PROCESS SETPOINT
0:0020		RAISE PROCESS SETPOINT
0:0021		FLAME DETECTOR A
0:0022		FLAME DETECTOR B
0:0023		FLAME DETECTOR C
0:0024		FLAME DETECTOR D
0:0025		Enable Output Forcing Mode
0:0026		Force-Energize Output #01 Relay

0:0027	Force-Energize Output #02 Relay
0:0028	Force-Energize Output #03 Relay
0:0029	Force-Energize Output #04 Relay
0:0030	Force-Energize Output #05 Relay
0:0031	Force-Energize Output #06 Relay
0:0032	Force-Energize Output #07 Relay
0:0033	Force-Energize Output #08 Relay
0:0034	Force-Energize Output #09 Relay
0:0035	Force-Energize Output #10 Relay
0:0036	Force-Energize Output #11 Relay
0:0037	Force-Energize Output #12 Relay
0:0038	Manual Crank/Motor
0:0039	Go to Base Load Setpoint
0:0040	ENABLE CALIBRATE MODE
0:0041	EXIT CALIBRATE MODE
0:0042	FUEL TRANSFER HOLD
0:0043	OPEN GEN BREAKER CMD
0:0044	SELECT PEAK MODE
0:0045	
0:0046	
0:0047	
0:0048	START DATALOG COLLECTING
0:0049	STOP DATALOG COLLECTING
0:0050	
0:0051	Available for
thru	Custom
0:0200	Inputs

## Boolean Reads (RPTbr)

Addr	Input	Description
1:0001	A02_TC.BI_01.BI_ATL	SHUTDOWN (CHOP FUEL)
1:0002	A02_TC.BI_02.BI_ATL	START/RUN
1:0003	A02_TC.BI_03.BI_ATL	SYSTEM RESET (ALM & SD)
1:0004	A02_TC.BI_04.BI_ATL	SYSTEM ACKNOWLEDGE (ALM & SD)
1:0005	A02_TC.BI_05.BI_ATL	PT REFERENCE LOWER
1:0006	A02_TC.BI_06.BI_ATL	PT REFERENCE RAISE
1:0007	A02_TC.BI_07.BI_ATL	PT REFERENCE SELECT FAST RATE
1:0008	A02_TC.BI_08.BI_ATL	PT SPEED SIGNAL FAILED OVERRIDE
1:0009	A02_TC.BI_09.BI_ATL	SET PT REFERENCE TO RATED
1:0010	A02_TC.BI_10.BI_ATL	ENABLE PROCESS CONTROL
1:0011	A02_TC.BI_11.BI_ATL	ENABLE VAR/PF CONTROL
1:0012	A02_TC.BI_12.BI_ATL	ENABLE REMOTE PT REF SETPOINT
1:0013	A02_TC.BI_13.BI_ATL	INHIBIT SYNCHRONIZER
1:0014	A02_TC.BI_14.BI_ATL	GEN BREAKER STATUS (T=CLOSED)
1:0015	A02_TC.BI_15.BI_ATL	UTIL BREAKER STATUS (T=OPEN)
1:0016	A02_TC.BI_16.BI_ATL	FUEL SELECTION / TRANSER
1:0017	A02_TC.BI_17.BI_ATL	LOWER VOLTAGE (VAR/PF) CMD
1:0018	A02_TC.BI_18.BI_ATL	RAISE VOLTAGE (VAR/PF) CMD

1:0019	A02_TC.BI_19.BI_ATL	LOWER PROCESS SETPOINT
1:0020	A02_TC.BI_20.BI_ATL	RAISE PROCESS SETPOINT
1:0021	A02_TC.BI_21.BI_ATL	FLAME DETECTOR A
1:0022	A02_TC.BI_22.BI_ATL	FLAME DETECTOR B
1:0023	A02_TC.BI_23.BI_ATL	FLAME DETECTOR C
1:0024	A02_TC.BI_24.BI_ATL	FLAME DETECTOR D
1:0025	FALSE	
1:0026	A02_PB_MO1.BO_01.DISPLAY	
1:0027	A02_PB_MO1.BO_02.DISPLAY	
1:0028	A02_PB_MO1.BO_03.DISPLAY	
1:0029	A02_PB_MO1.BO_04.DISPLAY	
1:0030	A02_PB_MO1.BO_05.DISPLAY	
1:0031	A02_PB_MO1.BO_06.DISPLAY	
1:0032	A02_PB_MO1.BO_07.DISPLAY	
1:0033	A02_PB_MO1.BO_08.DISPLAY	
1:0034	A02_PB_MO1.BO_09.DISPLAY	
1:0035	A02_PB_MO1.BO_10.DISPLAY	
1:0036	A02_PB_MO1.BO_11.DISPLAY	
1:0037	A02_PB_MO1.BO_12.DISPLAY	
1:0038	A2_PS_OUTB.PTUNITINFO.EQ	
1:0039	A2_PS_OUTB.CTUNITINFO.EQ	
1:0040	A2_PS_OUTG.PWRUNITS.EQ	
1:0041	A2_PS_OUTB.PWRUNITS.EQ	
1:0042	SYNC_SEQ.DISABLED.B_NAME	Synchronizer Disabled
1:0043	SYNC_SEQ.CHECK.B_NAME	Synchronizer in Check Mode
1:0044	SYNC_SEQ.RUN.B_NAME	Synchronizer in Run Mode
1:0045	SYNC_SEQ.PERMISSIV.B_NAME	Synchronizer in Permissive Mode
1:0046		
1:0047		
1:0048		
1:0049		
1:0050		
1:0051	CORE_BVAL.AUX1CTRL.B_NAME	AUX 1 in Control
1:0052	CORE_BVAL.SPDCTRL.B_NAME	Speed in Control
1:0053	CORE_BVAL.EGTCTRL.B_NAME	EGT in Control
1:0054	CORE_BVAL.ACCELCTRL.B_NAME	ACCEL in Control
1:0055	CORE_BVAL.STRTCTRL.B_NAME	Start Ramp in Control
1:0056	CORE_BVAL.AUX2CTRL.B_NAME	AUX 2 in Control
1:0057	CORE_BVAL.MWLIMCTRL.B_NAME	MW Limit in Control
1:0058	CORE_BVAL.EGTDV_CTRL.B_NAME	
1:0059	CORE_BVAL.DECCTRL.B_NAME	
1:0060	CORE_BVAL.FUELOFCTRL.B_NAME	
1:0061	CORE_BVAL.GAS_100.B_NAME	
1:0062	CORE_BVAL.LIQ_100.B_NAME	
1:0063		
1:0064	MP.MP_WATCH.B_NAME	MultiProg is Running
1:0065	CNFG_BI_01.SD_FUEL.OR	
1:0066	CNFG_BI_02.START_RUN.OR	
1:0067	CNFG_BI_03.RESET.OR	
1:0068	CNFG_BI_04.ACKN.OR	

1:0069	CNFG_BI_05.SPD_LOWER.OR	
1:0070	CNFG_BI_06.SPD_RAISE.OR	
1:0071	CNFG_BI_07.PT_FSTRATE.OR	
1:0072	CNFG_BI_08.SPD_OVERRIDE.OR	
1:0073	CNFG_BI_09.PT_RATED.OR	
1:0074	CNFG_BI_10.ENA_PROCES.OR	
1:0075	CNFG_BI_11.ENA_VARPF.OR	
1:0076	CNFG_BI_12.REM_SPDREF.OR	
1:0077	CNFG_BI_13.SYNC_INHIB.OR	
1:0078	CNFG_BI_14.GBRKR_CLOS.OR	
1:0079	CNFG_BI_15.UBRKR_OPEN.OR	
1:0080	CNFG_BI_16.FUEL_XFER.OR	
1:0081	CNFG_BI_17.LWR_VOLTS.OR	
1:0082	CNFG_BI_18.RAZ_VOLTS.OR	
1:0083	CNFG_BI_19.LWR_PROCES.OR	
1:0084	CNFG_BI_20.RAZ_PROCES.OR	
1:0085	CNFG_BI_21.FLAMEDET_A.OR	
1:0086	CNFG_BI_22.FLAMEDET_B.OR	
1:0087	CNFG_BI_23.FLAMEDET_C.OR	
1:0088	CNFG_BI_24.FLAMEDET_D.OR	
1:0089	CALMODE.CAL_PERM.AND	Permissives Met for Calibration Mode
1:0090	CALMODE.CALMODE.B_NAME	Unit in Calibration Mode
1:0091		
1:0092	SEQ.GL_X_HOLD.OR	Hold Fuel Transfer to Fuel Control COR
1:0093	START.START_PERM.AND	Permissives Met to Start Unit
1:0094	SD_SUM.SHUTDOWN.B_NAME	Hard Shutdown Summary
1:0095	SD_SUM.ANY_OPNBRK.OR	Soft Shutdown Summary
1:0096	ALM_SUM.ALARMS.OR	Alarm Summary
1:0097	CORE.ALM_OUT_C.B_NAME	Summary Alarm from CORE
1:0098	CORE.SD_SOFT_C.B_NAME	Summary Soft SD from CORE
1:0099	CORE.SD_HARD_C.B_NAME	Summary Hard SD from CORE
1:0100		** EVENTS LIST STARTS AT 100 **
1:0101	CORE.EVENTS1.EVENT001	Shaft OVERSPEED ALM Level
1:0102	CORE.EVENTS1.EVENT002	Shaft OVERSPEED SD Level
1:0103	CORE.EVENTS1.EVENT003	Speed Signal Difference
1:0104	CORE.EVENTS1.EVENT004	ALL SPEED SENSORS FAILED
1:0105	CORE.EVENTS1.EVENT005	Shaft Overspeed Test Enabled
1:0106	CORE.EVENTS1.EVENT006	CDP HIGH PRESSURE SD
1:0107	CORE.EVENTS1.EVENT007	EGT Signal Low - post OVRD
1:0108	CORE.EVENTS1.EVENT008	EGT OVERTEMP ALM
1:0109	CORE.EVENTS1.EVENT009	EGT OVERTEMP SD
1:0110	CORE.EVENTS1.EVENT010	Excessive EGT T/C Spread ALM
1:0111	CORE.EVENTS1.EVENT011	Excessive EGT T/C Spread SD
1:0112	CORE.EVENTS1.EVENT012	Excessive # of T/C Faults ALM
1:0113	CORE.EVENTS1.EVENT013	Excessive # of T/C Faults SD
1:0114	CORE.EVENTS1.EVENT014	ANALOG EGT SENSOR FAULT
1:0115	CORE.EVENTS1.EVENT015	SINGLE EGT TC FAULT
1:0116	CORE.EVENTS1.EVENT016	EGT T/C 01 DIFFERENCE ALM
1:0117	CORE.EVENTS1.EVENT017	EGT T/C 02 DIFFERENCE ALM
1:0118	CORE.EVENTS1.EVENT018	EGT T/C 03 DIFFERENCE ALM

1:0119	CORE.EVENTS1.EVENT019	EGT T/C 04 DIFFERENCE ALM
1:0120	CORE.EVENTS1.EVENT020	EGT T/C 05 DIFFERENCE ALM
1:0121	CORE.EVENTS1.EVENT021	EGT T/C 06 DIFFERENCE ALM
1:0122	CORE.EVENTS1.EVENT022	EGT T/C 07 DIFFERENCE ALM
1:0123	CORE.EVENTS1.EVENT023	EGT T/C 08 DIFFERENCE ALM
1:0124	CORE.EVENTS1.EVENT024	EGT T/C 09 DIFFERENCE ALM
1:0125	CORE.EVENTS1.EVENT025	EGT T/C 10 DIFFERENCE ALM
1:0126	CORE.EVENTS1.EVENT026	EGT T/C 11 DIFFERENCE ALM
1:0127	CORE.EVENTS1.EVENT027	EGT T/C 12 DIFFERENCE ALM
1:0128	CORE.EVENTS1.EVENT028	EGT T/C 13 DIFFERENCE ALM
1:0129	CORE.EVENTS1.EVENT029	EGT T/C 14 DIFFERENCE ALM
1:0130	CORE.EVENTS1.EVENT030	EGT T/C 15 DIFFERENCE ALM
1:0131	CORE.EVENTS1.EVENT031	EGT T/C 16 DIFFERENCE ALM
1:0132	CORE.EVENTS1.EVENT032	EGT T/C 17 DIFFERENCE ALM
1:0133	CORE.EVENTS1.EVENT033	EGT T/C 18 DIFFERENCE ALM
1:0134	CORE.EVENTS1.EVENT034	Failure of 3 Adjacent T/C's
1:0135	CORE.EVENTS1.EVENT035	Discrete Input Flame Detector FLT
1:0136	CORE.EVENTS1.EVENT036	Analog Input Flame Detector FLT
1:0137	CORE.EVENTS1.EVENT037	External Contact SD input
1:0138	CORE.EVENTS1.EVENT038	All CDP Sensors Failed
1:0139	CORE.EVENTS1.EVENT039	Starter Engaged - No Speed Detected
1:0140	CORE.EVENTS1.EVENT040	Turbine Failed to Lite-Off
1:0141	CORE.EVENTS1.EVENT041	Loss of Flame in Combustor
1:0142	CORE.EVENTS1.EVENT042	Unit Failed to Reach Idle Speed
1:0143	CORE.EVENTS1.EVENT043	Unit Failed to Reach Rated Speed
1:0144	CORE.EVENTS1.EVENT044	
1:0145	CORE.EVENTS1.EVENT045	
1:0146	CORE.EVENTS1.EVENT046	
1:0147	CORE.EVENTS1.EVENT047	
1:0148	CORE.EVENTS1.EVENT048	
1:0149	CORE.EVENTS1.EVENT049	
1:0150	CORE.EVENTS1.EVENT050	
1:0151	CORE.EVENTS1.EVENT051	
1:0152	CORE.EVENTS1.EVENT052	
1:0153	CORE.EVENTS1.EVENT053	
1:0154	CORE.EVENTS1.EVENT054	
1:0155	CORE.EVENTS1.EVENT055	
1:0156	CORE.EVENTS1.EVENT056	
1:0157	CORE.EVENTS1.EVENT057	
1:0158	CORE.EVENTS1.EVENT058	
1:0159	CORE.EVENTS1.EVENT059	
1:0160	CORE.EVENTS1.EVENT060	
1:0161	CORE.EVENTS1.EVENT061	
1:0162	CORE.EVENTS1.EVENT062	
1:0163	CORE.EVENTS1.EVENT063	
1:0164	CORE.EVENTS1.EVENT064	
1:0165	CORE.EVENTS1.EVENT065	
1:0166	CORE.EVENTS1.EVENT066	
1:0167	CORE.EVENTS1.EVENT067	
1:0168	CORE.EVENTS1.EVENT068	

1:0169 CORE.EVENTS1.EVENT069  
1:0170 CORE.EVENTS1.EVENT070  
1:0171 CORE.EVENTS1.EVENT071  
1:0172 CORE.EVENTS1.EVENT072  
1:0173 CORE.EVENTS1.EVENT073  
1:0174 CORE.EVENTS1.EVENT074  
1:0175 CORE.EVENTS1.EVENT075  
1:0176 CORE.EVENTS2.EVENT076  
1:0177 CORE.EVENTS2.EVENT077  
1:0178 CORE.EVENTS2.EVENT078  
1:0179 CORE.EVENTS2.EVENT079  
1:0180 CORE.EVENTS2.EVENT080  
1:0181 CORE.EVENTS2.EVENT081  
1:0182 CORE.EVENTS2.EVENT082  
1:0183 CORE.EVENTS2.EVENT083  
1:0184 CORE.EVENTS2.EVENT084  
1:0185 CORE.EVENTS2.EVENT085  
1:0186 CORE.EVENTS2.EVENT086  
1:0187 CORE.EVENTS2.EVENT087  
1:0188 CORE.EVENTS2.EVENT088  
1:0189 CORE.EVENTS2.EVENT089  
1:0190 CORE.EVENTS2.EVENT090  
1:0191 CORE.EVENTS2.EVENT091  
1:0192 CORE.EVENTS2.EVENT092  
1:0193 CORE.EVENTS2.EVENT093  
1:0194 CORE.EVENTS2.EVENT094  
1:0195 CORE.EVENTS2.EVENT095  
1:0196 CORE.EVENTS2.EVENT096  
1:0197 CORE.EVENTS2.EVENT097  
1:0198 CORE.EVENTS2.EVENT098  
1:0199 CORE.EVENTS2.EVENT099  
1:0200 CORE.EVENTS2.EVENT100  
1:0201 ALARM.EVENT101.B\_ALARM  
1:0202 ALARM.EVENT102.B\_ALARM  
1:0203 ALARM.EVENT103.B\_ALARM  
1:0204 ALARM.EVENT104.B\_ALARM  
1:0205 ALARM.EVENT105.B\_ALARM  
1:0206 ALARM.EVENT106.B\_ALARM  
1:0207 ALARM.EVENT107.B\_ALARM  
1:0208 ALARM.EVENT108.B\_ALARM  
1:0209 ALARM.EVENT109.B\_ALARM  
1:0210 ALARM.EVENT110.B\_ALARM  
1:0211 ALARM.EVENT111.B\_ALARM  
1:0212 ALARM.EVENT112.B\_ALARM  
1:0213 ALARM.EVENT113.B\_ALARM  
1:0214 ALARM.EVENT114.B\_ALARM  
1:0215 ALARM.EVENT115.B\_ALARM  
1:0216 FALSE  
1:0217 FALSE  
1:0218 FALSE

Shutdown came from Master GAP  
Begins Master Events List

1:0219 CNFG\_BI\_04.EVENT119.B\_ALARM  
1:0220 CNFG\_BI\_05.EVENT120.B\_ALARM  
1:0221 CNFG\_BI\_06.EVENT121.B\_ALARM  
1:0222 CNFG\_BI\_07.EVENT122.B\_ALARM  
1:0223 CNFG\_BI\_08.EVENT123.B\_ALARM  
1:0224 CNFG\_BI\_09.EVENT124.B\_ALARM  
1:0225 CNFG\_BI\_10.EVENT125.B\_ALARM  
1:0226 CNFG\_BI\_11.EVENT126.B\_ALARM  
1:0227 CNFG\_BI\_12.EVENT127.B\_ALARM  
1:0228 CNFG\_BI\_13.EVENT128.B\_ALARM  
1:0229 CNFG\_BI\_14.EVENT129.B\_ALARM  
1:0230 CNFG\_BI\_15.EVENT130.B\_ALARM  
1:0231 CNFG\_BI\_16.EVENT131.B\_ALARM  
1:0232 CNFG\_BI\_17.EVENT132.B\_ALARM  
1:0233 CNFG\_BI\_18.EVENT133.B\_ALARM  
1:0234 CNFG\_BI\_19.EVENT134.B\_ALARM  
1:0235 CNFG\_BI\_20.EVENT135.B\_ALARM  
1:0236 CNFG\_BI\_21.EVENT136.B\_ALARM  
1:0237 CNFG\_BI\_22.EVENT137.B\_ALARM  
1:0238 CNFG\_BI\_23.EVENT138.B\_ALARM  
1:0239 CNFG\_BI\_24.EVENT139.B\_ALARM  
1:0240 ALARM.EVENT140.B\_ALARM  
1:0241 ALARM.EVENT141.B\_ALARM  
1:0242 ALARM.EVENT142.B\_ALARM  
1:0243 ALARM.EVENT143.B\_ALARM  
1:0244 ALARM.EVENT144.B\_ALARM  
1:0245 ALARM.EVENT145.B\_ALARM  
1:0246 ALARM.EVENT146.B\_ALARM  
1:0247 ALARM.EVENT147.B\_ALARM  
1:0248 ALARM.EVENT148.B\_ALARM  
1:0249 ALARM.EVENT149.B\_ALARM  
1:0250 ALARM.EVENT150.B\_ALARM  
1:0251 ALARM.EVENT151.B\_ALARM  
1:0252 ALARM.EVENT152.B\_ALARM  
1:0253 ALARM.EVENT153.B\_ALARM  
1:0254 ALARM.EVENT154.B\_ALARM  
1:0255 ALARM.EVENT155.B\_ALARM  
1:0256 ALARM.EVENT156.B\_ALARM  
1:0257 ALARM.EVENT157.B\_ALARM  
1:0258 ALARM.EVENT158.B\_ALARM  
1:0259 ALARM.EVENT159.B\_ALARM  
1:0260 ALARM.EVENT160.B\_ALARM  
1:0261 ALARM.EVENT161.B\_ALARM  
1:0262 ALARM.EVENT162.B\_ALARM  
1:0263 ALARM.EVENT163.B\_ALARM  
1:0264 ALARM.EVENT164.B\_ALARM  
1:0265 ALARM.EVENT165.B\_ALARM  
1:0266 ALARM.EVENT166.B\_ALARM  
1:0267 ALARM.EVENT167.B\_ALARM  
1:0268 ALARM.EVENT168.B\_ALARM



1:0269 ALARM.EVENT169.B\_ALARM  
1:0270 ALARM.EVENT170.B\_ALARM  
1:0271 ALARM.EVENT171.B\_ALARM  
1:0272 ALARM.EVENT172.B\_ALARM  
1:0273 ALARM.EVENT173.B\_ALARM  
1:0274 ALARM.EVENT174.B\_ALARM  
1:0275 ALARM.EVENT175.B\_ALARM  
1:0276 ALARM.EVENT176.B\_ALARM  
1:0277 ALARM.EVENT177.B\_ALARM  
1:0278 ALARM.EVENT178.B\_ALARM  
1:0279 ALARM.EVENT179.B\_ALARM  
1:0280 ALARM.EVENT180.B\_ALARM  
1:0281 ALARM.EVENT181.B\_ALARM  
1:0282 ALARM.EVENT182.B\_ALARM  
1:0283 ALARM.EVENT183.B\_ALARM  
1:0284 ALARM.EVENT184.B\_ALARM  
1:0285 ALARM.EVENT185.B\_ALARM  
1:0286 ALARM.EVENT186.B\_ALARM  
1:0287 ALARM.EVENT187.B\_ALARM  
1:0288 ALARM.EVENT188.B\_ALARM  
1:0289 ALARM.EVENT189.B\_ALARM  
1:0290 ALARM.EVENT190.B\_ALARM  
1:0291 ALARM.EVENT191.B\_ALARM  
1:0292 ALARM.EVENT192.B\_ALARM  
1:0293 ALARM.EVENT193.B\_ALARM  
1:0294 ALARM.EVENT194.B\_ALARM  
1:0295 ALARM.EVENT195.B\_ALARM  
1:0296 ALARM.EVENT196.B\_ALARM  
1:0297 ALARM.EVENT197.B\_ALARM  
1:0298 ALARM.EVENT198.B\_ALARM  
1:0299 ALARM.EVENT199.B\_ALARM  
1:0300 ALARM.EVENT200.B\_ALARM  
1:0301 ALARM.EVENT201.B\_ALARM  
1:0302 ALARM.EVENT202.B\_ALARM  
1:0303 ALARM.EVENT203.B\_ALARM  
1:0304 ALARM.EVENT204.B\_ALARM  
1:0305 ALARM.EVENT205.B\_ALARM  
1:0306 ALARM.EVENT206.B\_ALARM  
1:0307 ALARM.EVENT207.B\_ALARM  
1:0308 ALARM.EVENT208.B\_ALARM  
1:0309 ALARM.EVENT209.B\_ALARM  
1:0310 ALARM.EVENT210.B\_ALARM  
1:0311 ALARM.EVENT211.B\_ALARM  
1:0312 ALARM.EVENT212.B\_ALARM  
1:0313 ALARM.EVENT213.B\_ALARM  
1:0314 ALARM.EVENT214.B\_ALARM  
1:0315 ALARM.EVENT215.B\_ALARM  
1:0316 ALARM.EVENT216.B\_ALARM  
1:0317 ALARM.EVENT217.B\_ALARM  
1:0318 ALARM.EVENT218.B\_ALARM

1:0319 ALARM.EVENT219.B\_ALARM  
1:0320 ALARM.EVENT220.B\_ALARM  
1:0321 ALARM.EVENT221.B\_ALARM  
1:0322 ALARM.EVENT222.B\_ALARM  
1:0323 ALARM.EVENT223.B\_ALARM  
1:0324 ALARM.EVENT224.B\_ALARM  
1:0325 ALARM.EVENT225.B\_ALARM  
1:0326 ALARM.EVENT226.B\_ALARM  
1:0327 ALARM.EVENT227.B\_ALARM  
1:0328 ALARM.EVENT228.B\_ALARM  
1:0329 ALARM.EVENT229.B\_ALARM  
1:0330 ALARM.EVENT230.B\_ALARM  
1:0331 ALARM.EVENT231.B\_ALARM  
1:0332 ALARM.EVENT232.B\_ALARM  
1:0333 ALARM.EVENT233.B\_ALARM  
1:0334 ALARM.EVENT234.B\_ALARM  
1:0335 ALARM.EVENT235.B\_ALARM  
1:0336 ALARM.EVENT236.B\_ALARM  
1:0337 ALARM.EVENT237.B\_ALARM  
1:0338 ALARM.EVENT238.B\_ALARM  
1:0339 ALARM.EVENT239.B\_ALARM  
1:0340 ALARM.EVENT240.B\_ALARM  
1:0341 ALARM.EVENT241.B\_ALARM  
1:0342 ALARM.EVENT242.B\_ALARM  
1:0343 ALARM.EVENT243.B\_ALARM  
1:0344 ALARM.EVENT244.B\_ALARM  
1:0345 ALARM.EVENT245.B\_ALARM  
1:0346 ALARM.EVENT246.B\_ALARM  
1:0347 ALARM.EVENT247.B\_ALARM  
1:0348 ALARM.EVENT248.B\_ALARM  
1:0349 ALARM.EVENT249.B\_ALARM  
1:0350 ALARM.EVENT250.B\_ALARM  
1:0351 CNFG\_AI01.EVENT251.B\_ALARM  
1:0352 CNFG\_AI02.EVENT252.B\_ALARM  
1:0353 CNFG\_AI03.EVENT253.B\_ALARM  
1:0354 CNFG\_AI04.EVENT254.B\_ALARM  
1:0355 CNFG\_AI05.EVENT255.B\_ALARM  
1:0356 CNFG\_AI06.EVENT256.B\_ALARM  
1:0357 CNFG\_AI07.EVENT257.B\_ALARM  
1:0358 CNFG\_AI08.EVENT258.B\_ALARM  
1:0359 CNFG\_AI09.EVENT259.B\_ALARM  
1:0360 CNFG\_AI10.EVENT260.B\_ALARM  
1:0361 CNFG\_AI11.EVENT261.B\_ALARM  
1:0362 CNFG\_AI12.EVENT262.B\_ALARM  
1:0363 CNFG\_AI13.EVENT263.B\_ALARM  
1:0364 CNFG\_AI14.EVENT264.B\_ALARM  
1:0365 CNFG\_AI15.EVENT265.B\_ALARM  
1:0366 CNFG\_AI16.EVENT266.B\_ALARM  
1:0367  
1:0368

1:0369  
1:0370  
1:0371  
1:0372  
1:0373  
1:0374  
1:0375  
1:0376  
1:0377  
1:0378  
1:0379  
1:0380  
1:0381  
1:0382  
1:0383  
1:0384  
1:0385  
1:0386  
1:0387  
1:0388  
1:0389  
1:0390  
1:0391  
1:0392  
1:0393  
1:0394  
1:0395  
1:0396  
1:0397  
1:0398  
1:0399  
1:0400  
1:0401 ALM\_SUM.ALM\_MP.SEL\_1  
1:0402 ALM\_SUM.ALM\_MP.SEL\_2  
1:0403 ALM\_SUM.ALM\_MP.SEL\_3  
thru  
1:0799 ALM\_SUM.ALM\_MP.SEL\_399  
1:0800 ALM\_SUM.ALM\_MP.SEL\_400  
1:0801 SD\_SUM.SD\_MP.SEL\_1  
1:0802 SD\_SUM.SD\_MP.SEL\_2  
1:0803 SD\_SUM.SD\_MP.SEL\_3  
thru  
1:0899 SD\_SUM.SD\_MP.SEL\_99  
1:0900 SD\_SUM.SD\_MP.SEL\_100  
1:0901 SD\_SUM.OPBRKR\_MP.SEL\_1  
1:0902 SD\_SUM.OPBRKR\_MP.SEL\_2  
1:0903 SD\_SUM.OPBRKR\_MP.SEL\_3  
thru  
1:0949 SD\_SUM.OPBRKR\_MP.SEL\_49  
1:0950 SD\_SUM.OPBRKR\_MP.SEL\_50

\*\*\* MP Modbus Signals Start at 400\*\*\*

1:0951 \*FALSE  
 thru  
 1:1400 \*FALSE

These 450 inputs are available for  
 Multiprog to write into directly

## Analog Reads (RPTar)

Addr	Input	Description	Multip lier
3:0001	CORE_AVAL.ACCEL_OUT.A_NAME	ACCEL CONTROL	
3:0002	CORE_AVAL.DECCEL_OUT.A_NAME	DECEL CONTROL	
3:0003	CORE_AVAL.START_CTRL.A_NAME	START RAMP CONTROL	
3:0004	DISPLAY.CDPHSS.A_SW	CDP HIGH SIGNAL SELECT	
3:0005	CORE_AVAL.GAS_DMD.A_NAME	GAS VALVE DEMAND	
3:0006	CORE_AVAL.LIQ_DMD.A_NAME	LIQUID VALVE DEMAND	
3:0007	CORE_AVAL.VLV_DMND.A_NAME	VALVE DEMAND	
3:0008	DISPLAY.EGT_AVG.A_SW	EGT AVERAGE	
3:0009	CORE_AVAL.EGT_PID.A_NAME	EGT CONTROL	
3:0010	DISPLAY.EGT_SPRD.A_SW	EGT SPREAD	
3:0011	CORE_AVAL.EGTDRV_PID.A_NAME	EGT DERIVATIVE PID	
3:0012	MP.AUX1_PID.PID_2	Aux 1 PID (from MP)	
3:0013	MP.AUX2_PID.PID_2	Aux 2 PID (from MP)	
3:0014	MP.AUX3_PID.PID_2	Aux 3 PID (from MP)	
3:0015	CORE_AVAL.ACCEL_PID.A_NAME	ACCEL SPEED DERIV PID CONTROL	
3:0016	CORE_AVAL.MW_LIM.A_NAME	MAX MW CONTROL LIMIT	
3:0017	CORE_AVAL.V_REFERNC.A_NAME	Voltage Reference Setpoint	
3:0018	SYNC_SEQ.MODE_AVAL.OUT_1	Synchronizer Mode	
3:0019			
3:0020			
3:0021	DISPLAY.SPD_MONITR.HSS_BUS	Display (Monitor) Speed	
3:0022	CORE_AVAL.SPD_HSS.A_NAME	SPEED HIGH SIGNAL SELECT	
3:0023	CORE_AVAL.SPD_PID.A_NAME	SPEED CONTROL	
3:0024	CORE_AVAL.SPD_REF.A_NAME	SPEED REFERENCE	
3:0025	CORE_AVAL.MPSPDREF.A_NAME	MP SPEED REFERENCE	
3:0026			
3:0027	ALM_SUM.FIRST_OUT.A_MUX_N_1	First Alarm to set Latch (#)	
3:0028	SD_SUM.FIRSTOUTOB.A_MUX_N_1	First SOFT SD to set Latch (#)	
3:0029	SD_SUM.FIRST_OUT.A_MUX_N_1	First HARD SD to set Latch (#)	
3:0030	DISPLAY.EGT_REF.A_SW	EGT REFERENCE	
3:0031	CORE_AVAL.LSS_BUS.A_NAME	Fuel Demand LSS Bus 1	
3:0032	CORE_AVAL.HSS.A_NAME	Fuel Demand HSS Bus	
3:0033	CORE_AVAL.LSS_2.A_NAME	Fuel Demand LSS Bus 2	
3:0034	DISPLAY.AMBTEMPANY.A_SW	Ambient Inlet Temp (Any type)	
3:0035	A2_PS_OUTG.GEN_MWATTS.A_NAME	Turbine MW Load (Snsr or Calc)	
3:0036	A2_PS_OUTG.GEN_KVAR.A_NAME	Turbine Gen MVAR output	
3:0037	A2_PS_OUTG.GEN_KVA.A_NAME	Turbine Gen MVA output	
3:0038	CORE_AVAL.FUEL_DCURV.A_NAME	Fuel Decel Limit Curve (vs CDP)	
3:0039	CORE_AVAL.FUEL_ACURV.A_NAME	Fuel Accel Limit Curve (vs CDP)	
3:0040	NV_MEM.LOG.OUT_1	Turbine Number of Fired Starts	
3:0041	NV_MEM.LOG.OUT_2	Turbine Start Attempts	
3:0042	NV_MEM.LOG.OUT_3	Turbine CORE Shutdowns (accumulated)	
3:0043	NV_MEM.LOG.OUT_4	Turbine Run Hours (accumulated)	

3:0044	NV_MEM.LOG.OUT_5	
3:0045	NV_MEM.LOG.OUT_6	
3:0046	NV_MEM.LOG.OUT_7	
3:0047	NV_MEM.LOG.OUT_8	
3:0048	NV_MEM.LOG.OUT_9	
3:0049	NV_MEM.LOG.OUT_10	
3:0050	NV_MEM.LOG.OUT_11	
3:0051	NV_MEM.LOG.OUT_12	
3:0052	NV_MEM.LOG.OUT_13	
3:0053	NV_MEM.LOG.OUT_14	
3:0054	NV_MEM.LOG.OUT_15	
3:0055	NV_MEM.LOG.OUT_16	
3:0056	NV_MEM.LOG.OUT_17	
3:0057	NV_MEM.LOG.OUT_18	
3:0058	NV_MEM.LOG.OUT_19	
3:0059	NV_MEM.LOG.OUT_20	
3:0060		
thru		
3:0098		
3:0099		
3:0100		*** Atlas H/W Analog Signals ***
3:0101	A02_TC.DSS_01.TSS_ATL	SPEED PROBE A
3:0102	A02_TC.DSS_02.TSS_ATL	SPEED PROBE B
3:0103	A02_TC.AI_01.AI_ATL	PROCESS CONTROL INPUT
3:0104	A02_TC.AI_02.AI_ATL	REMOTE SPEED REF SETTING
3:0105	A02_TC.AI_03.AI_ATL	REM PROCESS CONTROL SETPOINT
3:0106	A02_TC.AI_04.AI_ATL	AMBIENT TURB INLET TEMP (4-20mA)
3:0107	A02_TC.AI_05.AI_ATL	REM VAR/PF REFERENCE
3:0108	A02_TC.AI_06.AI_ATL	EGT TEMP SUMMARY (if 4-20mA used)
3:0109	A02_TC.AO_01.DISPLAY	AO #1 READOUT
3:0110	A02_TC.AO_02.DISPLAY	AO #2 READOUT
3:0111	A02_TC.AO_03.DISPLAY	AO #3 READOUT
3:0112	A02_TC.AO_04.DISPLAY	AO #4 READOUT
3:0113	A02_TC.AO_05.DISPLAY	AO #5 READOUT
3:0114	A02_TC.AO_06.DISPLAY	AO #6 READOUT
3:0115	A02_TC.ACT_01.ACT_ATL	GAS FUEL VALVE DMD (ACT #1)
3:0116	A02_TC.ACT_02.ACT_ATL	LIQUID FUEL VALVE DMD (ACT #2)
3:0117	A04_COMBO.DSS_03.TSS_ATL	SPEED PROBE C
3:0118	A04_COMBO.DSS_04.TSS_ATL	SPEED PROBE D
3:0119	DISPLAY.TC01.A_SW	EGT T/C #1
3:0120	DISPLAY.TC02.A_SW	EGT T/C #2
3:0121	DISPLAY.TC03.A_SW	EGT T/C #3
3:0122	DISPLAY.TC04.A_SW	EGT T/C #4
3:0123	DISPLAY.TC05.A_SW	EGT T/C #5
3:0124	DISPLAY.TC06.A_SW	EGT T/C #6
3:0125	DISPLAY.TC07.A_SW	EGT T/C #7
3:0126	DISPLAY.TC08.A_SW	EGT T/C #8
3:0127	DISPLAY.TC09.A_SW	EGT T/C #9
3:0128	DISPLAY.TC10.A_SW	EGT T/C #10
3:0129	A04_COMBO.AI_07.AI_420_ATL	CDP SENSOR A (4-20 mA)

3:0130	A04_COMBO.AI_08.AI_420_ATL	REM MW REF SETPOINT
3:0131	A04_COMBO.AI_09.AI_420_ATL	P1 GAS INLET PRESSURE
3:0132	A04_COMBO.AI_10.AI_420_ATL	P2 GAS PRESSURE A
3:0133	A04_COMBO.AI_11.AI_420_ATL	P2 GAS PRESSURE B
3:0134	DISPLAY.CJ01.A_SW	T/C COLD JUNCTION SENSOR
3:0135	A04_COMBO.AO_07.DISPLAY	AO #7 READOUT
3:0136	A04_COMBO.AO_08.DISPLAY	AO #8 READOUT
3:0137	A05_COMBO.DSS_05.TSS_ATL	CUSTOMER FREQUENCY A
3:0138	A05_COMBO.DSS_06.TSS_ATL	CUSTOMER FREQUENCY B
3:0139	DISPLAY.TC11.A_SW	EGT T/C #11
3:0140	DISPLAY.TC12.A_SW	EGT T/C #12
3:0141	DISPLAY.TC13.A_SW	EGT T/C #13
3:0142	DISPLAY.TC14.A_SW	EGT T/C #14
3:0143	DISPLAY.TC15.A_SW	EGT T/C #15
3:0144	DISPLAY.TC16.A_SW	EGT T/C #16
3:0145	DISPLAY.TC17.A_SW	EGT T/C #17
3:0146	DISPLAY.TC18.A_SW	EGT T/C #18
3:0147	DISPLAY.TC19.A_SW	EGT T/C #19
3:0148	DISPLAY.TC20.A_SW	EGT T/C #20
3:0149	A05_COMBO.AI_12.AI_420_ATL	CDP SENSOR B (4-20 mA)
3:0150	A05_COMBO.AI_13.AI_420_ATL	FLAME DETECTOR A INPUT
3:0151	A05_COMBO.AI_14.AI_420_ATL	FLAME DETECTOR B INPUT
3:0152	A05_COMBO.AI_15.AI_420_ATL	FLAME DETECTOR C INPUT
3:0153	A05_COMBO.AI_16.AI_420_ATL	FLAME DETECTOR D INPUT
3:0154	DISPLAY.CJ02.A_SW	T/C COLD JUNCTION SENSOR
3:0155	A05_COMBO.AO_09.DISPLAY	AO #9 READOUT
3:0156	A05_COMBO.AO_10.DISPLAY	AO #10 READOUT
3:0157	A03_PSENSE.SPDBIAS_RO.A_SW	Speed Bias Output
3:0158	A03_PSENSE.VOLTBIASRO.A_SW	Voltage Bias Output
3:0159	A2_PS_OUTG.PT_A_GEN.A_NAME	
3:0160	A2_PS_OUTG.PT_B_GEN.A_NAME	
3:0161	A2_PS_OUTG.PT_C_GEN.A_NAME	
3:0162	A2_PS_OUTG.PT_GEN_AVG.A_NAME	
3:0163	A2_PS_OUTG.CT_A_GEN.A_NAME	
3:0164	A2_PS_OUTG.CT_B_GEN.A_NAME	
3:0165	A2_PS_OUTG.CT_C_GEN.A_NAME	
3:0166	A2_PS_OUTG.CT_GEN_AVG.A_NAME	
3:0167	A2_PS_OUTG.GEN_PWR_A.A_NAME	
3:0168	A2_PS_OUTG.GEN_PWR_B.A_NAME	
3:0169	A2_PS_OUTG.GEN_PWR_C.A_NAME	
3:0170	A2_PS_OUTG.GEN_MWATTS.A_NAME	
3:0171	A2_PS_OUTG.GEN_VA_A.A_NAME	
3:0172	A2_PS_OUTG.GEN_VA_B.A_NAME	
3:0173	A2_PS_OUTG.GEN_VA_C.A_NAME	
3:0174	A2_PS_OUTG.GEN_KVA.A_NAME	
3:0175	A2_PS_OUTG.GEN_VAR_A.A_NAME	
3:0176	A2_PS_OUTG.GEN_VAR_B.A_NAME	
3:0177	A2_PS_OUTG.GEN_VAR_C.A_NAME	
3:0178	A2_PS_OUTG.GEN_KVAR.A_NAME	
3:0179	A2_PS_OUTG.GEN_NPHV.A_NAME	

3:0180 A2\_PS\_OUTG.GEN\_NPHA.A\_NAME  
3:0181 A2\_PS\_OUTB.PT\_A\_BUS.A\_NAME  
3:0182 A2\_PS\_OUTB.PT\_B\_BUS.A\_NAME  
3:0183 A2\_PS\_OUTB.PT\_C\_BUS.A\_NAME  
3:0184 A2\_PS\_OUTB.PT\_BUS\_AVG.A\_NAME  
3:0185 A2\_PS\_OUTB.CT\_A\_BUS.A\_NAME  
3:0186 A2\_PS\_OUTB.CT\_B\_BUS.A\_NAME  
3:0187 A2\_PS\_OUTB.CT\_C\_BUS.A\_NAME  
3:0188 A2\_PS\_OUTB.CT\_BUS\_AVG.A\_NAME  
3:0189 A2\_PS\_OUTB.BUS\_PWR\_A.A\_NAME  
3:0190 A2\_PS\_OUTB.BUS\_PWR\_B.A\_NAME  
3:0191 A2\_PS\_OUTB.BUS\_PWR\_C.A\_NAME  
3:0192 A2\_PS\_OUTB.BUS\_WATTS.A\_NAME  
3:0193 A2\_PS\_OUTB.BUS\_VA\_A.A\_NAME  
3:0194 A2\_PS\_OUTB.BUS\_VA\_B.A\_NAME  
3:0195 A2\_PS\_OUTB.BUS\_VA\_C.A\_NAME  
3:0196 A2\_PS\_OUTB.BUS\_VA.A\_NAME  
3:0197 A2\_PS\_OUTB.BUS\_VAR\_A.A\_NAME  
3:0198 A2\_PS\_OUTB.BUS\_VAR\_B.A\_NAME  
3:0199 A2\_PS\_OUTB.BUS\_VAR\_C.A\_NAME  
3:0200 A2\_PS\_OUTB.BUS\_VAR.A\_NAME Bus Total VAR  
3:0201 A2\_PS\_OUTB.BUS\_NPHV.A\_NAME  
3:0202 A2\_PS\_OUTB.BUS\_NPHA.A\_NAME  
3:0203  
3:0204  
3:0205  
3:0206  
3:0207  
3:0208  
3:0209  
3:0210  
3:0211  
3:0212  
3:0213  
3:0214  
3:0215  
3:0216  
3:0217  
3:0218  
3:0219  
3:0220  
3:0221  
3:0222  
3:0223  
3:0224  
3:0225  
3:0226  
3:0227  
3:0228  
3:0229

3:0230  
 3:0231  
 3:0232  
 3:0233  
 3:0234  
 3:0235  
 3:0236  
 3:0237  
 3:0238  
 3:0239  
 3:0240  
 3:0241  
 3:0242  
 3:0243  
 3:0244  
 3:0245  
 3:0246  
 3:0247  
 3:0248  
 3:0249 \* Start MP accessible inputs at 250 \*  
 3:0250 \*0.0 (-32000.0, 32000.0) The first 75 have a multiplier value  
 3:0251 \*0.0 (-32000.0, 32000.0) available as a tunable  
 3:0252 \*0.0 (-32000.0, 32000.0) from \*1.0 (0.01, 100.0)  
 thru  
 3:0499 \*0.0 (-32000.0, 32000.0)  
 3:0500 \*0.0 (-32000.0, 32000.0)

## Analog Writes (RPTaw)

Addr	Description	Multi- plier
4:0001	Analog Out #1 Force	
4:0002	Analog Out #2 Force	
4:0003	Analog Out #3 Force	
4:0004	Analog Out #4 Force	
4:0005	Analog Out #5 Force	
4:0006	Analog Out #6 Force	
4:0007	Analog Out #7 Force	
4:0008	Analog Out #8 Force	
4:0009	Analog Out #9 Force	
4:0010	Analog Out #10 Force	
4:0011	Actuator Out #1 Force	
4:0012	Actuator Out #2 Force	
4:0013	Fuel Valve Manual Stroke	
4:0014	Customer Dmd1 to AO Mux	
4:0015	Customer Dmd2 to AO Mux	
4:0016	Customer Dmd3 to AO Mux	
4:0017	Customer Dmd4 to AO Mux	
4:0018		
4:0019	*** Multi-Prog Commands ***	
4:0020		



thru  
4:0049  
4:0050

## Appendix C.

# Alarm/Shutdown Event List

When an event occurs, the application sets a numbered Alarm flag (latch) as per the list below. The action to be taken is determined by the configuration option that the user selects for each event. The Quick Service inspector file has a user tunable value for the configuration number as per the chart below. The programmed default actions for these events are shown in the list below. The ACKNOWLEDGE input will turn off the Horn output. The RESET will clear the event latch, if the event condition no longer exists. Event options are as follows:

Configuration Number	Description
1	Disabled (No action taken)
2	Alarm (Audible & Visual annunciation of event)
3	Soft Shutdown (same as Alarm w/ Open Gen Breaker Command)
4	Hard Shutdown (same as Soft w/ Fuel Shut-off)
5	Reserved (MultiProg defined sequence)

### IMPORTANT

Some events are programmed as Hard Shutdowns and are not tunable, such as All Speed Sensors Failed, PT Overspeed, EGT Overtemp, and the Fuel Driver Faults.

#### EVENTS INITIATED IN THE CORE FUEL CONTROL GAP (5418-2358)

Event #	DESCRIPTION	DEFAULT	Site Option
AL_001	Shaft Overspeed ALM level	ALARM	
AL_002	Shaft Overspeed SD level	HARD SHUTDOWN	
AL_003	Speed Signal Difference	ALARM	
AL_004	All Shaft Speed Sig Failed	HARD SHUTDOWN	
AL_005	Shaft Overspeed Test Enabled	ALARM	
AL_006	CDP Over High Press Level	Disabled	
AL_007	EGT Signal Low after OVRD	ALARM	
AL_008	EGT Overtemp ALM level	ALARM	
AL_009	EGT Overtemp SD Level	HARD SHUTDOWN	
AL_010	Excessive EGT Spread Alarm	ALARM	
AL_011	Excessive EGT Spread Shutdown	SOFT SHUTDOWN	
AL_012	Excessive # of T/C Failed ALM	ALARM	
AL_013	Excessive # of T/C Failed SD	HARD SHUTDOWN	
AL_014	EGT Signal via Analog Input Failed	Disabled	
AL_015	Single T/C Input for EGT Failed	HARD SHUTDOWN	
AL_016	T/C 01 Difference ALM	ALARM	
AL_017	T/C 02 Difference ALM	ALARM	
AL_018	T/C 03 Difference ALM	ALARM	
AL_019	T/C 04 Difference ALM	ALARM	
AL_020	T/C 05 Difference ALM	ALARM	
AL_021	T/C 06 Difference ALM	ALARM	
AL_022	T/C 07 Difference ALM	ALARM	
AL_023	T/C 08 Difference ALM	ALARM	
AL_024	T/C 09 Difference ALM	ALARM	

AL_025	T/C 10 Difference ALM	ALARM	
AL_026	T/C 11 Difference ALM	ALARM	
AL_027	T/C 12 Difference ALM	ALARM	
AL_028	T/C 13 Difference ALM	Disabled	
AL_029	T/C 14 Difference ALM	Disabled	
AL_030	T/C 15 Difference ALM	Disabled	
AL_031	T/C 16 Difference ALM	Disabled	
AL_032	T/C 17 Difference ALM	Disabled	
AL_033	T/C 18 Difference ALM	Disabled	
AL_034	Failure of 3 Adjacent T/C signals	Disabled	
AL_035	Discrete Input Flame Detector Failed	Disabled	
AL_036	Analog Input Flame Detector Failed	Disabled	
AL_037	External (DI) Shutdown input	Disabled	
AL_038	All CDP Sensors Failed	Disabled	
AL_039	Starter Engaged - No Speed Detected	ALARM	
AL_040	Turbine Failed to Lite-Off	HARD SHUTDOWN	
AL_041	Loss of Flame in Combustor	HARD SHUTDOWN	
AL_042	Unit Failed to Reach Idle Speed	Disabled	
AL_043	Unit Failed to Reach Rated Speed	Disabled	
AL_044		Disabled	
AL_045		Disabled	
AL_046		Disabled	
AL_047		Disabled	
AL_048		Disabled	
AL_049		Disabled	
AL_050	Gen Breaker Fdbck Failed	SOFT SHUTDOWN	
AL_051	Gen Breaker Shunt Trip Error	SOFT SHUTDOWN	
AL_052	GEN Negative Phase Current Alarm	ALARM	
AL_053	GEN Negative Phase Current Warning	Disabled	
AL_054	GEN Negative Phase Volt Alarm	ALARM	
AL_055	GEN Negative Phase Volt Warning	Disabled	
AL_056	Gen Over Frequency Alarm	ALARM	
AL_057	Gen Over Frequency Warning	Disabled	
AL_058	Gen Under Frequency Alarm	ALARM	
AL_059	Gen Under Frequency Warning	Disabled	
AL_060	Gen Over Volts Alarm	ALARM	
AL_061	Gen Over Volts Warning	Disabled	
AL_062	Gen Under Volts Alarm	ALARM	
AL_063	Gen Under Volts Warning	Disabled	
AL_064	GEN Over Power Protect Alarm	SOFT SHUTDOWN	
AL_065	GEN Over Power Protect Warning	ALARM	
AL_066	GEN Reverse Power Protect Alarm	SOFT SHUTDOWN	
AL_067	GEN Reverse Power Protect Warning	ALARM	
AL_068	GEN VARS Over Protection Alarm	ALARM	
AL_069	GEN VARS Over Protection Warning	Disabled	
AL_070	GEN VARS Under Protection Alarm	ALARM	
AL_071	GEN VARS Under Protection Warning	Disabled	
AL_072	GEN Phase Differential Current Alarm	ALARM	
AL_073	GEN Phase Differential Current Warning	Disabled	
AL_074	GEN Phase Over Current Alarm	SOFT SHUTDOWN	

AL_075	GEN Phase Over Current Warning	Disabled	
AL_076	KVA Switch Active	Disabled	
AL_077	Speed / Frequency Mismatch	SOFT SHUTDOWN	
AL_078	Phase Rotation Alarm (Sync Inhibit)	SOFT SHUTDOWN	
AL_079	Process Value High Alarm	Disabled	
AL_080	Process Value Low Alarm	Disabled	
AL_081	Voltage Bias Range Alarm	Disabled	
AL_082	Unit Failed to Sync	ALARM	
AL_083	High Load Alarm	Disabled	
AL_084	Low Load Alarm	Disabled	
AL_085	Synchronizer Reclose Attempts Exceeded	Disabled	
AL_086	Not Used	Disabled	
AL_087	Not Used	Disabled	
AL_088	Not Used	Disabled	
AL_089	Not Used	Disabled	
AL_090	Not Used	Disabled	
AL_091	Not Used	Disabled	
AL_092	Not Used	Disabled	
AL_093	Not Used	Disabled	
AL_094	Not Used	Disabled	
AL_095	Not Used	Disabled	
AL_096	Not Used	Disabled	
AL_097	Not Used	Disabled	
AL_098	Not Used	Disabled	
AL_099	Not Used	Disabled	
AL_100	SD initiated from Master GAP file	Disabled	

**EVENTS INITIATED IN THE MASTER GAP (5418-2359)**

Event #	DESCRIPTION	DEFAULT	Site Option
AL_101	Atlas HW/OpSys Summary Fault	HARD SHUTDOWN	
AL_102	Atlas Input Power Alarm	ALARM	
AL_103	Atlas HW Hi Temp	ALARM	
AL_104	Control is NOT Configured	HARD SHUTDOWN	
AL_105	Local Modbus Port #1 Fault	ALARM	
AL_106	Local Modbus Port #2 Fault	Disabled	
AL_107	Remote Modbus Port Fault	Disabled	
AL_108	Speed Signal # 1 Failed	ALARM	
AL_109	Speed Signal # 2 Failed	ALARM	
AL_110	Analog Input # 1 Failed	ALARM	
AL_111	Analog Input # 2 Failed	ALARM	
AL_112	Analog Input # 3 Failed	ALARM	
AL_113	Analog Input # 4 Failed	ALARM	
AL_114	Analog Input # 5 Failed	ALARM	
AL_115	Analog Input # 6 Failed	ALARM	
AL_116	External Discrete E-Stop	HARD SHUTDOWN	HARD SHUTDOWN
AL_117	Spare	Disabled	
AL_118	Spare	Disabled	
AL_119	Event Trigger by DI 04	Disabled	

AL_120	Event Trigger by DI 05	Disabled	
AL_121	Event Trigger by DI 06	Disabled	
AL_122	Event Trigger by DI 07	Disabled	
AL_123	Event Trigger by DI 08	Disabled	
AL_124	Event Trigger by DI 09	Disabled	
AL_125	Event Trigger by DI 10	Disabled	
AL_126	Event Trigger by DI 11	Disabled	
AL_127	Event Trigger by DI 12	Disabled	
AL_128	Event Trigger by DI 13	Disabled	
AL_129	Event Trigger by DI 14	Disabled	
AL_130	Event Trigger by DI 15	Disabled	
AL_131	Event Trigger by DI 16	Disabled	
AL_132	Event Trigger by DI 17	Disabled	
AL_133	Event Trigger by DI 18	Disabled	
AL_134	Event Trigger by DI 19	Disabled	
AL_135	Event Trigger by DI 20	Disabled	
AL_136	Event Trigger by DI 21	Disabled	
AL_137	Event Trigger by DI 22	Disabled	
AL_138	Event Trigger by DI 23	Disabled	
AL_139	Event Trigger by DI 24	Disabled	
AL_140	Speed Signal # 3 Failed	Disabled	
AL_141	Speed Signal # 4 Failed	Disabled	
AL_142	T/C # 01 Signal Failed	ALARM	
AL_143	T/C # 02 Signal Failed	ALARM	
AL_144	T/C # 03 Signal Failed	ALARM	
AL_145	T/C # 04 Signal Failed	ALARM	
AL_146	T/C # 05 Signal Failed	ALARM	
AL_147	T/C # 06 Signal Failed	ALARM	
AL_148	T/C # 07 Signal Failed	ALARM	
AL_149	T/C # 08 Signal Failed	ALARM	
AL_150	T/C # 09 Signal Failed	ALARM	
AL_151	T/C # 10 Signal Failed	ALARM	
AL_152	AI # 07 Signal Failed	ALARM	
AL_153	AI # 08 Signal Failed	ALARM	
AL_154	AI # 09 Signal Failed	ALARM	
AL_155	AI # 10 Signal Failed	ALARM	
AL_156	AI # 11 Signal Failed	ALARM	
AL_157	T/C # 11 Signal Failed	ALARM	
AL_158	T/C # 12 Signal Failed	ALARM	
AL_159	T/C # 13 Signal Failed	Disabled	
AL_160	T/C # 14 Signal Failed	Disabled	
AL_161	T/C # 15 Signal Failed	Disabled	
AL_162	T/C # 16 Signal Failed	Disabled	
AL_163	T/C # 17 Signal Failed	Disabled	
AL_164	T/C # 18 Signal Failed	Disabled	
AL_165	T/C # 19 Signal Failed	Disabled	
AL_166	T/C # 20 Signal Failed	Disabled	
AL_167	AI # 12 Signal Failed	ALARM	
AL_168	AI # 13 Signal Failed	ALARM	
AL_169	AI # 14 Signal Failed	ALARM	

AL_170	AI # 15 Signal Failed	ALARM	
AL_171	AI # 16 Signal Failed	ALARM	
AL_172	Speed Signal #05 Failed	Disabled	
AL_173	Speed Signal #06 Failed	Disabled	
AL_174	CJ Comp Sensor #1 Failed	ALARM	
AL_175	CJ Comp Sensor #2 Failed	ALARM	
AL_176	GAS Fuel Act Failed (Act/SPC/GS)	HARD SHUTDOWN	
AL_177	GAS Act Failed - Unit running on LIQ	ALARM	
AL_178	LIQ Fuel Act Failed (Act/SPC/GS)	HARD SHUTDOWN	
AL_179	LIQ Act Failed - Unit running on Gas	ALARM	
AL_180	SmartCore Module Fault	ALARM	
AL_181	PowerSense Module Fault	ALARM	
AL_182	Analog Combo #1 Module Fault	ALARM	
AL_183	Analog Combo #2 Module Fault	ALARM	
AL_184	Amb Temp Input Failed	ALARM	
AL_185	DevNet - SPC 1 Driver Fault	Disabled	
AL_186	DevNet - SPC 1 Status Fault	Disabled	
AL_187	DevNet - SPC 1 Communication Fault	Disabled	
AL_188	DevNet - SPC 1 Feedback #1 Fault	Disabled	
AL_189	DevNet - SPC 1 Feedback #2 Fault	Disabled	
AL_190	DevNet - SPC 1 Analog Backup Failed	Disabled	
AL_191	DevNet - SPC 2 Driver Fault	Disabled	
AL_192	DevNet - SPC 2 Status Fault	Disabled	
AL_193	DevNet - SPC 2 Communication Fault	Disabled	
AL_194	DevNet - SPC 2 Feedback #1 Fault	Disabled	
AL_195	DevNet - SPC 2 Feedback #2 Fault	Disabled	
AL_196	DevNet - SPC 2 Analog Backup Failed	Disabled	
AL_197	DevNet - SPC 3 Driver Fault	Disabled	
AL_198	DevNet - SPC 3 Status Fault	Disabled	
AL_199	DevNet - SPC 3 Communication Fault	Disabled	
AL_200	DevNet - SPC 3 Feedback #1 Fault	Disabled	
AL_201	DevNet - SPC 3 Feedback #2 Fault	Disabled	
AL_202	DevNet - SPC 3 Analog Backup Failed	Disabled	
AL_203	DevNet - SPC 4 Driver Fault	Disabled	
AL_204	DevNet - SPC 4 Status Fault	Disabled	
AL_205	DevNet - SPC 4 Communication Fault	Disabled	
AL_206	DevNet - SPC 4 Feedback #1 Fault	Disabled	
AL_207	DevNet - SPC 4 Feedback #2 Fault	Disabled	
AL_208	DevNet - SPC 4 Analog Backup Failed	Disabled	
AL_209	DevNet GS Valve 1 Communication Fault	Disabled	
AL_210	DevNet GS Valve 1 System SD	Disabled	
AL_211	DevNet GS Valve 1 Position SD	Disabled	
AL_212	Mismatch of Selected Fuel and Active Fuel	Disabled	
AL_213	Not Used	Disabled	
AL_214	Not Used	Disabled	
AL_215	Not Used	Disabled	
AL_216	Not Used	Disabled	
AL_217	Not Used	Disabled	
AL_218	Not Used	Disabled	
AL_219	Not Used	Disabled	

AL_220	Not Used	Disabled	
AL_221	Not Used	Disabled	
AL_222	Not Used	Disabled	
AL_223	Not Used	Disabled	
AL_224	Not Used	Disabled	
AL_225	Not Used	Disabled	
AL_226	Not Used	Disabled	
AL_227	Not Used	Disabled	
AL_228	Not Used	Disabled	
AL_229	Not Used	Disabled	
AL_230	Not Used	Disabled	
AL_231	Not Used	Disabled	
AL_232	Not Used	Disabled	
AL_233	Not Used	Disabled	
AL_234	Not Used	Disabled	
AL_235	Not Used	Disabled	
AL_236	Not Used	Disabled	
AL_237	Not Used	Disabled	
AL_238	Not Used	Disabled	
AL_239	Not Used	Disabled	
AL_240	Not Used	Disabled	
AL_241	Not Used	Disabled	
AL_242	Not Used	Disabled	
AL_243	Not Used	Disabled	
AL_244	Not Used	Disabled	
AL_245	Not Used	Disabled	
AL_246	Not Used	Disabled	
AL_247	Not Used	Disabled	
AL_248	Not Used	Disabled	
AL_249	Not Used	Disabled	
AL_250	Not Used	Disabled	
AL_251	Customer Event - AI 01 Input Level triggered	Disabled	
AL_252	Customer Event - AI 02 Input Level triggered	Disabled	
AL_253	Customer Event - AI 03 Input Level triggered	Disabled	
AL_254	Customer Event - AI 04 Input Level triggered	Disabled	
AL_255	Customer Event - AI 05 Input Level triggered	Disabled	
AL_256	Customer Event - AI 06 Input Level triggered	Disabled	
AL_257	Customer Event - AI 07 Input Level triggered	Disabled	
AL_258	Customer Event - AI 08 Input Level triggered	Disabled	
AL_259	Customer Event - AI 09 Input Level triggered	Disabled	
AL_260	Customer Event - AI 10 Input Level triggered	Disabled	
AL_261	Customer Event - AI 11 Input Level triggered	Disabled	
AL_262	Customer Event - AI 12 Input Level triggered	Disabled	
AL_263	Customer Event - AI 13 Input Level triggered	Disabled	
AL_264	Customer Event - AI 14 Input Level triggered	Disabled	
AL_265	Customer Event - AI 15 Input Level triggered	Disabled	
AL_266	Customer Event - AI 16 Input Level triggered	Disabled	
AL_267	Not Used	Disabled	
AL_268	Not Used	Disabled	
AL_269	Not Used	Disabled	

AL_270	Not Used	Disabled	
AL_271	Not Used	Disabled	
AL_272	Not Used	Disabled	
AL_273	Not Used	Disabled	
AL_274	Not Used	Disabled	
AL_275	Not Used	Disabled	
AL_276	Not Used	Disabled	
AL_277	Not Used	Disabled	
AL_278	Not Used	Disabled	
AL_279	Not Used	Disabled	
AL_280	Not Used	Disabled	
AL_281	Not Used	Disabled	
AL_282	Not Used	Disabled	
AL_283	Not Used	Disabled	
AL_284	Not Used	Disabled	
AL_285	Not Used	Disabled	
AL_286	Not Used	Disabled	
AL_287	Not Used	Disabled	
AL_288	Not Used	Disabled	
AL_289	Not Used	Disabled	
AL_290	Not Used	Disabled	
AL_291	Not Used	Disabled	
AL_292	Not Used	Disabled	
AL_293	Not Used	Disabled	
AL_294	Not Used	Disabled	
AL_295	Not Used	Disabled	
AL_296	Not Used	Disabled	
AL_297	Not Used	Disabled	
AL_298	Not Used	Disabled	
AL_299	Not Used	Disabled	
AL_300	Not Used	Disabled	

\*\* There are additional Latch blocks that can be used to capture Alarm and Shutdown events triggered from Multiprog logic. These blocks all have 400 inputs available with an offset of 300 on the First Out indication.



# Appendix D. Configuration and Service Tunables Worksheet



Control Part Number \_\_\_\_\_

Software Number & Revision Letter \_\_\_\_\_

Control Serial Number \_\_\_\_\_

**I/O CONFIGURATION NOTES**

**MPUs:**

MPUs: Maximum frequency sensing = 25000 Hz  
Single or up to 4 Redundant Sensors

**TEMPERATURE INPUT (summary input):**

EGT: input in Deg. F, 4-20mA – Required on Analog Input Channel # 6 if not T/C's

**COMPRESSOR DISCHARGE PRESSURE INPUT:**

CDP: input in psia, 4-20mA – If used must be on Analog Input Channel # 7

**SERVICE & CONFIGURATION HEADER NOTES:**

Below is a list of the Quickservice Inspector File that is used to configure the control. Each Tab sheet is listed below with a column available for the user to record the correct value for their unit.

The column identify by the T \* indicates that rows value as tunable.

## Configure Sheets

The following section outlines optional configurations that can be adjusted in this standard control. These should be checked at the site to be sure they are correct for the turbine being controlled. The default value and range are shown for each tunable. The turbine must be shutdown to adjust the tunables in Configure mode, as it will place the control in IO LOCK.

```
*****
** LIST OF CONFIGURE SHEET TAB HEADERS **
*****
** CONFIGURE: C1- A - SYSTEM **
** CONFIGURE: C2- B - Psense SETTINGS**
** CONFIGURE: C3- C - SPEED SENSOR SETTINGS**
** CONFIGURE: C4- D - ANALOG IN OPTS (4=MAX)**
** CONFIGURE: C5- E - EGT TYPE**
** CONFIGURE: C6- F - EGT SETTINGS**
```

**Configure: A - SYSTEM**

Category	Field Name	Value	Low	High	User Value
Configure	01 Use Gas Fuel Valve	* TRUE			
Configure	02 Gas Valve Reverse Act?	* FALSE			

Configure	03 Use Liq Fuel Valve	*	TRUE			
Configure	04 Liq Valve Reverse Act?	*	FALSE			
Configure	05 PT Idle Speed Ref (Min)	*	2250	100	20000	
Configure	06 PT Rated Speed	*	3600	100	20000	
Configure	07 PT Max Spd Ref Setpoint	*	3780	1000	30000	
Configure	08 PT Speed for SD Reset	*	500	100	30000	
Configure	09 Flame Detect Options	*	1	1	3	
Configure	10 Flame Detect Option Fdbk		EGT > 400 Deg F			
Configure	11 Num of Flame Detectors	*	2	1	4	
Configure	12 Num FlamDet Requird	*	1	1	4	
Configure	13 Disable CDP Sensor	*	FALSE			
Configure	14 Fuel Transfer Rate (sec)	*	60	10	120	
Configure	15 Gen Freq (1=50, 2=60) HZ	*	2	1	2	
Configure	16 Use Sync/Breaker Ccmds?	*	TRUE			
Configure	17 Init Mode at Brkr Close	*	0	0	2	
Configure	18 Initial Mode Selected		Manual Loading			
Configure	19 Use Load Sharing by LON?	*	FALSE			
Configure	20 Use Reactive Load Cntrl?	*	TRUE			
Configure	21 Display Temps in Deg C	*	FALSE			
Configure	22 SD BO True=SD	*	TRUE			
Configure	23 ALM Out Summary or Horn	*	FALSE			
Configure	24 Tune True= CNFGComplete	*	FALSE			

**Configure: B - PSense SETTINGS**

Category	Field Name		Value	Low	High	User Value
Configure	01 GEN CT Ratio	*	150	5	30000	
Configure	02 GEN PT Ratio	*	5	1	1000	
Configure	03 GEN Sensing Type T=3 Phz	*	TRUE			
Configure	04 GEN H/W Volt(70/120/240)	*	2	1	3	
Configure	05 Mains CT Ratio	*	150	5	30000	
Configure	06 Mains PT Ratio	*	5	1	1000	
Configure	07 Mains Sensing Type (T=3)	*	TRUE			
Configure	08 Mains H/W Vlt 70/120/240	*	2	1	3	
Configure	09 Num of Poles in GEN	*	2	2	18	
Configure	10 Rated GEN KVA	*	125	1	300	
Configure	11 Rated GEN KVAR	*	25	0.1	300	
Configure	12 Rated GEN KW	*	50	0.1	300	
Configure	13 Rated GEN Volt	*	480	0.001	30000	
Configure	14 GEN Line Config 1=Delta	*	1	1	2	
Configure	15 GEN Rotation (T=ABC)	*	TRUE			
Configure	16 Rated Mains KVA	*	1000	10	30000	
Configure	17 Rated Mains KVAR	*	1000	0.001	30000	
Configure	18 Rated Mains KW	*	10000	0.001	30000	
Configure	19 Rated Mains Volts	*	480	0.001	30000	
Configure	20 Mains Line Config (2=Y)	*	1	1	2	
Configure	21 Voltage Bias Type	*	3	1	5	
Configure	22 Voltage Bias Selected		+/- 3 Volt			
Configure	23 LON Unit Number	*	1	1	16	

**Configure: C - SPEED SENSOR SETTINGS**

Category	Field Name	Value	Low	High	User Value
Configure	01 Number of Sensors	* 1	1	4	
Configure	02 Max Shaft Speed	* 5000	0	30000	
Configure	03 Speed Gear Ratio	* 1	0.01	100	
Configure	04 Number of Gear Teeth	* 83	1	1000	
Configure	05 Spd Failed High Setpoint	* 5000	0	30000	
Configure	06 Spd Failed Low Setpoint	* 300	0	30000	
Configure	07 Snsr Spread Alarm Level	* 1000	0	30000	
Configure	08 Hi Speed Alarm Setpnt	* 4000	100	10000	
Configure	09 Overspeed SD Setpoint	* 4000	100	10000	

**Configure: D - ANALOG IN OPTS**

Category	Field Name	Value	Low	High	User Value
Configure	00 Tune Value to 1 to Use	Function Shown			
Configure	01 Process Control Signal	* 1	0	2	
Configure	02 Remote PT Speed REF	* 1	0	2	
Configure	03 Remote Process Setpoint	* 1	0	2	
Configure	04 Amb Inlet Air Temp	* 1	0	2	
Configure	05 Remote VAR/PF REF	* 1	0	2	
Configure	06 EGT as a Summary AI	* 1	0	2	
Configure	07 CDP Sensor A	* 1	0	2	
Configure	08 Remote MW Setpoint	* 0	0	2	
Configure	09 P1 Gas Pressure Sensor	* 0	0	2	
Configure	10 P2 Gas Pressure Sensor A	* 0	0	2	
Configure	11 P2 Gas Pressure Sensor B	* 0	0	2	
Configure	12 CDP Sensor B	* 0	0	2	
Configure	13 Analog Flame Detector 1	* 1	0	2	
Configure	14 Analog Flame Detector 2	* 1	0	2	
Configure	15 Analog Flame Detector 3	* 1	0	2	
Configure	16 Analog Flame Detector 4	* 1	0	2	

**Configure: E - EGT TYPE**

Category	Field Name	Value	Low	High	User Value
Configure	01 EGT Configuration	* 3	1	3	
Configure	02 EGT Selected Input	Individual T/C			
Configure	03 Use EGT TC01	* TRUE			
Configure	04 Use EGT TC02	* TRUE			
Configure	05 Use EGT TC03	* TRUE			
Configure	06 Use EGT TC04	* TRUE			
Configure	07 Use EGT TC05	* TRUE			
Configure	08 Use EGT TC06	* TRUE			
Configure	09 Use EGT TC07	* TRUE			
Configure	10 Use EGT TC08	* TRUE			
Configure	11 Use EGT TC09	* TRUE			
Configure	12 Use EGT TC10	* TRUE			

Configure	13 Use EGT TC11	*	TRUE			
Configure	14 Use EGT TC12	*	TRUE			
Configure	15 Use EGT TC13	*	FALSE			
Configure	16 Use EGT TC14	*	FALSE			
Configure	17 Use EGT TC15	*	FALSE			
Configure	18 Use EGT TC16	*	FALSE			
Configure	19 Use EGT TC17	*	FALSE			
Configure	20 Use EGT TC18	*	FALSE			

**Configure: F - EGT SETTINGS**

Category	Field Name		Value	Low	High	User Value
Configure	01 EGT Low Temp Setpnt	*	500	-100	2500	
Configure	02 EGT Overtemp Alm Setpnt	*	1600	0	2500	
Configure	03 EGT Overtemp SD Setpnt	*	1650	0	2500	
Configure	04 Number of T/C Used	*	8	0	18	
Configure	05 ALM/SD if 3 Adj T/C Fail	*	TRUE			
Configure	06 Trip if # of T/C Failed	*	5	0	18	
Configure	07 Trip is T/C Spread is GT	*	400	0	5000	
Configure	08 T/C Mon block Low Delta	*	200	50	2000	
Configure	09 T/C Mon block High Delta	*	200	50	2000	

## Service Sheets

The following section outlines Optional configurations that can be adjusted in this standard control. These should be checked at the site to be sure they are correct for the turbine being controlled. The default value and range are shown for each tunable. In Service mode, these are values that can be adjusted without shutting down the turbine, however, caution should always be used when making on-line adjustments.

```

*****
** LIST OF SERVICE SHEET TAB HEADERS **
*****
** SERVICE: S01 AI 1 Setup **
** SERVICE: S02 AI 2 Setup **
** SERVICE: S03 AI 3 Setup **
** SERVICE: S04 AI 4 Setup **
** SERVICE: S05 AI 5 Setup **
** SERVICE: S06 AI 6 Setup **
** SERVICE: S07 AI 7 Setup **
** SERVICE: S08 AI 8 Setup **
** SERVICE: S09 AI 9 Setup **
** SERVICE: S10 AI 10 Setup **
** SERVICE: S11 AI 11 Setup **
** SERVICE: S12 AI 12 Setup **
** SERVICE: S13 AI 13 Setup **
** SERVICE: S14 AI 14 Setup **
** SERVICE: S15 AI 15 Setup **
** SERVICE: S16 AI 16 Setup **
** SERVICE: S17 T/C 1-7 Setup **
** SERVICE: S18 T/C 8-14 Setup **
** SERVICE: S19 T/C 15-20 Setup **
** SERVICE: S20 DI 1-6 Setup **
** SERVICE: S21 DI 7-11 Setup **
** SERVICE: S22 DI 12-16 Setup **
** SERVICE: S23 DI 17-21 Setup **
    
```

\*\* SERVICE: S24 DI 22-24 Setup \*\*  
 \*\* SERVICE: S25 DO 3-7 Setup \*\*  
 \*\* SERVICE: S26 DO 8-12 Setup \*\*  
 \*\* SERVICE: S27 AO 1-4 Setup\*\*  
 \*\* SERVICE: S28 AO 5-8 Setup \*\*  
 \*\* SERVICE: S29 AO 9-10 Setup \*\*  
 \*\* SERVICE: S30 PowerSense Module Setup \*\*  
 \*\* SERVICE: S31 Relay Output Forcing \*\*  
 \*\* SERVICE: S32 Analog Output Forcing \*\*  
 \*\* SERVICE: S33 Analog Output Forcing \*\*  
 \*\* SERVICE: S34 Valve Calibration & Stroke \*\*  
 \*\* SERVICE: S35 Start / Lite-off Setup \*\*  
 \*\* SERVICE: S36 Start/Stop Sequence \*\*  
 \*\* SERVICE: S37 Remote Speed Reference Setup \*\*  
 \*\* SERVICE: S38 Speed Control Setup \*\*  
 \*\* SERVICE: S39 EGT Control PID Setup \*\*  
 \*\* SERVICE: S40 Real Load Control Setup \*\*  
 \*\* SERVICE: S41 Synchronizer Setup \*\*  
 \*\* SERVICE: S42 Reactive Load Setup \*\*  
 \*\* SERVICE: S43 Process Control Setup \*\*  
 \*\* SERVICE: S44 Generator Protection 1 \*\*  
 \*\* SERVICE: S45 Generator Protection 2 \*\*

**Service: S01 AI 1 setup**

Category	Field Name	Value	Low	High	User Value
Service	01 Select Function for AI01	1			
		Process Control Input Signal			
Service	02 Mode =				
Service	03 1=4-20mA 2=0-5V	* 1	1	2	
		Channel configured as 4-20 mA			
Service	04 Mode =				
Service	05 Analog 1 Value @ 4 mA =	* 0	-20000	20000	
Service	06 Analog 1 Value @ 20 mA =	* 100	-80000	80000	
Service	07 Analog 1 Value	-0.1			
Service	08 Analog 1 Offset	* 0	-487500	487500	
Service	09 Analog 1 Gain	* 1	0	2	
Service	10 Failed sensor delay time	* 0.1	0	5	
Service	11 Configurd for Custom Sig	FALSE			
Service	12 Custom Use Event Level	* 1000	-15000	15000	
Service	13 Alarm Low=T Hi=F	* FALSE			
		Alarm on rising signal (High)			
Service	14 Mode =				
Service	15 1=N Used 2=Alrm 3=SD	* 1	1	4	
Service	16 Mode =	Disabled			
Service	17 Alarm delay time	* 0.1	0	500	
Service	18 Action on Failed Signal	* 2	1	5	
Service	19 Mode =	Alarm			

**Service: S02 AI 2 setup**

Category	Field Name	Value	Low	High	User Value
Service	01 Select Function for AI02	1			
		Remote PT Speed Ref			
Service	02 Mode =				
Service	03 1=4-20mA 2=0-5V	* 1	1	2	

Service	04 Mode =	Channel configured as 4-20 mA			
Service	05 Analog 2 Value @ 4 mA =	* 3600	-20000	20000	
Service	06 Analog 2 Value @ 20 mA =	* 3780	-80000	80000	
Service	07 Analog 2 Value	3599.88			
Service	08 Analog 2 Offset	* 0	-487500	487500	
Service	09 Analog 2 Gain	* 1	0	2	
Service	10 Failed sensor delay time	* 0.1	0	5	
Service	11 Configurd for Custom Sig	FALSE			
Service	12 Custom Use Event Level	* 1000	-15000	15000	
Service	13 Alarm Low=T Hi=F	* FALSE			
Service	14 Mode =	Alarm on rising signal (High)			
Service	15 1=N_Used 2=Alrm 3=SD	* 1	1	4	
Service	16 Mode =	Disabled			
Service	17 Alarm delay time	* 0.1	0	500	
Service	18 Action on Failed Signal	* 2	1	5	
Service	19 Mode =	Alarm			

**Service: S03 AI 3 setup**

Category	Field Name	Initial Val	Low	High	User Value
Service	01 Select Function for AI03	1			
		Remote Process Control Setpoint			
Service	02 Mode =				
Service	03 1=4-20mA 2=0-5V	* 1	1	2	
Service	04 Mode =	Channel configured as 4-20 mA			
Service	05 Analog 3 Value @ 4 mA =	* 0	-20000	20000	
Service	06 Analog 3 Value @ 20 mA =	* 30	-80000	80000	
Service	07 Analog 3 Value	0			
Service	08 Analog 3 Offset	* 0	-487500	487500	
Service	09 Analog 3 Gain	* 1	0	2	
Service	10 Failed sensor delay time	* 0.1	0	5	
Service	11 Configurd for Custom Sig	FALSE			
Service	12 Custom Use Event Level	* 1000	-15000	15000	
Service	13 Alarm Low=T Hi=F	* FALSE			
Service	14 Mode =	Alarm on rising signal (High)			
Service	15 1=N_Used 2=Alrm 3=SD	* 1	1	4	
Service	16 Mode =	Disabled			
Service	17 Alarm delay time	* 0.1	0	500	
Service	18 Action on Failed Signal	* 2	1	5	
Service	19 Mode =	Alarm			

**Service: S04 AI 4 setup**

Category	Field Name	Value	Low	High	User Value
Service	01 Select Function for AI04	1			

Service	02 Mode =	Ambient Turbine Inlet Temp			
Service	03 1=4-20mA 2=0-5V	* 1	1	2	
Service	04 Mode =	Channel configured as 4-20 mA			
Service	05 Analog 4 Value @ 4 mA =	* 0	-20000	20000	
Service	06 Analog 4 Value @ 20 mA =	* 100	-80000	80000	
Service	07 Analog 4 Value	-0.39			
Service	08 Analog 4 Offset	* 0	-487500	487500	
Service	09 Analog 4 Gain	* 1	0	2	
Service	10 Failed sensor delay time	* 0.1	0	5	
Service	11 Configurd for Custom Sig	FALSE			
Service	12 Custom Use Event Level	* 1000	-15000	15000	
Service	13 Alarm Low=T Hi=F	* FALSE			
Service	14 Mode =	Alarm on rising signal (High)			
Service	15 1=N Used 2=Alrm 3=SD	* 1	1	4	
Service	16 Mode =	Disabled			
Service	17 Alarm delay time	* 0.1	0	500	
Service	18 Action on Failed Signal	* 2	1	5	
Service	19 Mode =	Alarm			

**Service: S05 AI 5 setup**

Category	Field Name	Value	Low	High	User Value
Service	01 Select Function for AI05	1			
Service	02 Mode =	Remote VAR/PF Reference			
Service	03 1=4-20mA 2=0-5V	* 1	1	2	
Service	04 Mode =	Channel configured as 4-20 mA			
Service	05 Analog 5 Value @ 4 mA =	* -40	-20000	20000	
Service	06 Analog 5 Value @ 20 mA =	* 140	-80000	80000	
Service	07 Analog 5 Value	58.79			
Service	08 Analog 5 Offset	* 0	-487500	487500	
Service	09 Analog 5 Gain	* 1	0	2	
Service	10 Failed sensor delay time	* 0.1	0	5	
Service	11 Configurd for Custom Sig	FALSE			
Service	12 Custom Use Event Level	* 1000	-15000	15000	
Service	13 Alarm Low=T Hi=F	* FALSE			
Service	14 Mode =	Alarm on rising signal (High)			
Service	15 1=N Used 2=Alrm 3=SD	* 1	1	4	
Service	16 Mode =	Disabled			
Service	17 Alarm delay time	* 0.1	0	500	
Service	18 Action on Failed Signal	* 2	1	5	
Service	19 Mode =	Alarm			

**Service: S06 AI 6 setup**

Category	Field Name	Value	Low	High	User Value
Service	01 Select Function for AI06	1			
		EGT Signal (if 4-20 Summary used)			
Service	02 Mode =				
Service	03 1=4-20mA 2=0-5V	* 1	1	2	
		Channel configured as 4-20 mA			
Service	04 Mode =				
Service	05 Analog 6 Value @ 4 mA =	* 0	-20000	20000	
Service	06 Analog 6 Value @ 20 mA =	* 2000	-80000	80000	
Service	07 Analog 6 Value	58.11			
Service	08 Analog 6 Offset	* 0	-487500	487500	
Service	09 Analog 6 Gain	* 1	0	2	
Service	10 Failed sensor delay time	* 0.1	0	5	
Service	11 Configurd for Custom Sig	FALSE			
Service	12 Custom Use Event Level	* 1000	-15000	15000	
Service	13 Alarm Low=T Hi=F	* FALSE			
		Alarm on rising signal (High)			
Service	14 Mode =				
Service	15 1=N_Used 2=Alrm 3=SD	* 1	1	4	
Service	16 Mode =	Disabled			
Service	17 Alarm delay time	* 0.1	0	500	
Service	18 Action on Failed Signal	* 2	1	5	
Service	19 Mode =	Alarm			

**Service: S07 AI 7 setup**

Category	Field Name	Value	Low	High	User Value
Service	01 0=n used 1=GTC 2=Cust	1			
		Compressor Discharge Pressure A			
Service	02 Mode =				
Service	03 Analog 7 Value @ 4 mA =	* -40	-20000	20000	
Service	04 Analog 7 Value @ 20 mA =	* 140	-20000	20000	
Service	05 Analog 7 Value	-40.09			
Service	06 Analog 7 Offset	* 0	-487500	487500	
Service	07 Analog 7 Gain	* 1	0	2	
Service	08 Failed sensor delay time	* 0.1	0	5	
Service	09 Custom Use Event Level	* 1000	-15000	15000	
Service	10 Alarm Low=T Hi=F	* FALSE			
		Alarm on rising signal (High)			
Service	11 Mode =				
Service	12 Select Action on Event	* 1	1	4	
Service	13 Mode =	Disabled			
Service	14 Alarm delay time	* 0.1	0	500	
Service	15 SNSR FLT T=SD F=Alrm	* 2	1	5	
Service	16 Mode =	Alarm			

**Service: S08 AI 8 setup**

Category	Field Name	Value	Low	High	User Value
----------	------------	-------	-----	------	------------



Value

Service	01 0=n used 1=GTC 2=Cust	0			
Service	02 Mode =	Not Used			
Service	03 Analog 8 Value @ 4 mA =	* 0	-20000	20000	
Service	04 Analog 8 Value @ 20 mA =	* 100	-20000	20000	
Service	05 Analog 8 Value	0.01			
Service	06 Analog 8 Offset	* 0	-487500	487500	
Service	07 Analog 8 Gain	* 1	0	2	
Service	08 Failed sensor delay time	* 0.1	0	5	
Service	09 Custom Use Event Level	* 1000	-15000	15000	
Service	10 Alarm Low=T Hi=F	* FALSE			
Service	11 Mode =	Alarm on rising signal (High)			
Service	12 Select Action on Event	* 1	1	4	
Service	13 Mode =	Disabled			
Service	14 Alarm delay time	* 0.1	0	500	
Service	15 SNSR FLT T=SD F=Alrm	* 2	1	5	
Service	16 Mode =	Alarm			

**Service: S09 AI 9 setup**

Category	Field Name	Value	Low	High	User Value
Service	01 0=n used 1=GTC 2=Cust	0			
Service	02 Mode =	Not Used			
Service	03 Analog 9 Value @ 4 mA =	* 0	-20000	20000	
Service	04 Analog 9 Value @ 20 mA =	* 100	-20000	20000	
Service	05 Analog 9 Value	0.01			
Service	06 Analog 9 Offset	* 0	-487500	487500	
Service	07 Analog 9 Gain	* 1	0	2	
Service	08 Failed sensor delay time	* 0.1	0	5	
Service	09 Custom Use Event Level	* 1000	-15000	15000	
Service	10 Alarm Low=T Hi=F	* FALSE			
Service	11 Mode =	Alarm on rising signal (High)			
Service	12 Select Action on Event	* 1	1	4	
Service	13 Mode =	Disabled			
Service	14 Alarm delay time	* 0.1	0	500	
Service	15 SNSR FLT T=SD F=Alrm	* 2	1	5	
Service	16 Mode =	Alarm			

**Service: S10 AI 10 setup**

Category	Field Name	Value	Low	High	User Value
Service	01 0=n used 1=GTC 2=Cust	0			
Service	02 Mode =	Not Used			
Service	03 Analog 10 Value @ 4 mA =	* 0	-20000	20000	
Service	04 Analog 10 Value @ 20 mA =	* 100	-20000	20000	
Service	05 Analog 10 Value	0			
Service	06 Analog 10 Offset	* 0	-100	100	
Service	07 Analog 10 Gain	* 1	0	2	

Service	08 Failed sensor delay time	*	0.1	0	5	
Service	09 Custom Use Event Level	*	1000	-15000	15000	
Service	10 Alarm Low=T Hi=F	*	FALSE			
Service	11 Mode =		Alarm on rising signal (High)			
Service	12 Select Action on Event	*	1	1	4	
Service	13 Mode =		Disabled			
Service	14 Alarm delay time	*	0.1	0	500	
Service	15 SNSR FLT T=SD F=Alrm	*	2	1	5	
Service	16 Mode =		Alarm			

**Service: S11 AI 11 setup**

Category	Field Name		Value	Low	High	User Value
Service	01 0=n used 1=GTC 2=Cust		0			
Service	02 Mode =		Not Used			
Service	03 Analog 11 Value @ 4 mA =	*	0	-20000	20000	
Service	04 Analog 11 Value@ 20 mA =	*	500	-20000	20000	
Service	05 Analog 11 Value		13.54			
Service	06 Analog 11 Offset	*	0	-487500	487500	
Service	07 Analog 11 Gain	*	1	0	2	
Service	08 Failed sensor delay time	*	0.1	0	5	
Service	09 Custom Use Event Level	*	1000	-15000	15000	
Service	10 Alarm Low=T Hi=F	*	FALSE			
Service	11 Mode =		Alarm on rising signal (High)			
Service	12 Select Action on Event	*	1	1	4	
Service	13 Mode =		Disabled			
Service	14 Alarm delay time	*	0.1	0	500	
Service	15 SNSR FLT T=SD F=Alrm	*	2	1	5	
Service	16 Mode =		Alarm			

**Service: S12 AI 12 setup**

Category	Field Name		Value	Low	High	User Value
Service	01 0=n used 1=GTC 2=Cust		0			
Service	02 Mode =		Not Used			
Service	03 Analog 12 Value @ 4 mA =	*	0	-20000	20000	
Service	04 Analog 12 Value@ 20 mA =	*	100	-20000	20000	
Service	05 Analog 12 Value		0			
Service	06 Analog 12 Offset	*	0	-487500	487500	
Service	07 Analog 12 Gain	*	1	0	2	
Service	08 Failed sensor delay time	*	0.1	0	5	
Service	09 Custom Use Event Level	*	1000	-15000	15000	
Service	10 Alarm Low=T Hi=F	*	FALSE			
Service	11 Mode =		Alarm on rising signal (High)			
Service	12 Select Action on Event	*	1	1	4	
Service	13 Mode =		Disabled			
Service	14 Alarm delay time	*	0.1	0	500	

Service	15 SNSR FLT T=SD F=Alrm	* 2	1	5	
Service	16 Mode =	Alarm			

**Service: S13 AI 13 setup**

Category	Field Name	Value	Low	High	User Value
Service	01 0=n used 1=GTC 2=Cust	1			
		Analog Flame Detector A (1)			
Service	02 Mode =				
Service	03 Analog 13 Value @ 4 mA =	* 4	-20000	20000	
Service	04 Analog 13 Value@ 20 mA =	* 20	-20000	20000	
Service	05 Analog 13 Value	4			
Service	06 Analog 13 Offset	* 0	-487500	487500	
Service	07 Analog 13 Gain	* 1	0	2	
Service	08 Failed sensor delay time	* 0.1	0	5	
Service	09 Custom Use Event Level	* 1000	-15000	15000	
Service	10 Alarm Low=T Hi=F	* FALSE			
		Alarm on rising signal (High)			
Service	11 Mode =				
Service	12 Select Action on Event	* 1	1	4	
Service	13 Mode =	Disabled			
Service	14 Alarm delay time	* 0.1	0	500	
Service	15 SNSR FLT T=SD F=Alrm	* 2	1	5	
Service	16 Mode =	Alarm			

**Service: S14 AI 14 setup**

Category	Field Name	Value	Low	High	User Value
Service	01 0=n used 1=GTC 2=Cust	1			
		Analog Flame Detector B (2)			
Service	02 Mode =				
Service	03 Analog 14 Value @ 4 mA =	* 4	-20000	20000	
Service	04 Analog 14 Value@ 20 mA =	* 20	-20000	20000	
Service	05 Analog 14 Value	24.08			
Service	06 Analog 14 Offset	* 0	-487500	487500	
Service	07 Analog 14 Gain	* 1	0	2	
Service	08 Failed sensor delay time	* 0.1	0	5	
Service	09 Custom Use Event Level	* 1000	-15000	15000	
Service	10 Alarm Low=T Hi=F	* FALSE			
		Alarm on rising signal (High)			
Service	11 Mode =				
Service	12 Select Action on Event	* 1	1	4	
Service	13 Mode =	Disabled			
Service	14 Alarm delay time	* 0.1	0	500	
Service	15 SNSR FLT T=SD F=Alrm	* 2	1	5	
Service	16 Mode =	Alarm			

**Service: S15 AI 15 setup**

Category	Field Name	Value	Low	High	User Value
Service	01 0=n used 1=GTC 2=Cust	1			
		Analog Flame Detector C (3)			
Service	02 Mode =				
Service	03 Analog 15 Value @ 4 mA =	* 4	-20000	20000	
Service	04 Analog 15 Value@ 20 mA =	* 20	-20000	20000	
Service	05 Analog 15 Value	6.18			
Service	06 Analog 15 Offset	* 0	-487500	487500	
Service	07 Analog 15 Gain	* 1	0	2	
Service	08 Failed sensor delay time	* 0.1	0	5	
Service	09 Custom Use Event Level	* 1000	-15000	15000	
Service	10 Alarm Low=T Hi=F	* FALSE			
		Alarm on rising signal (High)			
Service	11 Mode =				
Service	12 Select Action on Event	* 1	1	4	
Service	13 Mode =	Disabled			
Service	14 Alarm delay time	* 0.1	0	500	
Service	15 SNSR FLT T=SD F=Alrm	* 2	1	5	
Service	16 Mode =	Alarm			

**Service: S16 AI 16 setup**

Category	Field Name	Value	Low	High	User Value
Service	01 0=n used 1=GTC 2=Cust	1			
		Analog Flame Detector D (4)			
Service	02 Mode =				
Service	03 Analog 16 Value @ 4 mA =	* 4	-20000	20000	
Service	04 Analog 16 Value@ 20 mA =	* 20	-20000	20000	
Service	05 Analog 16 Value	4.42			
Service	06 Analog 16 Offset	* 0	-487500	487500	
Service	07 Analog 16 Gain	* 1	0	2	
Service	08 Failed sensor delay time	* 0.1	0	5	
Service	09 Custom Use Event Level	* 1000	-15000	15000	
Service	10 Alarm Low=T Hi=F	* FALSE			
		Alarm on rising signal (High)			
Service	11 Mode =				
Service	12 Select Action on Event	* 1	1	4	
Service	13 Mode =	Disabled			
Service	14 Alarm delay time	* 0.1	0	500	
Service	15 SNSR FLT T=SD F=Alrm	* 2	1	5	
Service	16 Mode =	Alarm			

**Service: S17 T/C 1-7 SETUP**

Category	Field Name	Value	Low	High	User Value
Service	01T/C 01 Input Value	172.27			
Service	02 T/C 01 Offset	* 0	-200	200	
Service	03 T/C 01 Gain	* 1	0.8	1.2	

Service	04 T/C 02 Input Value	57.17			
Service	05 T/C 02 Offset	* 0	-200	200	
Service	06 T/C 02 Gain	* 1	0.8	1.2	
Service	07 T/C 03 Input Value	55.77			
Service	08 T/C 03 Offset	* 0	-200	200	
Service	09 T/C 03 Gain	* 1	0.8	1.2	
Service	10 T/C 04 Input Value	55.57			
Service	11 T/C 04 Offset	* 0	-200	200	
Service	12 T/C 04 Gain	* 1	0.8	1.2	
Service	13 T/C 05 Input Value	58.96			
Service	14 T/C 05 Offset	* 0	-200	200	
Service	15 T/C 05 Gain	* 1	0.8	1.2	
Service	16 T/C 06 Input Value	53.78			
Service	17 T/C 06 Offset	* 0	-200	200	
Service	18 T/C 06 Gain	* 1	0.8	1.2	
Service	19 T/C 07 Input Value	64.45			
Service	20 T/C 07 Offset	* 0	-200	200	
Service	21 T/C 07 Gain	* 1	0.8	1.2	

**Service: S18 T/C 8-14 SETUP**

Category	Field Name	Value	Low	High	User Value
Service	01 T/C 08 Input Value	61.85			
Service	02 T/C 08 Offset	* 0	-200	200	
Service	03 T/C 08 Gain	* 1	0.8	1.2	
Service	04 T/C 09 Input Value	57.76			
Service	05 T/C 09 Offset	* 0	-200	200	
Service	06 T/C 09 Gain	* 1	0.8	1.2	
Service	07 T/C 10 Input Value	72.11			
Service	08 T/C 10 Offset	* 0	-200	200	
Service	09 T/C 10 Gain	* 1	0.8	1.2	
Service	10 T/C 11 Input Value	61.25			
Service	11 T/C 11 Offset	* 0	-200	200	
Service	12 T/C 11 Gain	* 1	0.8	1.2	
Service	13 T/C 12 Input Value	66.64			
Service	14 T/C 12 Offset	* 0	-200	200	
Service	15 T/C 12 Gain	* 1	0.8	1.2	
Service	16 T/C 13 Input Value	56.47			
Service	17 T/C 13 Offset	* 0	-200	200	
Service	18 T/C 13 Gain	* 1	0.8	1.2	
Service	19 T/C 14 Input Value	60.86			
Service	20 T/C 14 Offset	* 0	-200	200	
Service	21 T/C 14 Gain	* 1	0.8	1.2	

**Service: S19 T/C 15-20 SETUP**

Category	Field Name	Value	Low	High	User Value
Service	01 T/C 15 Input Value	59.26			
Service	02 T/C 15 Offset	* 0	-200	200	
Service	03 T/C 15 Gain	* 1	0.8	1.2	
Service	04 T/C 16 Input Value	63.45			

Service	05 T/C 16 Offset	* 0	-200	200	
Service	06 T/C 16 Gain	* 1	0.8	1.2	
Service	07 T/C 17 Input Value		-443.11		
Service	08 T/C 17 Offset	* 0	-200	200	
Service	09 T/C 17 Gain	* 1	0.8	1.2	
Service	10 T/C 18 Input Value		-443.11		
Service	11 T/C 18 Offset	* 0	-200	200	
Service	12 T/C 18 Gain	* 1	0.8	1.2	
Service	13 T/C 19 Input Value		-443.11		
Service	14 T/C 19 Offset	* 0	-200	200	
Service	15 T/C 19 Gain	* 1	0.8	1.2	
Service	16 T/C 20 Input Value		-443.11		
Service	17 T/C 20 Offset	* 0	-200	200	
Service	18 T/C 20 Gain	* 1	0.8	1.2	

**Service: S20 DI 1-6 Setup**

Category	Field Name	Value	Low	High	User Value
Service	01 DI01 T=NO F=NC	* TRUE			
Service	02 Mode =	Normally open switch			
Service	03 DI02 T=NO F=NC	* FALSE			
Service	04 Mode =	Normally closed switch			
Service	05 DI03 T=NO F=NC	* FALSE			
Service	06 Mode =	Normally closed switch			
Service	07 DI04 F=GTC T=Customer	* FALSE			
Service	08 Mode =	System Acknowledge (ALM & SD)			
Service	09 DI04 T=NO F=NC	* FALSE			
Service	10 Mode =	Normally closed switch			
Service	11 DI05 F=GTC T=Customer	* FALSE			
Service	12 Mode =	PT Reference Lower Command			
Service	13 DI05 T=NO F=NC	* FALSE			
Service	14 Mode =	Normally closed switch			
Service	15 Use PERM, ALM, SD?	* 5	1	5	
Service	16 DI06 F=GTC T=Customer	* FALSE			
Service	17 Mode =	PT Reference Raise Command			
Service	18 DI06 T=NO F=NC	* FALSE			
Service	19 Mode =	Normally closed switch			

Service	20 Use PERM, ALM, SD?	*	5	1	5	
---------	-----------------------	---	---	---	---	--

**Service: S21 DI 7-11 Setup**

Category	Field Name	Value	Low	High	User Value
Service	01 DI07 F=GTC T=Customer	* FALSE			
		PT Reference Select Fast Rate			
Service	02 Mode =				
Service	03 DI07 T=NO F=NC	* FALSE			
		Normally closed switch			
Service	04 Mode =				
Service	05 Use PERM, ALM, SD?	* 5	1	5	
Service	06 DI08 F=GTC T=Customer	* FALSE			
		PT Speed Signal Failed Override			
Service	07 Mode =				
Service	08 DI08 T=NO F=NC	* FALSE			
		Normally closed switch			
Service	09 Mode =				
Service	10 Use PERM, ALM, SD?	* 5	1	5	
Service	11 DI09 F=GTC T=Customer	* FALSE			
		Set PT Reference to Rated			
Service	12 Mode =				
Service	13 DI09 T=NO F=NC	* FALSE			
		Normally closed switch			
Service	14 Mode =				
Service	15 Use PERM, ALM, SD?	* 5	1	5	
Service	16 DI10 F=GTC T=Customer	* FALSE			
		Enable Process Control			
Service	17 Mode =				
Service	18 DI10 T=NO F=NC	* FALSE			
		Normally closed switch			
Service	19 Mode =				
Service	20 Use PERM, ALM, SD?	* 5	1	5	
Service	21 DI11 F=GTC T=Customer	* FALSE			
		Enable Reactive Load Control (VAR/PF)			
Service	22 Mode =				
Service	23 DI11 T=NO F=NC	* FALSE			
		Normally closed switch			
Service	24 Mode =				
Service	25 Use PERM, ALM, SD?	* 5	1	5	

**Service: S22 DI 12-16 Setup**

Category	Field Name	Value	Low	High	User Value
Service	01 DI12 F=GTC T=Customer	* FALSE			
Service	02 Mode =	Enable			

		Remote PT Reference Setpoint			
Service	03 DI12 T=NO F=NC	* FALSE			
Service	04 Mode =	Normally closed switch			
Service	05 Use PERM, ALM, SD?	* 5	1	5	
Service	06 DI13 F=GTC T=Customer	* FALSE			
Service	07 Mode =	Inhibit Synchronizer			
Service	08 DI13 T=NO F=NC	* FALSE			
Service	09 Mode =	Normally closed switch			
Service	10 Use PERM, ALM, SD?	* 5	1	5	
Service	11 DI14 F=GTC T=Customer	* FALSE			
Service	12 Mode =	GEN Breaker Status (52) T=Closed			
Service	13 DI14 T=NO F=NC	* FALSE			
Service	14 Mode =	Normally closed switch			
Service	15 Use PERM, ALM, SD?	* 5	1	5	
Service	16 DI15 F=GTC T=Customer	* FALSE			
Service	17 Mode =	UTILITY Breaker Status T=Open			
Service	18 DI15 T=NO F=NC	* FALSE			
Service	19 Mode =	Normally closed switch			
Service	20 Use PERM, ALM, SD?	* 5	1	5	
Service	21 DI16 F=GTC T=Customer	* FALSE			
Service	22 Mode =	Fuel Sel / Transfer (TRUE=Liq)			
Service	23 DI16 T=NO F=NC	* FALSE			
Service	24 Mode =	Normally closed switch			
Service	25 Use PERM, ALM, SD?	* 5	1	5	

**Service: S23 DI 17-21 Setup**

Category	Field Name	Value	Low	High	User Value
Service	01 DI17 F=GTC T=Customer	* FALSE			
Service	02 Mode =	Lower Voltage (or VAR/PF) Command			
Service	03 DI17 T=NO F=NC	* FALSE			
Service	04 Mode =	Normally closed switch			
Service	05 Use PERM, ALM, SD?	* 5	1	5	



Service	06 DI18 F=GTC T=Customer	* FALSE			
		Raise Voltage (or VAR/PF) Command			
Service	07 Mode =				
Service	08 DI18 T=NO F=NC	* FALSE			
		Normally closed switch			
Service	09 Mode =				
Service	10 Use PERM, ALM, SD?	* 5	1	5	
Service	11 DI19 F=GTC T=Customer	* FALSE			
		Lower Process Control Setpoint			
Service	12 Mode =				
Service	13 DI19 T=NO F=NC	* FALSE			
		Normally closed switch			
Service	14 Mode =				
Service	15 Use PERM, ALM, SD?	* 5	1	5	
Service	16 DI20 F=GTC T=Customer	* FALSE			
		Raise Process Control Setpoint			
Service	17 Mode =				
Service	18 DI20 T=NO F=NC	* FALSE			
		Normally closed switch			
Service	19 Mode =				
Service	20 Use PERM, ALM, SD?	* 5	1	5	
Service	21 DI21 F=GTC T=Customer	* FALSE			
		Flame Detector Input 1			
Service	22 Mode =				
Service	23 DI21 T=NO F=NC	* FALSE			
		Normally closed switch			
Service	24 Mode =				
Service	25 Use PERM, ALM, SD?	* 5	1	5	

**Service: S24 DI 22-24 Setup**

Category	Field Name	Value	Low	High	User Value
Service	01 DI22 F=GTC T=Customer	* FALSE			
		Flame Detector Input 2			
Service	02 Mode =				
Service	03 DI22 T=NO F=NC	* FALSE			
		Normally closed switch			
Service	04 Mode =				
Service	05 Use PERM, ALM, SD?	* 5	1	5	
Service	06 DI23 F=GTC T=Customer	* FALSE			
		Flame Detector Input 3			
Service	07 Mode =				
Service	08 DI23 T=NO F=NC	* FALSE			
		Normally closed			
Service	09 Mode =				

		switch			
Service	10 Use PERM, ALM, SD?	* 5	1	5	
Service	11 DI24 F=GTC T=Customer	* FALSE			
Service	12 Mode =	Flame Detector Input 4			
Service	13 DI24 T=NO F=NC	* FALSE			
Service	14 Mode =	Normally closed switch			
Service	15 Use PERM, ALM, SD?	* 5	1	5	

**Service: S25 DO 3-7 Setup**

Category	Field Name	Value	Low	High	User Value
Service	01 Select DO_03 function	* 10	1	30	
		OPEN BREAKER COMMAND			
Service	02 Mode =	De-energized			
Service	03 DO_03 State =				
Service	04 Select DO_04 function	* 11	1	30	
		CLOSE BREAKER COMMAND			
Service	05 Mode =	De-energized			
Service	06 DO_04 State =				
Service	07 Select DO_05 function	* 25	1	30	
		OPEN GAS FUEL SHUTOFF VALVES			
Service	08 Mode =	De-energized			
Service	09 DO_05 State =				
Service	10 Select DO_06 function	* 26	1	30	
		OPEN LIQUID FUEL SHUTOFF VALVES			
Service	11 Mode =	De-energized			
Service	12 DO_06 State =				
Service	13 Select DO_07 function	* 24	1	30	
		IGNITORS ON			
Service	14 Mode =	De-energized			
Service	15 DO_07 State =				

**Service: S26 DO 8-12 Setup**

Category	Field Name	Value	Low	High	User Value
Service	01 Select DO_08 function	* 23	1	30	
		STARTER ENGAGED			
Service	02 Mode =	De-energized			
Service	03 DO_08 State =				
Service	04 Select DO_09 function	* 9	1	30	
		PT SPEED REF. LOWER			
Service	05 Mode =				

		LIMIT			
Service	06 DO_09 State =	Energized			
Service	07 Select DO_10 function	* 12	1	30	
Service	08 Mode =	RAISE VOLT CMD TO AVR			
Service	09 DO_10 State =	De-energized			
Service	10 Select DO_11 function	* 13	1	30	
Service	11 Mode =	LOWER VOLT CMD TO AVR			
Service	12 DO_11 State =	De-energized			
Service	13 Select DO_12 function	* 14	1	30	
Service	14 Mode =	SPEED IN CONTROL			
Service	15 DO_12 State =	De-energized			

**Service: S27 AO 1-4 Setup**

Category	Field Name	Value	Low	High	User Value
Service	01 Select function for AO01	* 1	1	24	
Service	02 Mode =	PT actual speed readout			
Service	03 Analog Out1 Val at 4 mA	* 0	-20000	20000	
Service	04 Analog Out1 Val at 20 mA	* 5000	-20000	20000	
Service	05 Present AO_01 dmd value	173.81			
Service	06 Select function for AO02	* 1	1	24	
Service	07 Mode =	PT actual speed readout			
Service	08 Analog Out2 Val at 4 mA	* 0	-20000	20000	
Service	09 Analog Out2 Val at 20 mA	* 5000	-20000	20000	
Service	10 Present AO_02 dmd value	173.81			
Service	11 Select function for AO03	* 1	1	24	
Service	12 Mode =	PT actual speed readout			
Service	13 Analog Out3 Val at 4 mA	* 0	-20000	20000	
Service	14 Analog Out3 Val at 20 mA	* 100	-20000	20000	
Service	15 Present AO_03 dmd value	173.81			
Service	16 Select function for AO04	* 1	1	24	
Service	17 Mode =	PT actual speed readout			
Service	18 Analog Out4 Val at 4 mA	* 0	-20000	20000	
Service	19 Analog Out4 Val at 20 mA	* 2000	-20000	20000	
Service	20 Present AO_04 dmd value	173.81			

**Service: S28 AO 5-8 Setup**

Category	Field Name	Value	Low	High	User Value
Service	01 Select function for AO05	* 1	1	24	
Service	02 Mode =	PT actual			

		speed readout			
Service	03 Analog Out5 Val at 4 mA	* 0	-20000	20000	
Service	04 Analog Out5 Val at 20 mA	* 300	-20000	20000	
Service	05 Present AO_05 dmd value	173.87			
Service	06 Select function for AO06	* 1	1	24	
Service	07 Mode =	PT actual speed readout			
Service	08 Analog Out6 Val at 4 mA	* 0	-20000	20000	
Service	09 Analog Out6 Val at 20 mA	* 100	-20000	20000	
Service	10 Present AO_06 dmd value	173.87			
Service	11 Select function for AO07	* 1	1	24	
Service	12 Mode =	PT actual speed readout			
Service	13 Analog Out7 Val at 4 mA	* 0	-20000	20000	
Service	14 Analog Out7 Val at 20 mA	* 11000	-20000	20000	
Service	15 Present AO_07 dmd value	173.87			
Service	16 Select function for AO08	* 1	1	24	
Service	17 Mode =	PT actual speed readout			
Service	18 Analog Out8 Val at 4 mA	* 0	-20000	20000	
Service	19 Analog Out8 Val at 20 mA	* 11000	-20000	20000	
Service	20 Present AO_08 dmd value	173.87			

**Service: S29 AO 9-10 Setup**

Category	Field Name	Value	Low	High	User Value
Service	01 Select function for AO09	* 1	1	24	
Service	02 Mode =	PT actual speed readout			
Service	03 Analog Out9 Val at 4 mA	* 0	-20000	20000	
Service	04 Analog Out9 Val at 20 mA	* 100	-20000	20000	
Service	05 Present AO_09 dmd value	173.86			
Service	06 Select function for AO10	* 1	1	24	
Service	07 Mode =	PT actual speed readout			
Service	08 Analog Out10 Val at 4mA	* 0	-20000	20000	
Service	09 Analog Out10 Val at 20mA	* 100	-20000	20000	
Service	10 Present AO_10 dmd value	173.86			

**Service: S30 PowerSense SETUP**

Category	Field Name	Value	Low	High	User Value
Service	01 GEN Phase A Cur Gain	* 1	0.5	1.5	
Service	02 GEN Phase B Cur Gain	* 1	0.5	1.5	
Service	03 GEN Phase C Cur Gain	* 1	0.5	1.5	
Service	04 GEN Phase A Volt Gain	* 1	0.5	1.5	
Service	05 GEN Phase B Volt Gain	* 1	0.5	1.5	
Service	06 GEN Phase C Volt Gain	* 1	0.5	1.5	
Service	07 GEN PT Avg Volts	0			

Service	08 Voltage Units				
Service	09 GEN CT Avg Amps	0			
Service	10 Current Units				
Service	11 Mains Phase A Cur Gain	* 1	0.5	1.5	
Service	12 Mains Phase B Cur Gain	* 1	0.5	1.5	
Service	13 Mains Phase C Cur Gain	* 1	0.5	1.5	
Service	14 Mains Phase A Volt Gain	* 1	0.5	1.5	
Service	15 Mains Phase B Volt Gain	* 1	0.5	1.5	
Service	16 Mains Phase C Volt Gain	* 1	0.5	1.5	
Service	17 BUS PT Avg Volts	0			
Service	18 Voltage Units				
Service	19 BUS CT Avg Amps	0			
Service	20 Current Units				

**Service: S31 RELAY OUTPUT FORCING**

Category	Field Name	Value	Low	High	User Value
Service	01 OK to Enter Cal Mode?	TRUE			
Service	02 Enable Calibration Mode	* FALSE			
Service	03 Relay Out 01 Dmd State	* FALSE			
Service	04 Relay Out 02 Dmd State	* FALSE			
Service	05 Relay Out 03 Dmd State	* FALSE			
Service	06 Relay Out 04 Dmd State	* FALSE			
Service	07 Relay Out 05 Dmd State	* FALSE			
Service	08 Relay Out 06 Dmd State	* FALSE			
Service	09 Relay Out 07 Dmd State	* FALSE			
Service	10 Relay Out 08 Dmd State	* FALSE			
Service	11 Relay Out 09 Dmd State	* FALSE			
Service	12 Relay Out 10 Dmd State	* FALSE			
Service	13 Relay Out 11 Dmd State	* FALSE			
Service	14 Relay Out 12 Dmd State	* FALSE			

**Service: S32 ANALOG OUTPUT FORCING**

Category	Field Name	Value	Low	High	User Value
Service	01 Analog Out 01 Demand Val	* 0	-20000	20000	
Service	02 Analog Out 01 Offset	* 0	-1000	1000	
Service	03 Analog Out 01 Gain	* 1	0	2	
Service	04 Analog Out 02 Demand Val	* 0	-20000	20000	
Service	05 Analog Out 02 Offset	* 0	-1000	1000	
Service	06 Analog Out 02 Gain	* 1	0	2	
Service	07 Analog Out 03 Demand Val	* 0	-20000	20000	
Service	08 Analog Out 03 Offset	* 0	-487500	487500	
Service	09 Analog Out 03 Gain	* 1	0	2	
Service	10 Analog Out 04 Demand Val	* 0	-20000	20000	
Service	11 Analog Out 04 Offset	* 0	-487500	487500	
Service	12 Analog Out 04 Gain	* 1	0	2	
Service	13 Analog Out 05 Demand Val	* 0	-20000	20000	
Service	14 Analog Out 05 Offset	* 0	-487500	487500	
Service	15 Analog Out 05 Gain	* 1	0	2	
Service	16 Analog Out 06 Demand Val	* 0	-20000	20000	

Service	17 Analog Out 06 Offset	*	0	-1000	1000	
Service	18 Analog Out 06 Gain	*	1	0	2	
Service	19 Analog Out 06 Demand Val		0			
Service	20 Voltage Bias Out Offset	*	0	-50	50	
Service	21 Voltage Bias Out Gain	*	1	0.2	1.5	

**Service: S33 ANALOG OUTPUT FORCING**

Category	Field Name		Value	Low	High	User Value
Service	01 Analog Out 06 Demand Val	*	0	-20000	20000	
Service	02 Analog Out 06 Offset	*	0	-1000	1000	
Service	03 Analog Out 06 Gain	*	1	0	2	
Service	04 Analog Out 07 Demand Val	*	0	-20000	20000	
Service	05 Analog Out 07 Offset	*	0	-487500	487500	
Service	06 Analog Out 07 Gain	*	1	0	2	
Service	07 Analog Out 08 Demand Val	*	0	-20000	20000	
Service	08 Analog Out 08 Offset	*	0	-487500	487500	
Service	09 Analog Out 08 Gain	*	1	0	2	
Service	10 Analog Out 09 Demand Val	*	0	-20000	20000	
Service	11 Analog Out 09 Offset	*	0	-487500	487500	
Service	12 Analog Out 09 Gain	*	1	0	2	
Service	13 Analog Out 10 Demand Val	*	0	-20000	20000	
Service	14 Analog Out 10 Offset	*	0	-487500	487500	
Service	15 Analog Out 10 Gain	*	1	0	2	
Service	16 Analog Out 06 Demand Val		0			
Service	17 Voltage Bias Out Offset	*	0	-50	50	
Service	18 Voltage Bias Out Gain	*	1	0.2	1.5	

**Service: S34 VALVE CALIB & STROKE**

Category	Field Name		Value	Low	High	User Value
Service	01 OK to Enter Cal Mode?		TRUE			
Service	02 Enable Calibration Mode	*	FALSE			
Service	03 Gas Fuel Metr VLV Stroke	*	0	0	100	
Service	04 Gas Fuel Act 1 Output		0			
Service	05 Act1 Type 0-20 / 0-200mA	*	0	0	1	
Service	06 Act1 Type Chosen		Current Output 0-20 mA			
Service	07 Act1 mA at 0% Dmnd	*	4	-200	200	
Service	08 Readback of Min mA value		4			
Service	09 Act1 mA at 100% Dmnd	*	20	-200	200	
Service	10 Readback of Max mA value		20			
Service	11 Act1 Offset	*	0	-200	200	
Service	12 Act1 Gain	*	1	0	2	
Service	13 Act1 Dither	*	0	0	3	
Service	14 Liq Fuel Metr VLV Stroke	*	0	0	100	
Service	15 Liquid Fuel Act 2 Output		0			
Service	16 Act2 Type 0-20 / 0-200mA	*	0	0	1	
Service	17 Act2 Type Chosen		Current Output 0-20 mA			

Service	18 Act2 mA at 0% Dmnd	*	4	-200	200	
Service	19 Readback of Min mA value		4			
Service	20 Act2 mA at 100% Dmnd	*	20	-200	200	
Service	21 Readback of Max mA value		20			
Service	22 Act2 Offset	*	0	-200	200	
Service	23 Act2 Gain	*	1	0	2	
Service	24 Act2 Dither	*	0	0	3	
Service	25 Initiate Fuel XFER T=Liq	*	FALSE			

**Service: S35 START / LITEOFF SETUP**

Category	Field Name		Value	Low	High	User Value
Service	01 Use Electric Liteoff?	*	TRUE			
Service	02 Start Ramp Rate	*	0.3	0.1	100	
Service	03 Start Ramp Gas Min Fuel	*	0	0	100	
Service	04 Start Ramp Liq Min Fuel	*	0	0	100	
Service	05 Manual Crank/Starter ON	*	FALSE			
Service	06 Hold after Lite-off	*	FALSE			
Service	07 Manual Crank Time Limit	*	30	0.1	120	

**Service: S36 START/STOP SEQUENCE**

Category	Field Name		Value	Low	High	User Value
Service	01 Use Auto Start/Stop SEQ?	*	TRUE			
Service	02 Use Fuel SOV/IGN Output?	*	TRUE			
Service	03 Min Starter Crank Speed	*	1000	100	2000	
Service	04 Time to wait for Speed	*	20	0	120	
Service	05 Purge Timer/Crank Time?	*	30	0	3000	
Service	06 Wait for Liteoff Tmr Gas	*	10	2	30	
Service	07 Wait for Liteoff Tmr Liq	*	15	2	30	
Service	08 Starter Cutout Speed	*	2000	100	5000	
Service	09 Max Time to Idle Speed	*	120	5	600	
Service	10 Warm-up Time at Idle	*	30	2	600	
Service	11 Raise Ref at FastRate?	*	TRUE			
Service	12 Fast Rate to Rated Spd	*	50	2	1000	
Service	13 Max Time to Rated Spd	*	60	5	600	
Service	14 Cooldown Time/Idle	*	10	0	1800	

**Service: S37 REMOTE SPEED REF SETUP**

Category	Field Name		Value	Low	High	User Value
Service	01 Using Rem Ref Signl?		TRUE			
Service	02 Remote Ref Low Limit		3600			
Service	03 Remote Ref High Limit		3780			
Service	04 Remote Ref Lrg Error Rat	*	4	0	100	
Service	05 Remote Ref Small Window	*	1	0	100	
Service	06 Remote Ref Large Window	*	5	0	100	

**Service: S38 SPEED CONTROL SETUP**

Category	Field Name		Value	Low	High	User Value
Service	01 Spd Prop Gain 1	*	0.5	0	100	

Service	02 Spd Integral Gain 1	*	0.8	0	50	
Service	03 Spd SDR 1	*	0.2	0.01	100	
Service	04 Use Dual Dynamics	*	TRUE			
Service	05 Spd Prop Gain 2	*	0.15	0	100	
Service	06 Spd Integral Gain 2	*	0.5	0	50	
Service	07 Spd SDR 2	*	0.2	0.01	100	
Service	08 Spd Low Limit		3000			
Service	09 Spd High Limit		3780			
Service	10 Spd Reference Default Rate	*	2	0	1000	
Service	11 Spd Reference Fast Rate	*	4	0	1000	
Service	12 Use Spd Auto Override	*	TRUE			
Service	13 Time to wait for Speed		20			
Service	14 Speed Switch 1	*	1500	0	100000	
Service	15 Speed Switch 2	*	3500	0	100000	
Service	16 Speed Switch 3	*	3600	0	100000	
Service	17 Overspeed Test Enable	*	FALSE			
Service	18 OVRSPD bias (+/-100)	*	10	5	100	
Service	19 Speed Value		100			
Service	20 Speed Setpoint		3000			
Service	21 Spd Control PID Output		101			
Service	22 Raise Spd Reference	*	FALSE			
Service	23 Lower Spd Reference	*	FALSE			

**Service: S39 EGT CONTROL SETUP**

Category	Field Name		Value	Low	High	User Value
Service	01 EGT Contrl Base Setpoint		0			
Service	02 EGT PID Proportional Gn	*	0.3	0.001	100	
Service	03 EGT PID Integral Gain	*	0.8	0	50	
Service	04 EGT PID SDR term	*	100	0.01	100	
Service	05 Use Temp Start Ramp	*	FALSE			
Service	06 Temp Ramp Lo Temp	*	600	0	10000	
Service	07 Temp Ramp Hi Temp	*	900	0	10000	
Service	08 Temp Ramp Rise Rate	*	10	0	100	
Service	09 EGT Average Temp		-1.77			
Service	10 EGT Control PID Output		0.54			
Service	11 EGT Deriv Setpoint rate	*	5	0	50	

**Service: S40 REAL LOAD CONTROL SETUP**

Category	Field Name		Value	Low	High	User Value
Service	01 Confirm MW Sensr Range		80			
Service	02 Droop Percent	*	5	0	8	
Service	03 Min Load mW Setpoint	*	2	0.5	20	
Service	04 Base Load mW Setpoint	*	50	1	200	
Service	05 Using Remote MW Setpoi		FALSE			
Service	06 Auto Loading Rate (sec	*	60	1	7200	
Service	07 Normal Unload Rate	*	60	1	7200	
Service	08 Low Load / Open Brkr L		2			
Service	09 Low Load Alarm Level	*	5	0	30000	
Service	10 High Load Alarm Level	*	300	0	30000	



Service	11 Use Load Limiter (=2)	*	FALSE			
Service	12 Load PID Prop Gain	*	1.25	0.001	100	
Service	13 Load PID Integral Gain	*	2.2	0	50	
Service	14 Load PID Output Value		101			
Service	15 Enable LS Functions		FALSE			
Service	16 Utility Breaker Open?		FALSE			
Service	17 XFER Rate IN/OUT of LS	*	10	0.1	60	
Service	18 Number of Network Node		0			
Service	19 Number of Nodes in LS		0			

**Service: S41 SYNCHRONIZER**

Category	Field Name		Value	Low	High	User Value
Service	01 SYNC MODE	*	4	1	4	
Service	02 SYNC MODE		RUN/AUTO			
Service	03 SYNC GAIN	*	0.15	0.001	100	
Service	04 SYNC INTEGRAL	*	0.56	0.01	100	
Service	05 VOLTAGE RAMP TIME	*	300	1	600	
Service	06 SYNCROSCOPE		180			
Service	07 VOLTAGE MATCHING	*	TRUE			
Service	08 VOLTAGE MATCHING		ENABLED			
Service	09 VOLTAGE WINDOW	*	1	0.1	10	
Service	10 SYNC TYPE	*	TRUE			
Service	11 SYNC TYPE		PHASE CONTROL			
Service	12 PHASE WINDOW	*	10	2	20	
Service	13 SLIP WINDOW	*	0.1	-0.3	0.3	
Service	14 SLIP FREQUENCY	*	0.1	-0.3	0.3	
Service	15 CLOSE ATTEMPTS	*	3	0	20	
Service	16 RECLOSE DELAY	*	5	1	1200	
Service	17 AUTO RESYNCHRONIZE	*	TRUE			
Service	18 AUTO RESYNCHRONIZE		ENABLED			
Service	19 CIRCUIT BREAKER TYPE	*	TRUE			
Service	20 CIRCUIT BREAKER TYPE		BREAKER			
Service	21 SYNCH TIMEOUT	*	0	0	1200	
Service	22 DEADBUS CLOSURE	*	TRUE			
Service	23 DEADBUS CLOSURE		ENABLED			
Service	24 BREAKER HOLD TIME	*	1	0	10	
Service	25 BKR CLOSE DLY TIME	*	0.1	0.01	2	
Service	26 ENABLE SYNC TEST	*	FALSE			
Service	27 ENABLE SYNC TEST		DISABLED			
Service	28 SLIP WITHIN LIMITS		FALSE			
Service	29 PHASE WITHIN LIMITS		FALSE			
Service	30 VOLTAGE WITHIN LIMITS		FALSE			
Service	31 RECLOSE ATTEMPTS		0			
Service	32 SYNC TIMEOUT REMAINING		0			
Service	33 SYNC STATE		DISABLED			
Service	34 SYNC MODE		DISABLED			
Service	35 GEN STABILIZE TIME DELAY	*	30	1	30000	

**Service: S42 REACTIVE LOAD CONTROL**

Category	Field Name	Value	Low	High	User Value
Service	01 Select VAR/PF Mode	* 0	0	2	
Service	02 Mode Selected	Disabled			
Service	03 VARPF GAIN	* 0.2	0.01	20	
Service	04 VOLTAGE RAMP TIME	* 20	0	1000	
Service	05 PF SHARE GAIN	* 0.2	0.001	20	
Service	06 VARPF INTEGRAL GN	* 0.1	0	20	
Service	07 VAR/PF PID Output	0			
Service	08 INITIAL VAR REFERENCE	* 10	-30000	30000	
Service	09 VAR REFERENCE	0			
Service	10 GEN TOTAL VAR	0			
Service	11 INITIAL PF REFERENCE	* 0	-0.5	0.5	
Service	12 PF REFERENCE	1			
Service	13 PF REF DIRECTION	Lag			
Service	14 PF DEADBAND	* 0.03	0	1	
Service	15 GEN AVERAGE PF	1			
Service	16 PF ACTUAL DIRECTION	Lag			
Service	17 OPERATING VOLTAGE	* 480	0.001	30000	
Service	18 IS VAR/PF CNTRL ENABLED	FALSE			
Service	19 VAR/PF CNTRL STATUS	VAR/PF Disabled			
Service	22 VOLTAGE BIAS OUTPUT	0			
Service	23 KVA Switch Hi Level	* 30	0	30000	
Service	24 KVA Switch Lo Level	* 5	0	30000	
Service	25 Use Voltage Trim?	* FALSE			

**Service: S43 PROCESS CONTROL**

Category	Field Name	Value	Low	High	User Value
Service	01 PROCESS GAIN	* 0.05	0.001	20	
Service	02 PROCESS INTEGRAL GN	* 0.3	0	20	
Service	03 PROCESS DERIVATIVE	* 100	0.01	100	
Service	04 PROCESS PID OUTPUT	100			
Service	05 PROCESS DEADBAND	* 0	-30000	30000	
Service	06 PROCESS DROOP	* 0	0	50	
Service	07 PROCESS FILTER	* 1	0.01	10	
Service	08 PROCESS SETPOINT	* 0	-30000	30000	
Service	09 ENABLE REM ANALOG SET	* FALSE			
Service	10 PROCESS REF VALUE	-0.04			
Service	11 PROCESS INPUT VALUE	-0.04			
Service	12 PROCESS PERMS MET?	FALSE			
Service	13 PROCESS CNTRL ON?	FALSE			
Service	14 ENABLE DISCRET INS	* FALSE			
Service	15 Direct Proc (F=Indirect)	* TRUE			
Service	16 Process Load Rate	* 0.2	0	10	
Service	17 Process Unload Rate	* 0.2	0	10	
Service	18 This Unit is Proc Master	TRUE			

**Service: S44 GENERATOR PROTECTION 1**

Category	Field Name	Value	Low	High	User Value
----------	------------	-------	-----	------	------------

Service	01 GEN Over Volt Alm Level	*	700	0	30000	
Service	02 GEN Under Volt Alm Leve	*	300	0	30000	
Service	03 GEN Over/Under Vlt Dela	*	10	0.1	120	
Service	04 GEN Phas OverCur AlmLv	*	1500	0	3000	
Service	05 GENPhas OverCur CurvShf	*	1	0.01	10	
Service	06 GEN Over Freq Alm Level	*	70	40	70	
Service	07 GEN Under Freq Alm Leve	*	40	40	70	
Service	08 GEN Over/Undr Freq Dela	*	10	0.1	120	
Service	09 GEN Over Power Alm Leve	*	11000	-30000	30000	
Service	10 GEN Reverse Powr Alm Lv	*	-50	-30000	30000	
Service	11 GEN Direct Pwr Curv Shf	*	1	0.01	10	
Service	12 GEN Over VAR Alm Level	*	1500	-30000	30000	
Service	13 GEN Reverse VAR Alm Lvl	*	-50	-30000	30000	
Service	14 GEN Direct VAR Alm Dela	*	10	0.1	120	
Service	15 GEN NegPhzSeq OvrVlt Lv	*	150	0	30000	
Service	16 GEN NegPhzSeq OvrVlt DI	*	10	0.1	120	
Service	17 GEN NegPhzSeq OvrCur Lv	*	150	0	30000	
Service	18 GEN NegPhzSeq OvrCur DI	*	10	0.1	120	
Service	19 GEN PhasCur Diff Alm Lv	*	150	0	30000	
Service	20 GEN PhasCurDiff CurvShf	*	1	0.01	10	

**Service: S45 GENERATOR PROTECTION 2**

Category	Field Name		Value	Low	High	User Value
Service	01 GEN Over Volt Warn Leve	*	700	0	30000	
Service	02 GEN Under Volt Warn Lev	*	300	0	30000	
Service	03 GEN Over/Under Vlt Dela	*	10	0.1	120	
Service	04 GEN Phas OverCur WarnLv	*	1500	0	3000	
Service	05 GEN Over Freq Warn Leve	*	70	40	70	
Service	06 GEN Under Freq Warn Lev	*	40	40	70	
Service	07 GEN Over/Undr Freq Dela	*	10	0.1	120	
Service	08 GEN Over Power Warn Lev	*	11000	-30000	30000	
Service	09 GEN Revers Powr Warn Lv	*	-50	-30000	30000	
Service	10 GEN Over VAR Warn Level	*	1500	-30000	30000	
Service	11 GEN Reverse VAR Warn Lv	*	-50	-30000	30000	
Service	12 GEN Direct VAR Warn Del	*	10	0.1	120	
Service	13 GEN NegPhzSeq OvrVlt Lv	*	150	0	30000	
Service	14 GEN NegPhzSeq OvrVlt DI	*	10	0.1	120	
Service	15 GEN NegPhzSeq OvrCur Lv	*	150	0	30000	
Service	16 GEN NegPhzSeq OvrCur DI	*	10	0.1	120	
Service	17 GEN PhasCur Dif Warn Lv	*	150	0	30000	

## Appendix E.

# Pre-Installation Control Information Checklist

---

### Detail an I/O list (interfaces to GTC Fuel Control)

- Analog Inputs & Outputs – (ranges, units, alarm & shutdown points)
- Discrete Inputs – Active high or low
- Relay outputs – NO or NC, contact load ratings
- MPU Speed sensor specifications (# of teeth, gear ratio, hi/lo fail speeds)
- PowerSense module info PT/CT ratios, rated voltage, frequency
- Fuel Actuator/Valve drivers – mA range (need SPC?), PPH flow vs. Valve Pos.
- Operator Interface – size, location, desired functionality
- Communication Links to other devices – signal type, protocols
- Termination wiring details (existing & upgrades)

### Control Limits

- EGT topping temperature limit
- EGT Derivative Limit (degrees F / sec)
- Speed – upper limit (Alm & SD), Ref limits (high & low)
- Any Required Acceleration or Deceleration Schedules
- Load Control functions utilized (or desired in the upgrade)

### Start-up Information

- Electrical or Mechanical lite-off, valve degrees, start ramp percent
- Fuel Info – Type, supply pressure, LHV, SG, fuel flow information
- Manifold pressure at lite-off
- Any EGT Start overtemp limit
- Time from Lite-off to Idle Speed
- Time from Idle to Rated speed

### Running Information

- How do they typically operate the unit (Peak, Baseload, Process...)
- Gathering the following info will greatly simplify GTC control configuration

Data Point	CDP (psia) or Load (mw)	EGT (deg F)	PT Speed Ref.	Fuel Valve (%)	Fuel Flow
@ Idle Speed					
@ Rated speed					
@ 10% Load					
@ 25% Load					
@ 50% Load					
@ 75% Load					
@ 100% Load					

## Appendix F.

# Interfacing to Distributed IO and Multiprog

### Adding Multiprog programming into the GTC190–

The system documentation CD contains the source code of the Master GAP file (or sometimes called the Second-ring file). The programmer should have a good working knowledge of GAP programming and the use of the GAP editor tool, including a clear understanding of what the meaning of terms template and coder versions. In most cases the GTC190 GAP file will be used as a reference in finding the software 'handles' (both input & output) of the control signals and also the tunable fields that have been programmed as being available to the Multiprog programming environment. Input fields that are available for MP control are identified with a boxed mp designation. The programmer can pass any GAP block output field to Multiprog for use in programming.

Additional programming help can be found in the GAP help file that will assist the programmer in interfacing the 2 programs together.

The MP category contains GAP blocks that are created for use by MultiProg.

The programmer should refer to KW Software – Multiprog IEC 611-31-3 programming tool for more information on programming structure and methodology.

### Allen-Bradley Flex IO–

The GTC190 includes a third GAP file (p/n 5418-2415) that contains all of the GAP blocks that are required to interface to a defined set of Allen-Bradley Flex I/O Modules (1794-series). The user can use the program to access all inputs and outputs as well as fault flags for the individual modules and channels.

The Allen-Bradley Flex IO design utilizes a PROFIBUS communication head that has up to 8 IO module blocks programmed after it. In the GTC implementation 4 heads are used designated as Slave 1 through Slave 4. The GTC190 comes with an installation CD of the Applicom I/O configuration tool (Version 2.1 – Service Pack 2). After installing this the user will need to go to the Woodward website and download and install the service pack version 3 for this tool. Once this is done the user will need to construct a setup file to match his actual hardware. It is important that the layout match the one shown in the control wiring appendix of this manual. Either the AB Profibus or ProSoft communication heads can be used, however they do require different Applicom configuration files. The DeviceNet equipment must also be defined in this file. An example applicom file is supplied on the CD and can be used as a guide in adding this information to the specific Applicom file configuration for the system. Once the file setup is complete it must be 'compiled' by the applicom tool to create an *applicom.ply* file. This file must be placed on the AtlasPC with the application to allow the GAP to interface to the distributed I/O.

**IMPORTANT**

Refer to Appendix A for I/O Module Layout. It is critical to follow this layout exactly so that the GAP logic can correctly decode the information from the addresses sent from the communication heads. It is possible to leave out the last nodes in the equipment groups 1 & 2. In groups 3 & 4 it is not acceptable to leave out nodes between the first and last, unless you are not using any RTDs or AO modules. For example – if any RTD nodes are needed, then all 6 T/C nodes must be present.



We appreciate your comments about the content of our publications.

Send comments to: [icinfo@woodward.com](mailto:icinfo@woodward.com)

Please reference publication **26302**.



PO Box 1519, Fort Collins CO 80522-1519, USA  
1000 East Drake Road, Fort Collins CO 80525, USA  
Phone +1 (970) 482-5811 • Fax +1 (970) 498-3058

Email and Website—[www.woodward.com](http://www.woodward.com)

Woodward has company-owned plants, subsidiaries, and branches,  
as well as authorized distributors and other authorized service and sales facilities throughout the world.

Complete address / phone / fax / email information for all locations is available on our website.