



Installation Manual

8924-826 Installation Kit

**for EPG 1712/1724 Electric Actuator
on the Caterpillar 3114T and 3116T Engines**

Manual 54115

IMPORTANT



This is the safety alert symbol. It is used to alert you to potential personal injury hazards. Obey all safety messages that follow this symbol to avoid possible injury or death.

DEFINITIONS

- **DANGER**—Indicates a hazardous situation which, if not avoided, will result in death or serious injury.
- **WARNING**—Indicates a hazardous situation which, if not avoided, could result in death or serious injury.
- **CAUTION**—Indicates a hazardous situation which, if not avoided, could result in minor or moderate injury.
- **NOTICE**—Indicates a hazard that could result in property damage only (including damage to the control).
- **IMPORTANT**—Designates an operating tip or maintenance suggestion.

WARNING

The engine, turbine, or other type of prime mover should be equipped with an overspeed shutdown device to protect against runaway or damage to the prime mover with possible personal injury, loss of life, or property damage.

The overspeed shutdown device must be totally independent of the prime mover control system. An overtemperature or overpressure shutdown device may also be needed for safety, as appropriate.



Read this entire manual and all other publications pertaining to the work to be performed before installing, operating, or servicing this equipment. Practice all plant and safety instructions and precautions. Failure to follow instructions can cause personal injury and/or property damage.



This publication may have been revised or updated since this copy was produced. To verify that you have the latest revision, be sure to check the Woodward website:

www.woodward.com/pubs/current.pdf

The revision level is shown at the bottom of the front cover after the publication number. The latest version of most publications is available at:

www.woodward.com/publications

If your publication is not there, please contact your customer service representative to get the latest copy.



Any unauthorized modifications to or use of this equipment outside its specified mechanical, electrical, or other operating limits may cause personal injury and/or property damage, including damage to the equipment. Any such unauthorized modifications: (i) constitute "misuse" and/or "negligence" within the meaning of the product warranty thereby excluding warranty coverage for any resulting damage, and (ii) invalidate product certifications or listings.

NOTICE

To prevent damage to a control system that uses an alternator or battery-charging device, make sure the charging device is turned off before disconnecting the battery from the system.

NOTICE

To prevent damage to electronic components caused by improper handling, read and observe the precautions in Woodward manual 82715, *Guide for Handling and Protection of Electronic Controls, Printed Circuit Boards, and Modules*.

8924-826 Installation Kit for EPG 1712/1724 on the Caterpillar 3114T and 3116T Engines

Introduction

These instructions apply to the EPG model 1712/1724 (12 or 24 V) electric actuator manufactured by Woodward as mounted on a Caterpillar 3114T or 3116T Engine, driving a generator set.

The mounting kit is Woodward part number 8924-826. The kit does not include the wiring harness or the magnetic pickup utilized by the electronic control system. The mounting kit does not include the actuator.

The actuator, when mounted on the diesel engine, operates the speed-setting lever on the Caterpillar governor. The mounting kit was designed for engines with a turbocharger and water cooling system. The engines are rated for 2000 to 2800 rpm.

Actuator Mounting

1. Refer to Figure 1 to determine the location of the mounting bracket. The short bent side of the bracket goes over the casting, with the welded portion of the bracket toward the back of the engine and facing up. The two large holes in the bracket will attach to the engine block with 10 mm bolts. Do not attach the bracket at this time. The new linkage to the speed-setting lever should be attached first because the new bracket will make access difficult (see Figure 2).

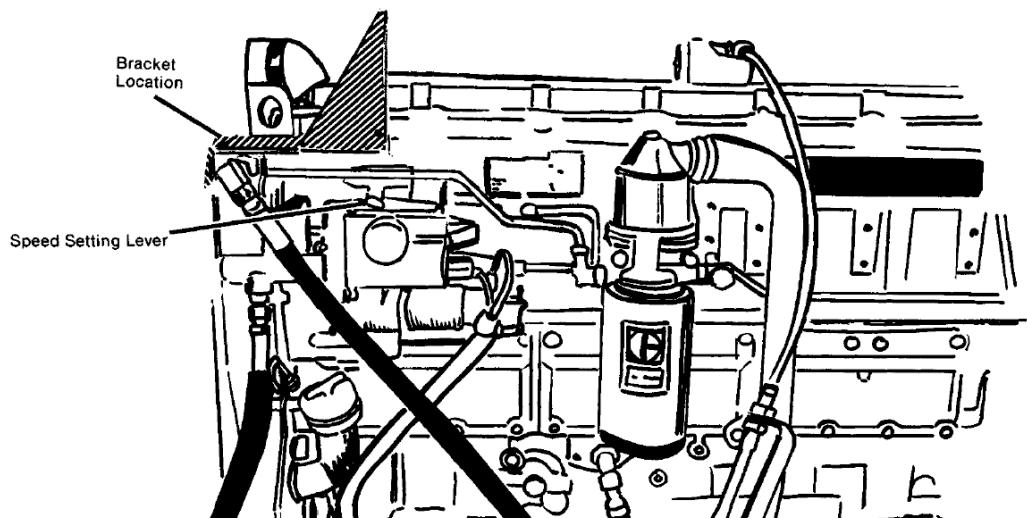

Figure 1. Actuator Bracket Mounted on Caterpillar 3114 or 3116 Diesel Engine

2. Remove any existing linkage from the speed-setting lever on the engine governor in preparation for the attachment of the new linkage to the lever. If necessary adjust the lever position so it is vertical to the side of the engine at mid-stroke.

3. Assemble the locknuts and rod ends on the 0.250-28 x 3.750 inch threaded rod. Thread one of the rod ends on between 5 and 9 full turns. Tighten the locknut on this rod end. Do not tighten the other locknut at this time. The rod does not work as a turnbuckle and it is necessary to turn a rod end for final adjustment of the length.
4. Attach the rod end with the tightened locknut to the engine governor's speed-setting lever with a 0.250-28 screw through a high-collar lock washer, then through the rod end, a second lock washer and through the hole in the speed-setting lever. Torque a 0.250-28 elastic locknut to 80 lb-in (9.0 N·m) (Figure 2). (If more convenient, the 0.250-28 screw may come up through the speed-setting lever, with lock washers on both sides of the rod end.)

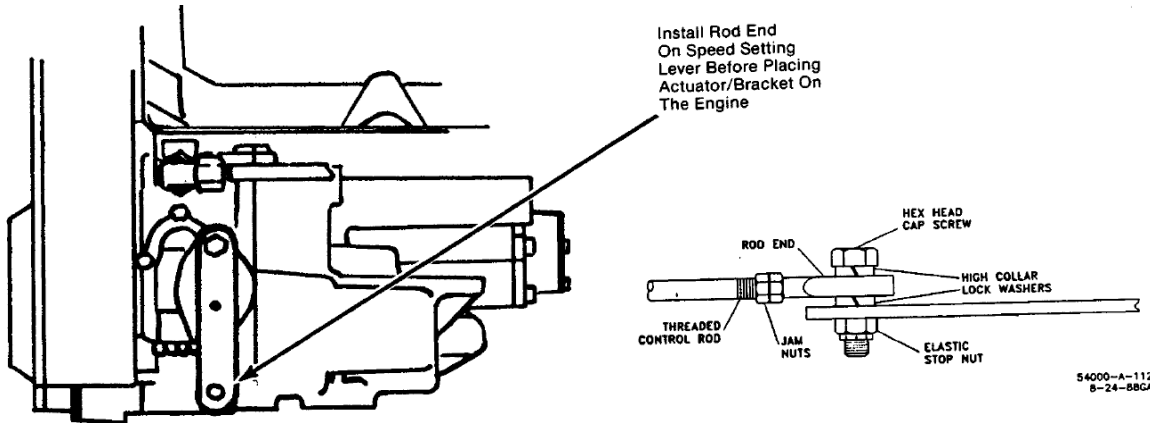

Figure 2. Rod End to Speed Setting Lever

5. Place the actuator on the mounting bracket with the electrical connector facing away from the bent lip which will attach to the engine block. The counterclockwise terminal shaft will be used. Attach this end to the round holes in the bracket. Attach the clockwise terminal shaft end of the actuator to the two slots.
6. Attach the actuator to the mounting bracket with four 0.250-20 x .500 inch hex-head screws, flat washers, and split lock washers supplied with the kit. The screws go through the split-lock washer, then the flat washer, then the bracket and into the actuator. No gasket or washer is used between the actuator and the bracket surface. Torque the screws to 80 to 100 lb-in (9.0 to 11.3 N·m).
7. Attach the brace to the actuator as shown. Use a 0.250- 20 screw, flat washer, and lock washer through the slot in the brace and tighten to 80 to 100 lb-in (9.0 to 11.3 N·m).
8. Attach the actuator and bracket to the engine with two 10 mm hex-head screws and washers.

The fuel return line and the manual speed-setting cable are both supported on bolts in the same holes used for the mounting bracket. Remove the support bolts, move the return line support to the opposite side (if necessary) and attach the electric actuator bracket with a long bolt removed from the return-line support and with a short 10 mm bolt supplied with the kit. Attach the fuel return line with the other short 10 mm bolt in the same hole used to attach the actuator and bracket, but from the other side. Torque all 10 mm bolts to 600 to 650 lb-in (68 to 73 N·m).

9. Refer to Figure 3 and attach the mounting-kit brace from the actuator to the generator engine. An 8 mm screw is used through the round hole of the brace to attach to the engine head. The bends in the brace may require adjustment for some installations.

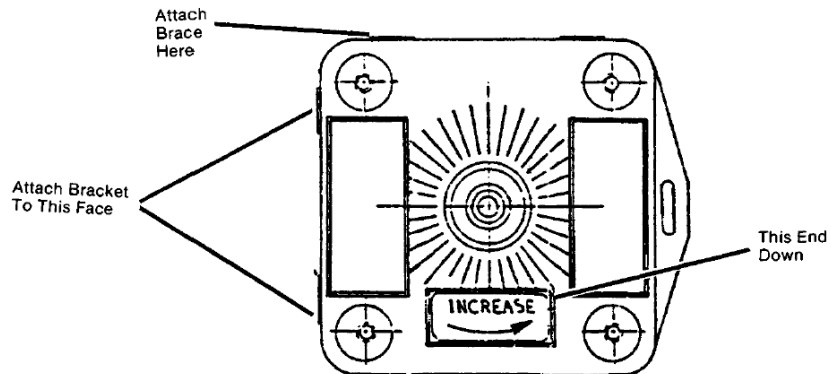

Figure 3. Actuator Face Showing Bracket and Brace Installation

10. Attach the actuator lever supplied with the kit to one of the rod ends. The long side of the actuator lever goes toward the rod end. The short side of the lever will go toward the actuator. To attach the rod end to the lever, place a 0.250-28 x 1 inch screw through the second hole from the end of the actuator lever. Add a high-collar split lock washer, the rod end, another split lock washer, and an elastic locknut. Torque to 80 lb-in (9.0 N·m).
11. Attach the actuator lever to the actuator shaft (see Figure 4). The actuator will be at the minimum-fuel position, and the actuator lever should be at about a right angle to the side of the engine.

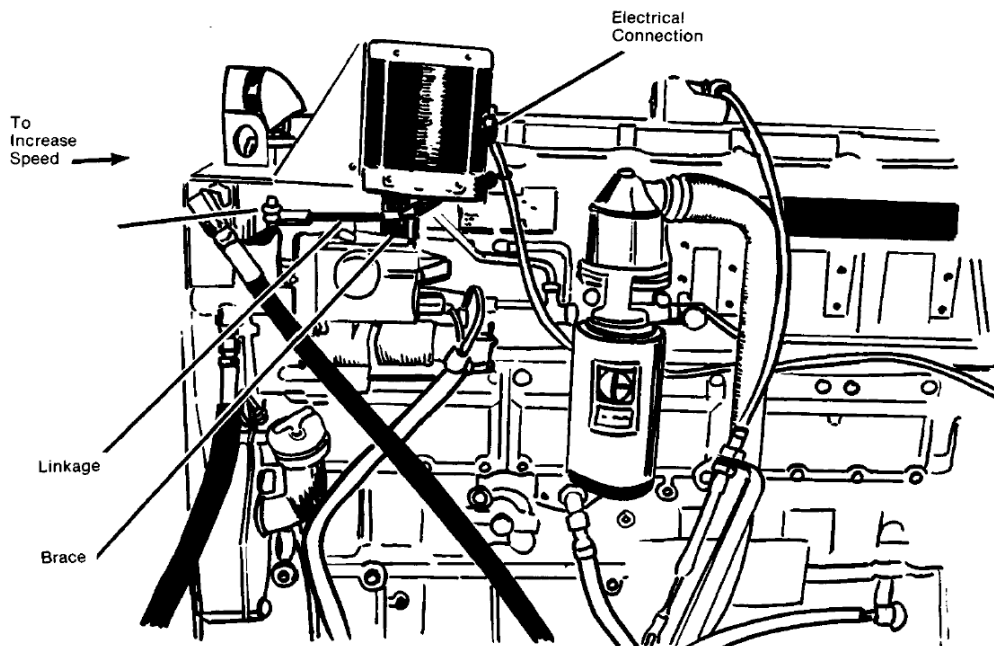

Figure 4. Actuator Installed, Showing Brace, and Electrical Connection Location

12. Use the 0.250-28 x 1 inch screw, two flat washers and a 0.250-28 elastic locknut to attach the lever to the actuator shaft. Torque to 73 to 87 lb-in (8.2 to 9.8 N·m).
13. With the speed-setting lever at a position which will provide about 58 Hz speed at full load (48.5 Hz on 50 Hz sets), set the length of the threaded rod to attach the rod end to the end hole in the speed-setting lever.

IMPORTANT

When the length of the threaded rod is properly adjusted, the speed setting lever will provide the maximum-fuel stop and the actuator lever will provide the minimum-fuel stop. The actuator lever should move a minimum of 25 degrees between minimum and maximum fuel (30 degrees will provide better stability). Minimum fuel should provide 58 Hz at full load and maximum fuel should provide 64 Hz at full load. (48.5 and 53 Hz on 50 Hz systems).

Response can be delayed if too little shaft movement is used, as this creates a deadband in the electronic control between electrical signal and actual rotation of the actuator shaft. If less than optimal rotation of the actuator shaft must be used, locate the lever so the shaft approaches maximum-fuel stop on maximum-fuel signal.

! WARNING

The engine, turbine, or other type of prime mover should be equipped with an overspeed shutdown device to protect against runaway or damage to the prime mover with possible personal injury, loss of life, or property damage.

The overspeed shutdown device must be totally independent of the prime mover control system. An overtemperature or overpressure shutdown device may also be needed for safety, as appropriate.

14. Tighten the jam nut on the threaded-rod and rod-end assembly when the minimum-maximum fuel-stop and actuator-shaft-movement requirements have been satisfied.

Wiring Suggestions

Use a minimum of 14 AWG (2.0 mm²), stranded, insulated wire from the battery to the control box to the actuator. Using 14 AWG (2.0 mm²) wire, the 12 V actuator will operate with a maximum of 10 ft (3 m) between the control box and the actuator. The total distance in the wiring circuit from the battery to the control box to the actuator must not exceed 40 ft (12 m).

Using 12 AWG (3.0 mm²) wire in the circuit for the 12 V actuator allows these maximum distances to be 35 ft (11 m) from the control box to the actuator and a total of 140 ft (43 m) in the circuit.

The 24-volt actuator will allow the maximum distances to be 35 ft (11 m) between the control box and the actuator for 14 AWG (2.0 mm²) wire and a total of 140 ft (43 m) in the system. Using 12 AWG (3.0 mm²) wire with the 24 V actuator will permit 70 ft (21 m) between the control box and the actuator and 280 ft (85 m) in the circuit.

The wire used must not be kinked, and ties should be of a non-conducting material. Use only new, well insulated, stranded wire in the installation. The wire is not supplied in the mounting kit, but special harnesses are available from Woodward.

Wiring Terminal Fittings

Attach AMP 52941 or AMP 52961 crimp-on number 6, slotted, insulated terminals or equivalent on the control-box end of 12 AWG (3.0 mm²) wires from the actuator and the battery. If 14 AWG (2.0 mm²) wire is used, attach AMP 52935 or AMP 52955 crimp-on slotted, number 6, insulated terminals or equivalent.

The actuator end of the wires should be fitted with a number 8 ring terminal, AMP 35108 or equivalent for 12 AWG (3.0 mm²) wire or AMP 32236 or equivalent for 14 AWG (2.0 mm²) wire.

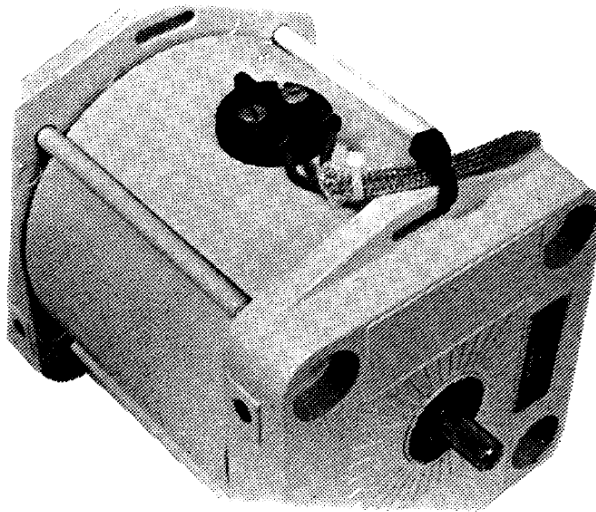

Figure 5. Actuator with Wiring Attached
(Note the tie of the actuator wire to the slot in the side of the actuator.)

8924-826 EPG Mounting Kit Parts List

Part Name.....	Quantity
Washer, 0.265 x 0.500 x 0.032, SS.....	5
Washer, 10 mm.....	2
Washer, 8 mm.....	1
Washer, 0.265 x 0.500 x 0.064, SS.....	2
Washer 0.250 Hi Collar, Lock.....	4
Washer, 0.250 Split Lock.....	5
Screw, M10 x 350 mm.....	2
Screw, M8 x 400 mm.....	1
Screw, 0.250-20 x 0.625 Hex Hd Cap.....	5
Screw, 0.250-28 x .1.250 Hex Hd Cap.....	3
Nut, 0.250-28 Hex Thin, SS.....	2
Nut, 0.250-28 Elastic Hex (thin).....	3
Rod End, Size 4.....	2
Rod, 0.250-28 x 3.750, Threaded.....	1
Lever.....	1
Brace, Mounting Bracket.....	1
Bracket, Mounting.....	1

We appreciate your comments about the content of our publications.

Send comments to: icinfo@woodward.com

Please reference publication **54115**.



PO Box 1519, Fort Collins CO 80522-1519, USA
1000 East Drake Road, Fort Collins CO 80525, USA
Phone +1 (970) 482-5811 • Fax +1 (970) 498-3058

Email and Website—www.woodward.com

**Woodward has company-owned plants, subsidiaries, and branches,
as well as authorized distributors and other authorized service and sales facilities throughout the world.**

Complete address / phone / fax / email information for all locations is available on our website.